

2010

# Investigation of 3-d Heat Transfer Effects in Fenestration Products

Sneh Kumar

*University of Massachusetts Amherst*

Follow this and additional works at: <https://scholarworks.umass.edu/theses>

 Part of the [Heat Transfer, Combustion Commons](#), and the [Other Mechanical Engineering Commons](#)

---

Kumar, Sneh, "Investigation of 3-d Heat Transfer Effects in Fenestration Products" (2010). *Masters Theses 1911 - February 2014*. 519.  
Retrieved from <https://scholarworks.umass.edu/theses/519>

This thesis is brought to you for free and open access by ScholarWorks@UMass Amherst. It has been accepted for inclusion in Masters Theses 1911 - February 2014 by an authorized administrator of ScholarWorks@UMass Amherst. For more information, please contact [scholarworks@library.umass.edu](mailto:scholarworks@library.umass.edu).

**INVESTIGATION OF 3-D HEAT  
TRANSFER EFFECTS IN FENESTRATION  
PRODUCTS**

A Thesis Presented

by

SNEH KUMAR

Submitted to the Graduate School of the  
University of Massachusetts Amherst in partial fulfillment  
of the requirements for the degree of

MASTER OF SCIENCE IN MECHANICAL ENGINEERING

SEPTEMBER 2010

Mechanical and Industrial Engineering

© Copyright by Sneh Kumar 2010  
All Rights Reserved

**INVESTIGATION OF 3-D HEAT  
TRANSFER EFFECTS IN FENESTRATION  
PRODUCTS**

A Thesis Presented

by

SNEH KUMAR

Approved as to style and content by:

---

D. Charlie Curcija, Chair

---

Jon G. McGowan, Member

---

Jonathan P Rothstein, Member

---

Donald Fisher, Department Head

Department of Mechanical and Industrial Engineering

## ACKNOWLEDGMENTS

I would like to sincerely thank my thesis advisor, Dr. D. Charlie Curcija, for his guidance, support, and patience over the progress of this thesis. I am grateful to him for giving me the opportunity to come to University of Massachusetts, Amherst and work under his guidance. His contribution towards my personal and professional development has been immense.

I would also like to thank the members of my thesis advisory committee, Prof. Jon G. McGowan and Prof. Jonathan P Rothstein, for serving on my thesis committee and their support during this work.

I have enjoyed working with my colleagues at Center for Energy Efficiency and Renewable Energy under Building Energy Efficiency Performance (BEEP), Dr. Mahabir Bhandari, Dr. Alexander Fomichov, and Bhaskar Adusumalli.

Finally, I would like to express my gratefulness towards my parents, my sisters, and my wife for their continuous encouragement and support.

## **ABSTRACT**

### **INVESTIGATION OF 3-D HEAT TRANSFER EFFECTS IN FENESTRATION PRODUCTS**

SEPTEMBER 2010

SNEH KUMAR

B. TECH., INDIAN INSTITUTE OF TECHNOLOGY, CHENNAI INDIA

M.S.M.E., UNIVERSITY OF MASSACHUSETTS AMHERST

DIRECTED BY: D. CHARLIE CURCIJA

Buildings in USA<sup>1</sup> consume close to 40% of overall energy used and fenestration products (e.g. windows, doors, glazed-wall etc.) are the largest components of energy loss from buildings. Accurate evaluation of thermal performances of fenestration systems is critical in predicting the overall building energy use, and improving the product performance. Typically, two-dimensional (2-D) heat transfer analysis is used to evaluate their thermal performance as the 3-D analysis is highly complex process requiring significantly more time, effort, and cost compared to 2-D analysis. Another method of evaluation e.g. physical test in a hotbox is not possible for each product as they are too expensive. Heat transfer in fenestration products is a 3-D process and their effects on overall heat transfer need to be investigated. This thesis investigated 3-D heat transfer effects in fenestration systems in comparison to the 2-D results. No significant work has

---

<sup>1</sup> Department of Energy, Energy Information Agency

been done previously in terms of 3-D modeling of windows, which included all the three forms of heat transfer e.g. conduction, convection and radiation.

Detailed 2-D and 3-D results were obtained for broad range of fenestration products in the market with a range of frame materials, spacers, insulated glass units (IGU), and sizes. All 2-D results were obtained with Therm5/Window5 (e.g. currently standard method of evaluating thermal performance) and GAMBIT/FLUENT<sup>2</sup> while all 3-D results were obtained with GAMBIT/FLUENT. All the three modes of heat transfer mechanism were incorporated in the heat transfer modeling.

The study showed that the overall 3-D heat transfer effects are relatively small (less than 3%) for present day framing and glazing systems. Though at individual component level (e.g. sill, head, Jamb) 3-D effects were quite significant (~10%) but they are cancelled by their opposite sign of variation when overall fenestration system effect is calculated. These 3-D heat transfer effects are higher for low conducting or more energy efficient glazing and framing systems and for smaller size products. The spacer systems did not have much impact on the 3-D effects on heat transfer.

As the market transforms towards more insulating and higher performance fenestration products, 3-D effects on heat transfer would be an important factor to consider which it may require correlations to be applied to 2-D models, or may necessitate the development of dedicated 3-D fenestration heat transfer computer programs.

---

<sup>2</sup> GAMBIT is pre-processor software for creating models and FLUENT is a numerical analysis tool using finite volume method.

# TABLE OF CONTENTS

	Page
ACKNOWLEDGMENTS .....	iv
ABSTRACT .....	v
LIST OF TABLES .....	ix
LIST OF FIGURES .....	xii
CHAPTER	
1. INTRODUCTION .....	1
1.1 Background .....	1
1.2 Current Performance Evaluation Options .....	5
1.3 Research Objective .....	9
2. LITERATURE REVIEW .....	11
2.1 Heat transfer in fenestration systems .....	11
2.2 Natural convection in glazing cavities .....	16
2.3 Radiation heat transfer .....	19
2.4 3-D heat transfer modeling of window .....	20
3. MATHEMATICAL AND NUMERICAL MODEL .....	22
3.1 Mathematical model: - .....	22
3.1.1 Convection heat transfer .....	22
3.1.2 Conduction heat transfer: - .....	28
3.1.3 Radiation heat transfer .....	29
3.2 Numerical model: - .....	34
4. PROBLEM DESCRIPTION .....	35
4.1 Description of specimens: .....	35
4.1.1 Wood window: - .....	38
4.1.2 Thermally-Broken (T/B) Aluminum, Aluminum (AL) and PVC windows: .....	39
4.2 Modeling assumptions: - .....	43
4.2.1 Applying Symmetric boundary condition: - .....	43
4.2.2 Modeling of spacer: - .....	46
4.2.3 Modeling of frame cavities: - .....	50
4.2.4 Modeling of conduction models: - .....	51
4.2.5 Material's properties: - .....	52
4.3 Boundary conditions: - .....	53
5. SELECTION OF VISCOUS MODEL FOR GLAZING CAVITY .....	56
5.1 Importance of viscous Model .....	56
5.2 Results of IGU viscous model study .....	59
5.3 Observations and Recommendations on viscous model .....	63
6. RESULTS AND DISCUSSION .....	65
6.1 Obtaining results from THERM5/WINDOW5 .....	65
6.2 Geometry creation in GAMBIT .....	66
6.3 Obtaining results from FLUENT: - .....	70



6.4	Overall result and comparisons: - .....	74
6.4.1	Overall U-factor results and comparisons for CONVECTION models.....	75
6.4.2	Overall U-factor results and comparisons for CONDUCTION models .....	80
6.5	Component level results and comparisons for convection and conduction models .....	88
6.5.1	Component level results and comparisons for wood window (convection models).....	89
6.5.2	Component level results and comparisons for T/B aluminum window (convection models).....	101
6.5.3	Component level results and comparisons for aluminum window (convection models).....	105
6.5.4	Component level results and comparisons for PVC window (convection models).....	109
6.5.5	Component level results and comparisons for wood window (conduction models).....	113
6.5.6	Component level results and comparisons for T/B AL window (conduction models).....	125
6.5.7	Component level results and comparisons for AL window (conduction models) .....	137
6.5.8	Component level results and comparisons for PVC window (conduction models).....	149
6.6	Result comparison for conduction and convection models: - .....	161
6.7	Observations and Discussion: - .....	163
7.	CONCLUSIONS AND RECOMMENDATIONS .....	166
APPENDICES		
A.	MESH DETAILS .....	168
B.	RESULT IMAGE SAMPLES.....	169
BIBLIOGRAPHY .....		176

## LIST OF TABLES

Table	Page
Table 4.1-1: List of fenestration systems analyzed.....	35
Table 4.1-2: Matrix of windows modeled with various glazing and spacer options: .....	36
Table 4.1-3: Comparison of U-Factors between TRR01 and T/B Al.....	40
Table 4.1-4: Comparison for two cases of aluminum window:- .....	42
Table 4.2-1: Calculation for spacer $K_{eff}$ .....	47
Table 4.2-2: U-factor comparison for different spacer models with actual spacer (from THERM):-.....	48
Table 4.2-3: U-factor comparison for different spacer models (from FLUENT 2-D for 0.6m x1.5m window):-.....	48
Table 4.2-4: List of spacers used for modeling:- .....	50
Table 4.2-5: Conductivity and emissivity of the materials used for modeling: - .....	52
Table 4.2-6: Thermo-physical properties of air and argon: -.....	53
Table 4.3-1: Boundary Conditions for various models: - .....	54
Table 5.1-1: Description of the IGU:-.....	58
Table 5.2-1: U-factor and Nusselt number comparison for the IGUs:- .....	60
Table 5.2-2: Heat transfer and Surface Temperature of the IGUs for different Viscous models.....	61
Table 5.2-3: Comparisons of FLUENT 2-D Convection model results with WINDOW5 for various viscous models for Wood window .....	62
Table 6.4-1: Wood window result (convection models).....	75
Table 6.4-2: T/B AL window result (convection models).....	77
Table 6.4-3: Aluminum window result (convection models) .....	78
Table 6.4-4: PVC window result (convection models).....	79
Table 6.4-5: Wood window result (Conduction models).....	80
Table 6.4-6: T/B AL window result (Conduction models).....	82
Table 6.4-7: AL window result (Conduction models) .....	84
Table 6.4-8: PVC window result (Conduction models).....	86
Table 6.5-1: Wood Window – Small Size, Insulating Spacer (convection models).....	89
Table 6.5-2: Wood Window – Small Size, Medium Conducting Spacer (convection models).....	90
Table 6.5-3: Wood Window – Small Size, Highly Conducting Spacer (convection models).....	91
Table 6.5-4: Wood Window – Medium Size, Insulating Spacer (convection models) ....	93
Table 6.5-5: Wood Window – Medium Size, Medium conducting Spacer (convection models).....	94
Table 6.5-6: Wood Window – Medium Size, Highly conducting Spacer (convection models).....	95
Table 6.5-7: Wood Window – Large Size, Insulating Spacer (convection models).....	97
Table 6.5-8: Wood Window – Large Size, Medium Conducting Spacer (convection models).....	98

Table 6.5-9: Wood Window – Large Size, Highly Conducting Spacer (convection models).....	99
Table 6.5-10: T/B Al Window – Small Size, Insulating Spacer (convection models) ...	101
Table 6.5-11: T/B Al Window – Small Size, Medium Conducting Spacer (convection models).....	102
Table 6.5-12: T/B Al Window – Small Size, Highly Conducting Spacer (convection models).....	103
Table 6.5-13: Aluminum Window – Small Size, Insulating Spacer (convection models).....	105
Table 6.5-14: Aluminum Window – Small Size, Medium Conducting Spacer (convection models).....	106
Table 6.5-15: Aluminum Window – Small Size, Highly Conducting Spacer (convection models).....	107
Table 6.5-16: PVC Window – Small Size, Insulating Spacer (convection models).....	109
Table 6.5-17: PVC Window – Small Size, Medium Conducting Spacer (convection models).....	110
Table 6.5-18: PVC Window – Small Size, Highly Conducting Spacer (convection models).....	111
Table 6.5-19: Wood Window - Large Size, Insulating Spacer (Conduction models) ....	113
Table 6.5-20: Wood Window – Large Size, Medium Conducting Spacer (Conduction models).....	114
Table 6.5-21: Wood Window – Large Size, Highly Conducting Spacer.....	115
Table 6.5-22: Wood Window – Medium Size, Insulating Spacer (conduction model)..	117
Table 6.5-23: Wood Window – Medium Size, Medium Conducting Spacer (CONDUCTION MODEL) .....	118
Table 6.5-24: Wood Window – Medium Size, Highly Conducting Spacer (CONDUCTION MODEL) .....	119
Table 6.5-25: Wood Window - Small Size, Insulating Spacer (CONDUCTION MODEL) .....	121
Table 6.5-26: Wood Window – Small Size, Medium Conducting Spacer (CONDUCTION MODEL) .....	122
Table 6.5-27: Wood Window – Small Size, Highly Conducting Spacer (CONDUCTION MODEL).....	123
Table 6.5-28: T/B AL Window – Large Size, Insulating Spacer (Conduction models). 125	
Table 6.5-29: T/B AL Window – Large Size, Medium Conducting Spacer (Conduction models).....	126
Table 6.5-30: T/B AL Window – Large Size, Highly Conducting Spacer (Conduction models).....	127
Table 6.5-31: T/B AL Window – Medium Size, Insulating Spacer (Conduction models).....	129
Table 6.5-32: T/B AL Window – Medium Size, medium conducting Spacer (Conduction models).....	130
Table 6.5-33: T/B AL Window – Medium Size, Highly Conducting Spacer (Conduction Model).....	131
Table 6.5-34: T/B AL Window – Small Size, Insulating Spacer (Conduction Model)..	133

Table 6.5-35: T/B AL Window – Small Size, Medium Conducting Spacer (Conduction Model).....	134
Table 6.5-36: T/B AL Window – Small Size, Highly Conducting Spacer (Conduction Model).....	135
Table 6.5-37: AL Window – Large Size, Insulating Spacer (Conduction Model).....	137
Table 6.5-38: AL Window – Large Size, Medium Conducting Spacer (Conduction Model).....	138
Table 6.5-39: AL Window – Large Size, Highly Conducting Spacer (Conduction Model).....	139
Table 6.5-40: AL Window – Medium Size, Insulating Spacer (Conduction Model).....	141
Table 6.5-41: AL Window – Medium Size, Medium Conducting Spacer (Conduction Model).....	142
Table 6.5-42: AL Window – Medium Size, Highly Conducting Spacer (Conduction Model).....	143
Table 6.5-43: AL Window – Small Size, Insulating Spacer (Conduction Model).....	145
Table 6.5-44: AL Window – Small Size, Medium Conducting Spacer (Conduction Model).....	146
Table 6.5-45: AL Window – Small Size, Highly Conducting Spacer (Conduction Model).....	147
Table 6.5-46: PVC Window – Large Size, Insulating Spacer (Conduction Model).....	149
Table 6.5-47: PVC Window – Large Size, Medium Conducting Spacer (Conduction Model).....	150
Table 6.5-48: PVC Window – Large Size, Highly Conducting Spacer (Conduction Model).....	151
Table 6.5-49: PVC Window – Medium Size, Insulating Spacer (Conduction Model) ..	153
Table 6.5-50: PVC Window – Medium Size, Medium Conducting Spacer (Conduction Model).....	154
Table 6.5-51: PVC Window – Medium Size, Highly Conducting Spacer (Conduction Model).....	155
Table 6.5-52: PVC Window – Small Size, Insulating Spacer (Conduction Model).....	157
Table 6.5-53: PVC Window – Small Size, Medium Conducting Spacer (Conduction Model).....	158
Table 6.5-54: PVC Window – Small Size, Highly Conducting Spacer (Conduction Model).....	159

## LIST OF FIGURES

Figure	Page
Figure 1.1-1: Three main components of a window (left) and Window terminology (right)	3
Figure 1.2-1: Hotbox depiction	5
Figure 1.2-2: Window5/Therm5 calculation overview	8
Figure 2.1-1: Energy flow through the fenestration system (by courtesy of U.S. Department of Energy, Windows and Glazing Research Program)	11
Figure 3.1-1: Angles $\theta$ and $\phi$ Defining the hemispherical solid angle about a Point $P$	32
Figure 4.1-1: Typical Cross-Section of the Wood Window and List of Materials	38
Figure 4.1-2: Sill cross-section views of Wood windows in THERM	39
Figure 4.1-3: Geometry and Cross-Sections of TRR01 Window	40
Figure 4.1-4: Sill cross-section view of TRR01 and T/B-Al windows	41
Figure 4.1-5: Sill cross-section view of aluminum (AL) windows	42
Figure 4.1-6: Sill cross-section view of Al and PVC windows	43
Figure 4.2-1: Geometry, dimensions and vertical plane of symmetry of a window	44
Figure 4.2-2: Sub-divided inside plane of the 3-D model for better resolution of results	45
Figure 4.2-3: sill cross-section in THERM	47
Figure 4.2-4: Spacer details	47
Figure 4.2-5: Single-spacer	48
Figure 4.2-6: Divided spacer	48
Figure 4.2-7: Temperature distribution on inside surface	49
Figure 4.2-8: Frame Cavity effective conductivity from Therm5	51
Figure 4.3-1: Depiction of the boundary conditions for the wood-window	54
Figure 5.1-1: Cross-section view of glazing unit with materials and boundary conditions	57
Figure 5.1-2: Flow regime position for different glazing cavities	59
Figure 5.3-1: Flow regime of IGUs used in the 3-D heat transfer effect investigation	64
Figure 6.1-1: Finite Element Mesh of Sill Cross-Section in THERM of the Wood Window (left) & T/B AL Window (right)	66
Figure 6.2-1: Meshed view of the sill cross-sections of wood-window (Left) and AL/PVC window (Right)	67
Figure 6.2-2: Sill volume of wood-window in 3-D	68
Figure 6.2-3: Different views of the wood-window	69
Figure 6.2-4: Meshed view of window wood (left) and Al/PVC (right) windows	69
Figure 6.3-1: Definition of different flow regimes	71
Figure 6.3-2: Sub-division of 3-D Geometry for Better Resolution of Results	72
Figure 6.3-3: Area of 3-D model (right) used for extracting 2-D* Result (Wood window example)	73
Figure 6.3-4: 2-D Cross-Section From the 3-D Model of the Aluminum and PVC windows	73
Figure 6.4-1: Overall 3-D vs 2-D Differences for Wood Window (convection models)	76

Figure 6.4-2: Overall 3-D vs 2-D Differences for T/B Al Window .....	77
Figure 6.4-3: Overall 3-D vs 2-D Differences for Al Window (convection models).....	78
Figure 6.4-4: Overall 3-D vs 2-D Differences for PVC Window (convection models)...	79
Figure 6.4-5 : 3-D vs 2-D Differences for Wood Window (Conduction models).....	81
Figure 6.4-6: 3-D vs 2-D Differences for T/B AL Window (Conduction models).....	83
Figure 6.4-7: 3-D vs 2-D Differences for AL Window (Conduction models) .....	85
Figure 6.4-8: 3-D vs 2-D Differences for PVC Window (conduction Model).....	87
Figure 6.5-1: Component Level Difference Graphs for Small Size Wood Window (convection models).....	92
Figure 6.5-2: Component Level Difference Graphs for Medium Size Wood Window (convection models).....	96
Figure 6.5-3: Component Level Difference Graphs for Large Size Wood Window (convection models).....	100
Figure 6.5-4: Component Level Difference Graphs for small Size Thermally-broken Aluminum Window (convection models).....	104
Figure 6.5-5: Component Level Difference Graphs for small Size Aluminum Window (convection models).....	108
Figure 6.5-6: Component Level Difference Graphs for small Size PVC Window (convection models).....	112
Figure 6.5-7: Component Level Difference Graphs for Large Size Wood Window .....	116
Figure 6.5-8: Component Level Difference Graphs for Medium Size Wood Window..	120
Figure 6.5-9: Component Level Difference Graphs for Small Size Wood Window (conduction model).....	124
Figure 6.5-10: Component Level Difference Graphs for Large Size T/B AL Window (Conduction Model).....	128
Figure 6.5-11: Component Level Difference Graphs for Medium Size T/B AL Window .....	132
Figure 6.5-12: Component Level Difference Graphs for Small Size T/B AL Window .	136
Figure 6.5-13: Component Level Difference Graphs for Large Size AL Window .....	140
Figure 6.5-14: Component Level Difference Graphs for Medium Size AL Window (Conduction Model).....	144
Figure 6.5-15: Component Level Difference Graphs for Small Size AL Window .....	148
Figure 6.5-16: Component Level Difference Graphs for Large Size PVC Window (Conduction Model).....	152
Figure 6.5-17: Component Level Difference Graphs for Medium Size PVC Window (Conduction Model).....	156
Figure 6.5-18: Component Level Difference Graphs for Small Size PVC Window (Conduction Model).....	160
Figure 6.6-1: Temperature contour for sill and head cross-sections-Convection model	161
Figure 6.6-2: Temperature contour for sill and head cross-sections-Conduction model (FLUENT 2-D, Wood window).....	162
Figure 6.6-3: Temperature plot on inside surface for conduction and convection model .....	163

# CHAPTER 1

## INTRODUCTION

### 1.1 Background

Global warning threats have brought a new found focus on the sources of carbon emissions around the world in recent times. Use of energy from non-renewable sources is directly related to carbon emissions and people have realized the importance of energy conservation. It has led to research and development into new sources of non-conventional and renewable energy. At the same time, making the existing systems more energy efficient has been identified as one of the best ways to conserve energy. In USA, over 39 Quad of energy (~ 40% of all energy used in USA) is used in Building<sup>1</sup> (residential and commercial), making them the largest contributor to the green house gas emission and contributor to global warming. Rest of the energy is used by transportation and industrial sector. In buildings, both commercial and residential, building envelop systems (widnows, wall, roof) play a large role in determing the overall energy performance as they control over 55% of the building enrgy loads. Hence, having accurate thermal performance of fenstration system is critical to building energy design. Other than building energy use and energy load, thermal design of widnow also affects condensation resistance. Accurte performance of fenstration would also spur innovation and improvement in the design of fenestration products.

A fenestration system is a non-opaque aperture in the building envelope. Fenestration systems include conventional windows, roof skylight, sliding doors, and roof monitors etc. The word fenestration comes from Latin word –fenestra, which means

---

<sup>1</sup> Department of Energy, Energy Information Agency 2008

“opening.” They provide passage of air, light, materials, and human being through them. They also provide a connection to outside environment, which has proven to play an important role in our physiological well-being as we spend over 90% of time indoor. Fenestration products provide aesthetic appeal, which designers like as it gives them unique identification through building façade.

There are various performance requirements from Fenestration products with Energy being one of them. Fenestration system designers also need to incorporate Structural, acoustical, and durability performance requirements when designing or selecting these products.

Windows are most commonly identified fenestration products. Fenestration systems consists of three main components as shown in **Figure 1.1-1**: (1) Framing systems; typically the perimeter or mullions or dividers; (2) glazing system made up of layer(s) of glass or plastic with gas filled in between, commonly referred as insulated glass units (IGU); and (3) spacer system which is used to seal the edges of IGUs.



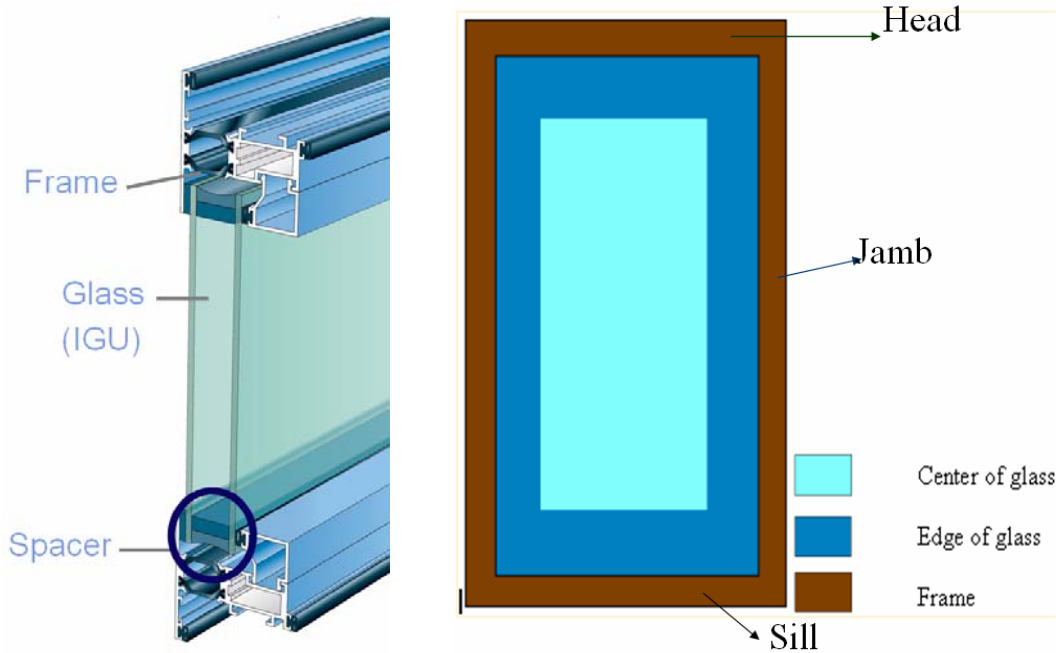

**Figure 1.1-1: Three main components of a window (left) and Window terminology (right)**

Frames are commonly made from wood, aluminum, PVC, or fiberglass. Thermal conductivity and design determine the thermal transmittance of window frame. Since multiple glazing provides better thermal resistance, most glazing manufactured in North America is in the form of insulated glazing units (IGU). IGUs are constructed of multiple panes of glass separated by gas space(s) e.g. air, argon, krypton etc. Spacers are placed between the glass panes to keep them spaced apart along with sealant(s) to keep maintain the gap between panes, and prohibit any moisture-vapor-gas transmission across the seal.

**Figure 1.1-1** above also shows the common terms used to describe various sections of a window e.g. sill, Head, jamb, Edge of glass, center of glass.

Heat transfer through a window take place by following three heat transfer mechanisms: -

- 1) Conduction through the solid components of the window,
- 2) Natural convection on the indoor surface, forced convection on the outdoor surfaces, and laminar/turbulent convection (depending on the condition) in the glazing cavity (or cavities)
- 3) Radiation from the indoor and outdoor surfaces to their respective environments and radiation between the glazing cavity surfaces

Heat gain from solar radiation and heat loss or gains from air infiltration are also factors in fenestration system performance.

The energy performance indices of a fenestration system are: U-factor (sometimes referred to as U- factor), Solar Heat Gain Coefficient (SHGC, the fraction of incident solar radiation admitted through a window, both directly transmitted and absorbed, then subsequently released inward), visible transmittance (VT), and Air Leakage Rating. Thermal performance of the fenestration system, excluding the transmitted solar radiation, is characterized by U-factor, which is the total heat transfer (excluding the solar transmission) for a given set of environmental conditions (boundary condition).

$$Q = U \times A \times (T_i - T_o) \quad (1)$$

U-factor is also referred as thermal transmittance or U-value. It is a standard way to quantify the insulating value of fenestration product or other non-homogenous building envelope component. This value represents a one-dimensional idealization of actual multi-dimensional heat transfer happening through fenestration system. The smaller the U-factor, lower the heat loss (or gain) hence better the window is. U- Factor is the primary determinant of a products thermal rating. Therefore, manufacturers try to

improve their product's rating by minimizing the U- factor to achieve high performance products.

## 1.2 Current Performance Evaluation Options

There are two commonly used methods of determining U-factor 1) Physical test in a hotbox, and 2) computer simulation. U-factors may be determined experimentally in a hot box (guarded or calibrated) from the measured values the surrounding environment (baffles) surface temperatures, the cold box and hot box average air temperatures, and the energy input required to maintain the hot box at constant temperature. Figure 1.2-1 depiction of a hotbox.

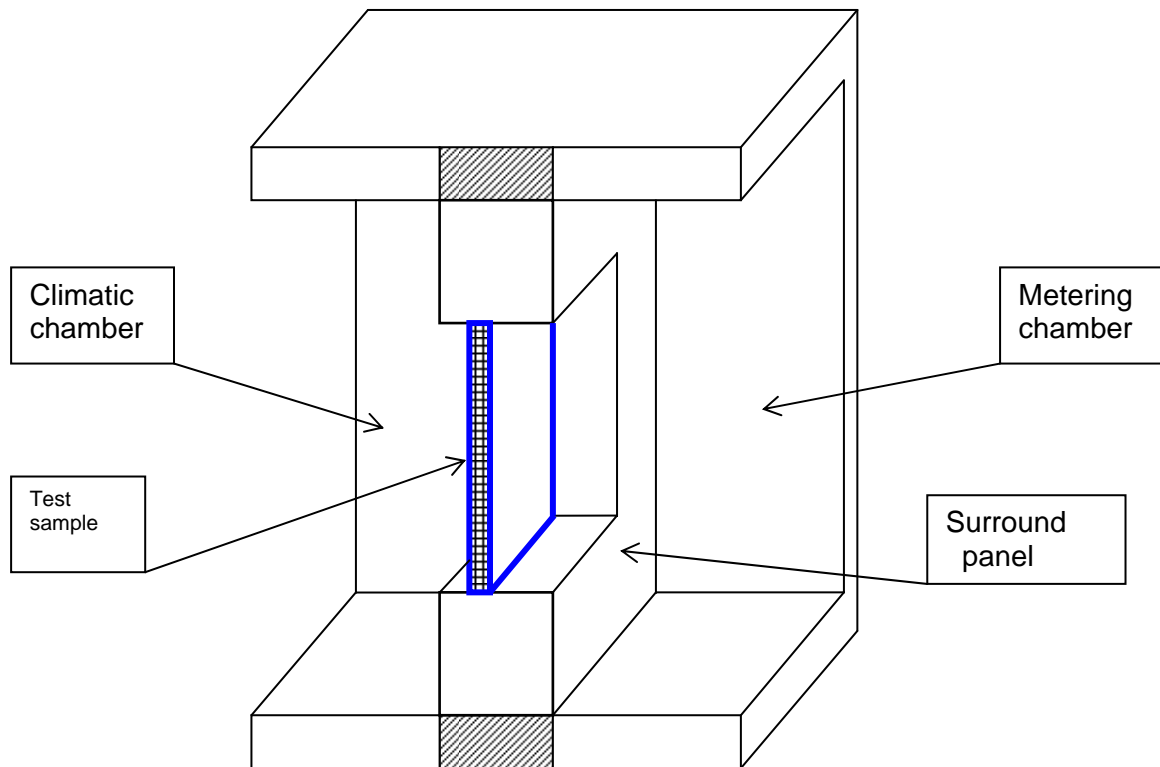

Figure 1.2-1: Hotbox depiction

However, measuring the thermal performance of windows using a hotbox is an expensive proposition. Not only is laboratory testing expensive, but also each window manufacturer typically offers hundreds of individual products, each of which has different thermal performance properties. It will be very expensive for manufacturers to test all the varieties of products.

The other option is getting the U-factor results through computers simulation. Beginning in the 1980s, simulation software began to be used to evaluate the thermal performance of building components including windows, walls, and doors. The advantage with software is that, it not only offers a less expensive means than testing to evaluate window performance, it can also be used during the design process to help manufacturers produce windows that will meet target specifications. However, the big question is how close and reliable are these simulation results to the actual window performance.

In the 1980s, a computer program WINDOW (LBNL 1984) was developed to evaluate the thermal performance of window systems. This program calculates thermal performance properties such as U-factor, shading coefficients, solar heat gain coefficients, and various center-of-glass optical properties. The current version of the program uses a one-dimensional algorithm to evaluate heat transfer through glazing system, which is consistent with the National Fenestration Rating Council (NFRC) rating procedure. The center of glass U- factor,  $U_{cg}$ , is calculated using the definition of the center of glass overall thermal resistance,  $R_{cg}$ :

$$U_{cg} = \frac{1}{R_{cg}} \quad (2)$$

$$R_{cg} = \frac{1}{h_0} + \sum_{j=1}^n \frac{d_j}{k_j} + \sum_{j=1}^{n-1} \frac{1}{h_{gj}} + \frac{1}{h_i}$$

The surface heat transfer coefficients,  $h_i$  and  $h_o$ , are the result of the combined radiation/convection heat transfer on the indoor and outdoor fenestration surfaces. The heat transfer coefficient for the gap space(s) within the glazing cavity,  $h_{gj}$ , is determined from the convective and radiative heat transfer processes that occur in parallel.

WINDOW5 program could be used to analyze products made from any combination of glazing layers, gas layers, frames, spacers, and dividers under any environmental conditions and at any tilt by calculating total product area-weighted properties. As input, it requires information on the optical performance properties of the glazing materials and the results of a detailed two-dimensional heat transfer model on the window's frame and edge thermal performance. The edge of glass area is currently defined as the region of IGU that extends 2.5 inches (0.0635 m) from the frame/glazing interface. This heat transfer information can be generated using THERM (LBNL 1994), a two-dimensional, finite element analysis PC program.

Upon the calculation of U-factors for the edge of glass and frame, the area-weighted total product value can be calculated using the WINDOW program. This procedure for this are-weighted calculation is:

$$U = \frac{A_{cg} \times U_{cg} + A_{eg} \times U_{eg} + A_f \times U_f}{A_{cg} + A_{eg} + A_f} \quad (3)$$

where  $A_{cg}$ ,  $A_{eg}$  and  $A_f$  are the projected areas of center of glass, edge of glass and frame respectively. While  $U_{cg}$ ,  $U_{eg}$  and  $U_f$  are the U-factor of center of glass, edge of glass and

frame. That is to multiply the component property by the component area, sum these area-weighted component properties, and then divide the area-weighted sum by the total projected area of the product. The operator types (fixed, vertical slider, horizontal slider, and casement) determine which components (heads, jamb, sill and meeting rail) are required to calculate the whole product area-weighted values.

Another software program FRAME (Enermodal Engineering Ltd. 1991), developed in Canada, and performs two-dimensional heat transfer calculations.

At present Window5 and THERM 5 are the established, well supported, and standard tools for evaluating thermal performance of fenestration systems. These programs are also referenced by the U.S. standard (NFRC 100) and Canadian Standards (SCA A440.2 and A453) as the standard method for evaluating the thermal performance of fenestration products. Figure 1.2-2 shows the calculation process overview for Window5 and Therm5 programs.

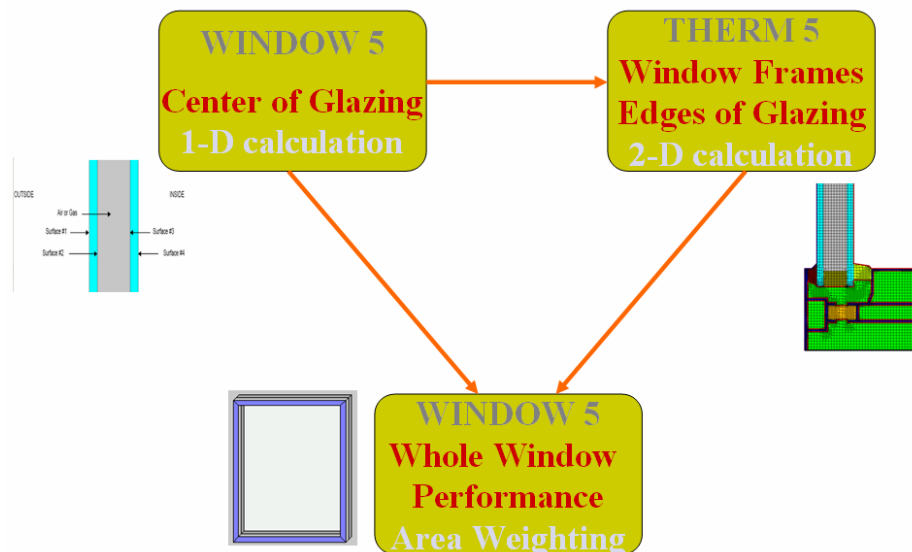

**Figure 1.2-2: Window5/Therm5 calculation overview**

For these prevailing simulation programs, the U-factor of windows is determined with one-dimensional heat transfer calculation for center of glass and a two-dimensional heat transfer calculations for the edge-of-glazing and frame portions.

As shown in Figure 1.2-2, the total U-factor of the product is determined by area weighting the center of glass edge and frame results. Even the corners of window are given the same thermal performance as the center of frame, where the 2-D calculations are obtained. Thus, the complex heat flow through a fenestration system is approximated as an extension of one and two-dimensional heat transfer.

For most building components, which are non-complex, this would be a reasonable assumption. However, windows are much different from walls or insulation products where heat transfer is mostly 1-D or 2-D. For window, three-dimensional effects could be significant and they must be accounted for in order to obtain an accurate value for the total product U-factor. Examples of three-dimensional effects include corners in windows and walls, screws in steel-framed walls, bolts in curtain wall systems, and cross strapping in framed wall systems. Moreover, THERM/WINDOW is conduction-based program and they do not account for the asymmetry in heat flow due to buoyancy driven convection in the glazing cavity. Also for windows, the frame and edge of glass U-factor ( $U_f$  and  $U_{eg}$ ) are actually the results of multidimensional heat transfer taking place in the frame area and in the edge of glass area respectively. Hence, there is need to investigation and estimate extends of 3-D heat transfer effects in fenestration products.

### **1.3 Research Objective**

The objective of this research was to investigate the three-dimensional (3-D) heat transfer effects in the fenestration systems. To achieve the stated objective, detailed 2-D

and 3-D results were obtained for wide range of windows with varying sizes, frame materials (wood, aluminum, thermally broken aluminum, and PVC), spacer systems (high conducting to insulating), and IGU units that represent most of the available window products in the market today.

This investigation focused on finding the 3-D heat transfer effects on the U-factor of the fenestration products only. Other performance indices, like SHGC and VT have negligible or no 3-D effects (in fact, VT has no 2-D or 3-D effects, as all visible portion of solar radiation takes place through IGU without any secondary corner effects), therefore they were not investigated as a part of this research. Condensation resistance performance could be affected due to 3-D heat transfer; however, it was not part of this investigation.

This research project took a systematic approach at the problem, by considering matrix of typical options representing majority of products on the market today and analyzing both 2-D/1-D and full 3-D conduction and convection heat transfer for a wide range of fenestration products. The project investigated and estimated the extend of 3-D heat transfer effects in common fenestration systems along with providing recommendation to handle 3-D heat transfer effects to enhance the accuracy of 1-D and 2-D based thermal performance calculations tools



## CHAPTER 2

### LITERATURE REVIEW

#### 2.1 Heat transfer in fenestration systems

All three modes of heat transfer take place through fenestration systems: Conduction through solid components such as spacer and frame; convection in frame cavities, glazing cavities, and indoor and outdoor surfaces; and radiation heat transfer in any exposed surface. Heat transfer in fenestration system and the accuracy of the whole model largely depends on the solution of the convection part of the problem. Figure 2.1-1 illustrates three major types of energy flow through windows.

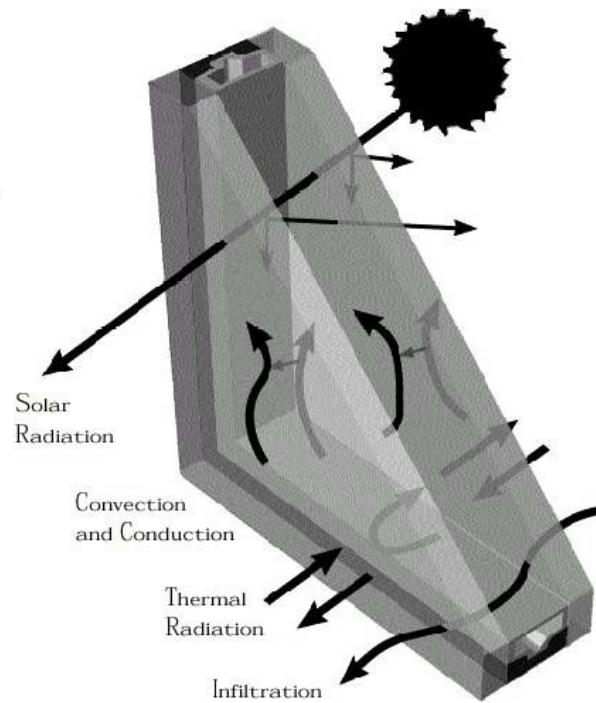

**Figure 2.1-1: Energy flow through the fenestration system (by courtesy of U.S. Department of Energy, Windows and Glazing Research Program)**

Before 1980's, only experimental results were available. By the early 1980's, several researchers (Arasteh (1989), Carpenter and McGowan (1989); EEL (1989), EEL (1990) ;) have tried on numerical solution to these problems. At this stage, the study was restricted to 2-D conduction heat transfer through certain sections of windows.

The main approximation in these studies was the replacement of the air or other gases in the IGU with a solid material whose conductivity is equivalent to the effects of the combined convective and radiative heat transfer added to the value of the conductivity of still gas. This is known as the effective thermal conductivity. Another simplification is the set of boundary conditions, where the approximation was in fact the constant surface heat transfer coefficients on the fenestration boundaries, which were derived from 1-D heat transfer correlations for flat surfaces. The main advantage of this approach is its simplicity, since it replaced a complicated convective, radiative, and conductive heat transfer problem (with four simultaneous nonlinear partial differential equations to solve) with a conduction only heat transfer problem (with a single linear partial differential equation to solve). The main disadvantage of this approach is its inability to predict localized effects. For example, it failed to predict the condition where the convective heat transfer in the IGU creates asymmetric velocity and temperature fields, which, in reality, cause local variations in temperatures and heat flux rates. The effective thermal conductivity approach creates an artificially symmetric temperature field in the edge-of-glass region, therefore limiting the usefulness of the results to predicting overall U-factors that may not fully account for localized effects.

In 1990s, the research has been carried on the convection and radiation heat transfer in the glazing cavities and other cavities of fenestration systems, though most of them are limited to 2-D modeling.

Wright (1990) performed 2-D numerical calculations of laminar convection in a vertical, rectangular slot and 2-D numerical calculation and measurement of laminar heat transfer and radiation in a fenestration system. The combined convective and radiative heat transfer in an IGU cavity and conductive heat transfer in the glazing covered with neoprene pads (in order to duplicate the experimental apparatus setup) were modeled for a range of Raleigh numbers (Ra). Ra is defined as Equation (2.1), which is determined by the temperature difference and the size of the cavity. For some certain window with fixed aspect ratio, the heat flow rate is mainly determined by Ra. In general, under lower Ra the fluid flow within cavity will behave like a laminar flow, while with the increasing of Ra, it is very likely to generate turbulence with higher heat transfer rate.

$$Ra = \frac{\rho\beta\Delta TL^3}{\mu\alpha} \quad (2.1)$$

Smith et al. (1993) used the finite-difference method to model the convective and radiative heat transfer in an IGU cavity and the conductive heat transfer in the glass panes. Rectangular blocks on the top and bottom were used in place of real frame sections, and the conductive and convective heat transfers in these were modeled.

Power (1998) performed several types of numerical calculations on three fenestration systems: PFM01, PFM02, and the IEA (International Energy Agency) glazing unit. These included the idealized one-dimensional conduction by WINDOW 4.1 LBL (1994), 2-D conduction by THERM LBL (1996) where an equivalent overall

thermal conductivity, and 2-D conduction, laminar flow, and turbulent flow using FDI (1996). He performed the laminar and turbulent flow calculations, incorporated gray body radiation between the cavity walls, and used a transient solution. The numerical calculation method for all calculations of fenestration systems utilized a segregated solution procedure. Although the overall comparisons between the numerical calculations of heat transfer through two fenestration products and the measured data were good, there were some differences in the edge of glass regions.

Due to a large computer system requirements and increased computational complexity, 3-D models of heat transfer in windows were prohibitively expensive to run in the past. In some cases, it may be cheaper to test the building component rather than having to perform a 3-D analysis. In any event, some 3-D effects may be small and can be ignored, thereby saving time and money. Since 1990s, some researchers began to study 3-D modeling for windows and their components.

Curcija (1992) is the first researcher to consider 3-D heat transfer through the entire fenestration systems. He performed numerical calculations on the laminar natural convection heat transfer on the indoor fenestration surface and obtained the local heat flux distribution. These results were used as the convective boundary conditions for the indoor surface of a prototype window; laminar forced convection heat transfer on the outdoor fenestration system surface; and using local heat flux results for convective boundary conditions for the prototype window; numerical calculations of 2-D laminar heat transfer, and radiation in a fenestration system for both constant and varying boundary conditions and 3-D calculations for laminar heat transfer and radiation in a fenestration system. One of the important results is the 3-D numerical modeling produced

somewhat higher edge of glass region U-factor ( $U_{eg}$ ), which is due to the end effects of the 3-D glazing cavity. Corrections to 2-D results are recommended in his study. Though it could not describe the window in all of the details at that time, it does provide a good direction for the future work.

Carpenter et al. (1998) studied three complete wall systems with a 3-D finite-difference program (HEAT3, Blomberg 1995). Only conduction heat transfer was considered in this study. Three techniques (parallel path, effective conductivity, and area of influence) are examined that would allow the 2-D program to model 3-D effects. The results from these three techniques were compared with the results from the 3-D model to determine which technique is the most accurate. The “effective conductivity method” in this study is analogous to the area-weighted method. It is easy to apply and provides a conservative estimate of performance. The inaccuracy with this approach in predicting 3-D effects is large when the layers of material have low thermal conductivity. However, on an absolute basis, the 3-D effects are small.

Gustavsen et al. (2001) performed the 3-D conjugate CFD (Computational Fluid Dynamics) simulations of internal window frame cavities. They analyzed the differences between four-sided and single vertical and horizontal frame sections so that to determine the limitations of treating a complete (four-sided) window frames with internal cavities as if it were made up of simple jamb sections. The CFD simulations also seem to indicate that the U-factor of a complete window frame can be found by calculating the average of the horizontal and vertical profile U-factors. Comparing the results from ASHRAE (American Society of Heating, Refrigerating and Air-Conditioning Engineers) and CEN, two correlations in THERM, ASHRAE U-factors compare well with the results of the 3-

D horizontal sections simulated with the CFD program, and CEN U-factors compare well with the results of the vertical 3-D profiles.

## 2.2 Natural convection in glazing cavities

The problem of heat transfer occurred within any cavity in the windows is a classical topic, which usually is addressed as the natural convection in rectangular enclosures. A successful solution to a 3-D cavity flow is the key element in solving the heat transfer problem for windows, thus a brief review for the study on 3-D cavity flow is also made for the matter of complete 3-D analysis in the future.

Convective heat transfer in insulated glazing unit (IGU) cavities is a major component of the overall heat transfer in fenestration systems. Accurately quantifying the heat-transfer coefficient within the cavity is of great significance in calculating the center-of-glass U factor, the edge-of-glass U-factor, and therefore the overall U factor.

There are three dimensionless parameters that affect the cavity flow regimes. These are aspect ratio ( $A$ ),  $Ra$  and Prandtl number ( $Pr$ ). The aspect ratio is the ratio of the cavity height ( $H$ ) to its width ( $W$ ) along the direction with the largest temperature gradient. The Rayleigh number is a function of the fluid properties of the cavity as well as the cavity width and cavity temperature difference (see equation (4)), and the  $Pr$  is a function of the fluid properties of the cavity.

According to previous study on natural convection in 3-D cavities, when the flow becomes 3-D, an additional variable is introduced: the span wise aspect ratio  $H/S$  (where  $S$  is the cavity length in the third dimension), such a system is more complex than its 2-D simplification, but has received less attention. For air fillings, there are a few published works on 3-D natural convection within cavities. For 3-D natural convection in a box, by

the investigation of Fusegi (1991), a few people (Aziz and Hellums (1967), Chorin (1968), Willams (1969), and Mallinson (1973) and de Vahl Davies (1976)) have presented finite difference method for the calculation of internal flows driven by buoyancy forces. Morrison and Tran (1978) describe experiments on a slender ( $H/W = 5$ ) vertical cavity, detailing the effects of sidewall conduction on the flow pattern. Symons and Peck (1984) studied flow and heat transfer with  $H/W = 7.5$  and  $H/W = 45$ . Winters and Brown have undertaken a numerical study of a short cavity ( $H/S = H/W \leq 2$ ). Several studies (Eckert and Carlson 1960; MacGregor and Emery 1969; Yin et al. 1976; Raithby et al. 1977; ElSherbiny et al. 1982; de Vahl Davis 1983; Wright 1990; Curcija 1992) were carried out for cavities with higher aspect ratios typical of fenestration systems. The results are usually reported in the form of an integrated (averaged) Nusselt number or average heat transfer coefficient for the cavity.

Mallinson & Vahl Davis (1973) studied a 3-D window cavity. The window cavity exhibits symmetry about the vertical middle plane. Therefore, solutions were obtained over only one half of the cavity. The average Nusselt number is, in every case (different Ra number), lower than predicted by the 2-D model and within 2.5% of the 2-D estimate. It is concluded that the end effect has a decreasing influence on average Nusselt number ( $Nu$ ) as Ra increases, this can be attributed to the reduction in the thickness of the end-wall boundary layer with increasing Ra. In all cases, the 2-D estimate of the Nu is a better estimate of the vertical average at the center of a 3-D cavity than it is of the overall average.

Reddy (1982) is the first one to consider the solution of the window cavity problem in three dimensions by the finite element method. The natural convection in a

cubical box subjected to differential heating was studied. It was concluded that the fixed wall in the 3-D cavity has the effect of reducing the strength of the flow field. Also, the average  $Nu$  along the vertical wall of the 3-D model is lower than that obtained from 2-D model.

Peutrec et al. (1990) also discussed discrepancies in  $Nu$  at the isothermal walls can be used as an indication of the strength of the side-walls. He found “In the vertical middle plane ( $y=0.5$ ), the flow is almost the one obtained with 2-D simulations. Some changes are seen in the regions adjacent to the isothermal walls, especially for the velocity plots presented for  $y=0.011$ ”. However, it should be noted that the development of 3-D flows produced only by no-slip boundary conditions at the sidewall appears to be weak, in particular at high  $Ra$  numbers. As discussed by Le Peutrec and Lauriat (1987), such weak 3-D effects have little influence on the heat transfer provided that the longitudinal aspect ratio  $A_y$  is greater than one and  $Ra \geq 10^6$ .

Fusegi (1992) studied 3-D natural convection in a cubical enclosure with walls of finite conductance. The main emphasis of this study is placed on scrutinizing changes in the local physical properties of flow and temperature fields due to conducting walls. 3-D variation of heat flow inside the cavity is illustrated by altering the thermal conductance of the horizontal walls and that of the end-walls. He investigated the distribution of the local  $Nu$  at the isothermal vertical walls. As the thermal boundary layer near the heated wall develops from the bottom plate toward the ceiling, the  $Nu$  varies significantly in the vertical direction. However,  $Nu$  is rather uniform in the  $z$ -direction, except for regions close to the end-walls located at  $z=0$  and  $z=1$ .



Experimentally, the challenges in realizing boundary conditions even for a simple geometry such as a square enclosure provide scope for further research. The literature survey on this class of problem is fairly exhaustive. From an overall view of what has been accomplished experimentally, some noticeable end effects were mentioned; for example, N. Ramesh and S.P. Venkateshan reported an experimental study of laminar natural convection heat transfer in a square enclosure using air as the medium and having differentially heated isothermal vertical walls and adiabatic horizontal walls. MacGregor and Emery conducted experiments on rectangular enclosures of various aspect ratios (10, 20, 40).

Curcija (1992) also performed 3-D simulation of natural convection and radiation in glazing cavity. He obtained very similar results to Mallinson and Vahl Davis (1973). As for the window cavity, mainly the cavity within the glasses, which account for a large amount of heat transfer, usually has a very big aspect ratio in two directions. Secondly, the boundary condition of window cavities is undefined, which is subjected to the change of the boundary condition of the entire window, thus creating larger uncertainty in the study.

### **2.3 Radiation heat transfer**

Radiation heat transfer is an important part of the overall heat transfer in a fenestration product. In fenestration products, radiation heat transfer takes place at the exterior surfaces (where natural convection takes place), in the glazing cavities and in frame cavities. The latest version on THERM5.2 has incorporated the detailed radiation modeling, which accurately models 2-D radiation heat transfer based on view factor

instead of traditional black body assumption. The difference between results using a traditional black body assumption and the detailed radiation model can be as high as 30%.

THERM uses a radiation-view-factor algorithm, VIEWER, which is a derivative of the public domain computer program FACET (Shapiro, 1983). This feature enhances the programs accuracy by modeling element-to-element radiation heat transfer directly. This is particularly significant for products with self-viewing surfaces at temperatures that are different from the temperature of the surrounding air. Radiation heat transfer constitutes more than a half of the total surface heat transfer coefficient for surfaces that are subject to natural convection. Significant variations in radiation heat transfer can therefore significantly affect the overall rates of surface heat transfer and correspondingly the overall U-factor of a building envelope component.

For the glazing cavities, WINDOW5 calculations are based on the correlations for determining the heat transfer. In case of frame cavities, for simplicity, they are modeled as solid part and their effective conductivity is used for modeling purpose.

#### **2.4 3-D heat transfer modeling of window**

Some studies done in the past (Curcija and Goss 1995, Svendsen 2000) suggest that 3-D heat transfer effects may not be negligible for fenestration products, but there was no focused effort to determine the level of effect for different types of windows. Curcija and Goss (1995) have used computer models to analyze the 3-D heat transfer of a wood picture window incorporating a double glazed Insulated Glazing Unit (IG). Their results indicate that 3-D heat transfer effects accounted for approximately 3% difference in total U-factor for that particular window. No attempt had been made to develop

universal correction that would account for 3-D effects, because only one type and one size of window was analyzed. For higher conducting frames and for projecting products, this difference could be larger.

## CHAPTER 3

### MATHEMATICAL AND NUMERICAL MODEL

#### 3.1 Mathematical model: -

Heat transfer through fenestration systems can be modeled mathematically by formulation of the governing equations derived from the Conservation of Mass, Newton's Second Law and the First Law of Thermodynamics. The governing equations are written in terms of local velocity components, pressure, and temperature. Equations that govern convection, conduction, and radiation heat transfer, together with the appropriate boundary conditions, constitute a complete mathematical model of heat transfer through fenestration systems.

##### 3.1.1 Convection heat transfer

Convection heat transfer is a non-linear process where the non-linearity arises from the convective fluid motion, which is described by the momentum equation, continuity equation, and the thermal energy transfer by convection heat transfer (conduction plus convective mass motion) is governed by the energy equation. Before making any assumption and simplification, these equations are:

##### Continuity Equation

$$\frac{\partial \rho}{\partial t} + \frac{\partial}{\partial x_j} (\rho u_j) = 0 \quad (3-1)$$

##### Momentum Equation

$$\rho \left( \frac{\partial u_i}{\partial t} + u_j \frac{\partial u_i}{\partial x_j} \right) = \frac{\partial}{\partial x_j} \left( -p \delta_{ij} - \frac{2}{3} \mu \delta_{ij} \frac{\partial u_j}{\partial x_j} + \mu \left( \frac{\partial u_i}{\partial x_j} + \frac{\partial u_j}{\partial x_i} \right) \right) + \rho f_i \quad (3-2)$$

### Energy Equation

$$\rho C_p \left( \frac{\partial T}{\partial t} + u_j \frac{\partial T}{\partial x_j} \right) = \frac{\partial}{\partial x_j} \left( k \frac{\partial T}{\partial x_j} \right) + \beta T \left( \frac{\partial p}{\partial t} + u_j \frac{\partial p}{\partial x_j} \right) + \mu \left( -\frac{1}{\mu} p \frac{\partial u_j}{\partial x_j} - \frac{2}{3} \left( \frac{\partial u_j}{\partial x_j} \right)^2 + \left( \frac{\partial u_i}{\partial x_j} + \frac{\partial u_j}{\partial x_i} \right)^2 \right) + q \quad (3-3)$$

Few assumptions made to simplify our problems are as follows: -

(1) The heat transfer is in steady state, hence all derivatives respect to time reduce to

$$\text{zero, i.e. } \frac{\partial T}{\partial t} = 0;$$

(2) The Boussinesq approximation, which means, the variation of density is only important in the body force term of the governing equations,

(3) An incompressible fluid flow with negligible viscous dissipation,

(4) Constant fluid properties,

(5) The solid portion of fenestration system are made of homogeneous and isotropic material;

(6) The material properties are constant (not temperature dependent);

(7) There are no internal heat sources (i.e.  $q = 0$ ).

(8) For conduction model there is no fluid, all parts are solid. We replace the fill-gas in the glazing cavity with a solid material whose conductivity is equivalent to the combined effects of the convective and radiative heat transfer added to the value of

the conductivity of the still gas. Therefore, all terms in the governing equations respect to velocity and pressure will disappear for conduction model.

Conservation of Mass (Continuity Equation):

$$\frac{\partial u}{\partial x} + \frac{\partial v}{\partial y} + \frac{\partial w}{\partial z} = 0 \quad (3-4)$$

Newton's Second Law (Momentum Equation):

$$\begin{aligned} \rho \left[ u \frac{\partial u}{\partial x} + v \frac{\partial u}{\partial y} + w \frac{\partial u}{\partial z} \right] &= -\frac{\partial P}{\partial x} + \mu \left[ \frac{\partial^2 u}{\partial x^2} + \frac{\partial^2 u}{\partial y^2} + \frac{\partial^2 u}{\partial z^2} \right] \\ \rho \left[ u \frac{\partial v}{\partial x} + v \frac{\partial v}{\partial y} + w \frac{\partial v}{\partial z} \right] &= -\frac{\partial P}{\partial y} + \mu \left[ \frac{\partial^2 v}{\partial x^2} + \frac{\partial^2 v}{\partial y^2} + \frac{\partial^2 v}{\partial z^2} \right] + \rho \beta (T - T_0) g \\ \rho \left[ u \frac{\partial w}{\partial x} + v \frac{\partial w}{\partial y} + w \frac{\partial w}{\partial z} \right] &= -\frac{\partial P}{\partial z} + \mu \left[ \frac{\partial^2 w}{\partial x^2} + \frac{\partial^2 w}{\partial y^2} + \frac{\partial^2 w}{\partial z^2} \right] \end{aligned} \quad (3-5)$$

Conservation of Energy (Energy Equation):

$$\frac{\partial T}{\partial t} + u \frac{\partial T}{\partial x} + v \frac{\partial T}{\partial y} + w \frac{\partial T}{\partial z} = \frac{\lambda}{\rho c_p} \left[ \frac{\partial^2 T}{\partial x^2} + \frac{\partial^2 T}{\partial y^2} + \frac{\partial^2 T}{\partial z^2} \right] \quad (3-6)$$

Where  $\rho$  is the density,  $\mu$  is the dynamic viscosity,  $\beta$  is the thermal expansion coefficient,  $\lambda$  is the thermal conductivity,  $c_p$  is the specific heat and  $T_0$  is reference temperature. The above equation described the laminar governing equation. Flow

### Turbulent Governing Equations

Turbulent flow is a highly complex phenomenon. Fully developed turbulent motion is characterized by entangled eddies of various sizes. Although it is theoretically possible to directly apply the conservation equations (Equation 3-1 to 3-3) to the entire flow field, it is very difficult to do so in practice. To create a feasible numerical model of a turbulent flow field, it is necessary to describe turbulent motion in terms of averaged

quantities. Models that are based on averaged quantities characterize turbulent flows using meshes of reasonable density; therefore, they result in reasonable computational time and costs.

In order to obtain a numerical solution for turbulent flow, Reynolds decomposition is applied to the Navier-Stokes equations, which decomposes the turbulent variables into instantaneous (fluctuating) and mean (time averaged) components, and flow equations are averaged over a time scale that is long enough compared to that of the turbulent motion. There have been numerous numerical methods proposed for the computer simulation of turbulent flow by solving the Reynolds equations.

The standard  $k$ - $\epsilon$  model is a semi-empirical model based on model transport equations for the turbulence kinetic energy ( $k$ ) and its dissipation rate ( $\epsilon$ ). The model transport equation for  $k$  is derived from the exact equation, while the model transport equation for  $\epsilon$  was obtained using physical reasoning and bears little resemblance to its mathematically exact counterpart.

#### Transport Equations for the Standard $k$ - $\epsilon$ Model: -

The turbulence kinetic energy,  $k$  and its rate of dissipation,  $\epsilon$  are obtained from the following transport equations:

$$\frac{\partial}{\partial t}(\rho k) + \frac{\partial}{\partial x_i}(\rho k u_i) = \frac{\partial}{\partial x_j} \left[ \left( \mu + \frac{\mu_t}{\sigma_k} \right) \frac{\partial k}{\partial x_j} \right] + G_k + G_b - \rho \epsilon - Y_M + S_k \quad (3-7)$$

$$\frac{\partial}{\partial t}(\rho \epsilon) + \frac{\partial}{\partial x_i}(\rho \epsilon u_i) = \frac{\partial}{\partial x_j} \left[ \left( \mu + \frac{\mu_t}{\sigma_\epsilon} \right) \frac{\partial \epsilon}{\partial x_j} \right] + C_{1\epsilon} \frac{\epsilon}{k} (G_k + C_{3\epsilon} G_b) - C_{2\epsilon} \rho \frac{\epsilon^2}{k} + S_\epsilon \quad (3-8)$$

In these equations,  $G_k$  represents the generation of turbulence kinetic energy due to the mean velocity gradients, calculated as described in (3-9).  $G_b$  is the generation of

turbulence kinetic energy due to buoyancy, calculated as described in equations 3-13.  $Y_M$  represents the contribution of the fluctuating dilatation in compressible turbulence to the overall dissipation rate. It is neglected for incompressible flow.  $C_{1\epsilon}$ ,  $C_{2\epsilon}$  and  $C_{3\epsilon}$  are constants.  $\sigma_k$  and  $\sigma_\epsilon$  are the turbulent Prandtl numbers for  $k$  and  $\epsilon$ , respectively.  $S_k$  and  $S_\epsilon$  are user-defined source terms.

### Modeling Turbulent Production in the $k$ - $\epsilon$ Models

The term  $G_k$ , represents the production of turbulence kinetic energy. From the exact equation for the transport of  $k$ , this term may be defined as

$$G_k = -\overline{\rho u_i' u_j'} \frac{\partial u_j}{\partial x_i} \quad (3-9)$$

To evaluate  $G_k$  in a manner consistent with the Boussinesq hypothesis,

$$G_k = \mu_t S^2 \quad (3-10)$$

Where  $S$  is the modulus of the mean rate-of-strain tensor, defined as

$$S = \sqrt{2S_{ij}S_{ij}} \quad (3-11)$$

### Modeling the Turbulent Viscosity

The turbulent (or eddy) viscosity,  $\mu_t$ , is computed by combining  $k$  and  $\epsilon$  as follows:

$$\mu_t = \rho C_\mu \frac{k^2}{\epsilon} \quad (3-12)$$

Where  $C_\mu$  is a constant.

### Model Constants

The model constants  $C_{1\epsilon}$ ,  $C_{2\epsilon}$ ,  $C_{3\epsilon}$ ,  $\sigma_k$  and  $\sigma_\epsilon$  have the following default values:



$$C_{1\epsilon} = 1.44, C_{2\epsilon} = 1.92, C_{\mu} = 0.09, \sigma_k = 1.0, \sigma_\epsilon = 1.3$$

These default values have been determined from experiments with air and water for fundamental turbulent shear flows including homogeneous shear flows and decaying isotropic grid turbulence. They have been found to work fairly well for a wide range of wall-bounded and free shear flows.

#### Effects of Buoyancy on Turbulence in the $k$ - $\epsilon$ Models

When a non-zero gravity field and temperature gradient are present simultaneously, the  $k$ - $\epsilon$  models in **FLUENT** account for the generation of  $k$  due to buoyancy ( $G_b$  in Equations 3-7), and the corresponding contribution to the production of  $\epsilon$  in Equations 3-8. The generation of turbulence due to buoyancy is given by

$$G_b = \beta g_i \frac{\mu_t}{Pr_t} \frac{\partial T}{\partial x_i} \quad (3-13)$$

where  $Pr_t$  is the turbulent Prandtl number for energy and  $g_i$  is the component of the gravitational vector in the  $i$ th direction. For the standard  $k$ - $\epsilon$  models, the default value of  $Pr_t$  is 0.85. The coefficient of thermal expansion,  $\beta$ , is defined as

$$\beta = -\frac{1}{\rho} \left( \frac{\partial \rho}{\partial T} \right)_p \quad (3-14)$$

For ideal gases, Equation 3-13 reduces to

$$G_b = -g_i \frac{\mu_t}{\rho Pr_t} \frac{\partial \rho}{\partial x_i} \quad (3-15)$$

It can be seen from the transport equations for  $k$  (Equations 3-7) that turbulence kinetic energy tends to be augmented ( $G_b > 0$ ) in unstable stratification. For stable stratification, buoyancy tends to suppress the turbulence ( $G_b < 0$ ). In **FLUENT**, the effects

of buoyancy on the generation of  $k$  are always included when we have both a non-zero gravity field and a non-zero temperature (or density) gradient.

While the buoyancy effects on the generation of  $k$  are relatively well understood, the effect on  $\epsilon$  is less clear. In **FLUENT**, by default, the buoyancy effects on  $\epsilon$  are neglected simply by setting  $G_b$  to zero in the transport equation for  $\epsilon$  (Equation 3-8). However, we have the option of including the buoyancy effects on  $\epsilon$ . In this case, the value of  $G_b$  given by Equation 3-15 is used in the transport equation for  $\epsilon$  (Equation 3-8). The degree to which  $\epsilon$  is affected by the buoyancy is determined by the constant  $C_{3\epsilon}$ . In **FLUENT**,  $C_{3\epsilon}$  is not specified, but is instead calculated according to the following relation:

$$C_{3\epsilon} = \tanh \left| \frac{v}{u} \right| \quad (3-16)$$

where  $v$  is the component of the flow velocity parallel to the gravitational vector and  $u$  is the component of the flow velocity perpendicular to the gravitational vector. In this way,  $C_{3\epsilon}$  will become 1 for buoyant shear layers for which the main flow direction is aligned with the direction of gravity. For buoyant shear layers that are perpendicular to the gravitational vector,  $C_{3\epsilon}$  will become zero.

### 3.1.2 Conduction heat transfer: -

Conduction heat transfer is governed by the modified energy equation where the velocity components are set equal to zero, and therefore the energy equation (21) reduces to:

$$\frac{\partial^2 T}{\partial x^2} + \frac{\partial^2 T}{\partial y^2} + \frac{\partial^2 T}{\partial z^2} = 0 \quad (3-17)$$

with the following assumptions for the problem being considered:

- The solid portion of fenestration system are made of homogeneous and isotropic material,
- The material properties are constant (not temperature dependent),
- There are no internal heat sources in the fenestration system.

Conduction heat transfer in the solid portions of the fenestration system is solved simultaneously with the laminar natural convection in an IGU cavity. Boundary conditions for the conduction problem considered here consist of a prescribed combined convective and radiative heat flux on each of the boundary surfaces:

$$-k_s \frac{\partial T}{\partial x_j} n_j = q_c + q_r \quad (3-18)$$

where:

$$q_c = h_c (T - T_c)$$

$$q_r = \sigma \varepsilon (T^4 - T_r^4)$$

### 3.1.3 Radiation heat transfer

Radiation heat transfer acts simultaneously with convection heat transfer and, for non-absorbing gases, is coupled only to the convection heat transfer through the boundary conditions on the bounding surfaces. When an entire fenestration system is analyzed, radiation effects in the cavity need to be accounted for and will appear as an

additional (in addition to conduction) heat flux term in the energy equation. At this interface, the application of the conservation of energy results in the energy conducted through the glass being equal to the sum of energy conducted into the cavity fluid and the net radiation energy leaving the glass surface. For a glazing cavity, radiation heat transfer will occur at the interface between the cavity gas and the glass (also at the spacer surfaces located at the top and bottom ends of the cavity).

The radiation heat transfer is described using the net radiation method for determining radiation exchange in an enclosure. For an enclosure with N gray and diffuse surfaces, the radiation heat transfer exchange relationship between the radiating boundaries is given by:

$$\sum_{l=1}^N \left[ \frac{\delta_{kl}}{\varepsilon_l} - F_{kl} \frac{1 - \varepsilon_l}{\varepsilon_l} \right] q_{rl} = \sum_{l=1}^N (\delta_{kl} - F_{kl}) \sigma T_l^4 \quad (3-19)$$

This is a simplified relationship and has the following assumptions associated with it: all surfaces are diffuse, all surfaces have a constant temperature, all surfaces are gray, the air in the cavity is non-participating (i.e., transparent to thermal radiation), and the emissivity of the surfaces are constant.

#### The Discrete Transfer Radiation Model (DTRM)

For radiation modeling in FLUENT, there are several techniques available. Discrete transfer radiation model (DTRM) model is best suited for this problem. The main assumption of the DTRM model is that a single ray can approximate the radiation leaving the surface element in a certain range of solid angles. The equation for the change of radiant intensity,  $dI$ , along a path,  $ds$ , can be written as

$$\frac{dI}{ds} + aI = \frac{a\sigma T^4}{\pi} \quad 3-20$$

where  $\alpha$  = gas absorption coefficient

$I$  = intensity

$T$  = gas local temperature

$\sigma$  = Stefan-Boltzmann constant ( $5.672 \times 10^{-8} \text{ W/m}^2 \cdot \text{K}^4$ )

Here, the refractive index is assumed to be unity. The DTRM integrates Equation 3-20 along a series of rays emanating from boundary faces. If  $\alpha$  is constant along the ray, then  $I(s)$  can be estimated as

$$I(s) = \frac{\sigma T^4}{\pi} (1 - e^{-\alpha s}) + I_0 e^{-\alpha s} \quad 3-21$$

where  $I_0$  is the radiant intensity at the start of the incremental path, which is determined by the appropriate boundary. The energy source in the fluid due to radiation is then computed by summing the change in intensity along the path of each ray that is traced through the fluid control volume. The "ray tracing" technique used in the DTRM can provide a prediction of radiative heat transfer between surfaces without explicit view-factor calculations. The accuracy of the model is limited mainly by the number of rays traced and the computational grid.

The ray paths are calculated and stored prior to the fluid flow calculation. At each radiating face, rays are fired at discrete values of the polar and azimuthal angles (see Figure 3.1). To cover the radiating hemisphere,  $\theta$  is varied from 0 to  $\pi/2$  and  $\phi$  from 0 to  $2\pi$ . Each ray is then traced to determine the control volumes it intercepts as well as its length within each control volume. This information is then stored in the radiation file, which must be read in before the fluid flow calculations begin.

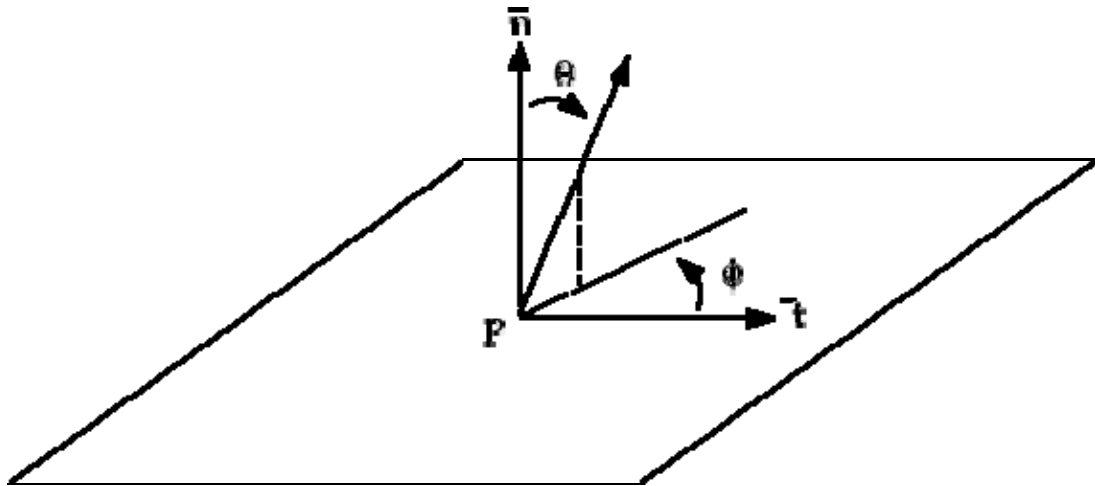

**Figure 3.1-1: Angles  $\theta$  and  $\phi$  Defining the hemispherical solid angle about a Point  $P$**

DTRM is computationally very expensive when there are too many surfaces to trace rays from and too many volumes crossed by the rays. To reduce the computational time, the number of radiating surfaces and absorbing cells is reduced by clustering surfaces and cells into surface and volume "clusters". The volume clusters are formed by starting from a cell and simply adding its neighbors and their neighbors until a specified number of cells per volume cluster is collected. Similarly, surface clusters are made by starting from a face and adding its neighbors and their neighbors until a specified number of faces per surface cluster is collected.

The incident radiation flux,  $q_{in}$ , and the volume sources are calculated for the surface and volume clusters respectively. These values are then distributed to the faces and cells in the clusters to calculate the wall and cell temperatures. Since the radiation source terms are highly non-linear (proportional to the fourth power of temperature), care must be taken to calculate the average temperatures of surface and volume clusters and distribute the flux and source terms appropriately among the faces and cells forming the

clusters. The surface and volume cluster temperatures are obtained by area and volume averaging as shown in the following equations:

$$T_{sc} = \left( \frac{\sum_f A_f T_f^4}{\sum A_f} \right)^{1/4} \quad 3-22$$

$$T_{vc} = \left( \frac{\sum_c V_c T_c^4}{\sum V_c} \right)^{1/4} \quad 3-23$$

where  $T_{sc}$  and  $T_{vc}$  are the temperatures of the surface and volume clusters respectively,  $A_f$  and  $T_f$  are the area and temperature of face  $f$ , and  $V_c$  and  $T_c$  are the volume and temperature of cell  $c$ . The summations are carried over all faces of a surface cluster and all cells of a volume cluster.

Boundary Condition Treatment for the DTRM at Walls: -

The radiation intensity approaching a point on a wall surface is integrated to yield the incident radiative heat flux,  $q_{in}$ , as

$$q_{in} = \int_{\Omega} I_{in} \vec{s} \cdot \vec{n} d\Omega \quad 3-24$$

where  $\Omega$  is the hemispherical solid angle,  $I_{in}$  is the intensity of the incoming ray,  $\vec{s}$  is the ray direction vector, and  $\vec{n}$  is the normal pointing out of the domain. The net radiative heat flux from the surface,  $q_{out}$ , is then computed as a sum of the reflected portion of  $q_{in}$  and the emissive power of the surface:

$$q_{out} = (1 - \epsilon_w) q_{in} + \epsilon_w \sigma T_w^4 \quad 3-25$$

where  $T_w$  is the surface temperature of the point  $P$  on the surface and  $\epsilon_w$  is the wall emissivity which we input as a boundary condition. **FLUENT** incorporates the radiative heat flux (Equation 3-25) in the prediction of the wall surface temperature. This Equation

(3-25) also provides the surface boundary condition for the radiation intensity  $I_o$  of a ray emanating from the point  $P$ , as

$$I_0 = \frac{q_{out}}{\pi} \quad 3-26$$

### 3.2 Numerical model: -

The numerical approximation technique used here to obtain the solutions to the governing equations is Finite Volume method (FVM). In the finite volume method, the domain is divided into small volumes and the governing differential equations are integrated over these volumes. Compared with the finite element method, the finite volume method is more efficient computationally. Meanwhile, it is universal and robust than the finite difference method as it poses very low requirement on domain geometry and flow condition. For this reason, the finite volume method is widely preferred as the generic flow solver.

In this thesis work, the finite volume software FLUENT 6.1 was be used for numerical calculations. Specific numerical schemes were applied to different tasks (e.g. numerical discretization).



## CHAPTER 4

### PROBLEM DESCRIPTION

#### 4.1 Description of specimens:

Three major components of a window: Frame, spacer, and IGU along with the size of the window control the thermal performance of a fenestration product. In this investigation, four window specimens have been analyzed:

1. Wood window
2. Thermally broken Aluminum window (T/B AL)
3. Aluminum window (AL)
4. PVC window

These are very generic and represent a majority of the windows in the market today. It was decided that existing NFRC testing round robins and THERM sample windows would make very good choice for this study, as the performance of these systems have been thoroughly investigated and validated against scrutinized test results. Table 4.1-1 lists the products that are considered in this study:

**Table 4.1-1: List of fenestration systems analyzed**

Window Type	Description
Wood	Marvin sample (prototype) fenestration model - PFM
T/B AL	NFRC test round robin 2001 - TRR01
AL	Modified TRR01 (thermal break replaced with Al)
PVC	Modified TRR01 (Al walls replaced with PVC)

Results were obtained for all these types of windows with for three different sizes with three spacer types, and three IGU; all of them representing a range of product performance from high to low performance.

Table 4.1-2 shows the matrix of all the glazing and spacer options used in modeling the various windows for this study. All these windows are 'fixed' type of window as they are the simplest windows for analysis and their sill, head and jamb cross-section geometries are same for a window.

All the glazing options used in this investigation are double glazed insulated glass units (IGU). All these double glazed units have air or argon (95%)/air (5%) as fill gas. These insulated glass units have an overall thickness of  $(4.7+16.5+4.7=)$  25.9mm with 4.7 mm being the thickness of each glass and 16.5mm that of the fill gas space.

**Table 4.1-2: Matrix of windows modeled with various glazing and spacer options:**

Window		Double Clear	Double HC Low-e	Double SC Low-e
Wood	Gas Fill:	Air	Argon*, Air	Argon*, Air
	Spacer:	Al, Steel, Foam	Al, Steel, Foam	Al, Steel, Foam
T/B-AL	Gas Fill:	Air	Argon*, Air	Argon*, Air
	Spacer:	Al, Steel, Foam	Al, Steel, Foam	Al, Steel, Foam
AL	Gas Fill:	Air	Argon*, Air	Argon*, Air
	Spacer:	Al, Steel, Foam	Al, Steel, Foam	Al, Steel, Foam
PVC	Gas Fill:	Air	Argon*, Air	Argon*, Air
	Spacer:	Al, Steel, Foam	Al, Steel, Foam	Al, Steel, Foam

**Note:** \* Argon composition is 5% Air and 95% Argon and it is present in Low-e glazing only

For Conduction models, an additional glazing with R10 equivalent performance option was included for all the window models.

The spacer options selected for this study cover the entire range of available spacers today from the very insulating foam spacer to medium thermal performing steel spacer to highly conducting aluminum spacer.

Glazing options, spacer types and product geometry have been varied in order to provide a matrix of options that represent entire range of performance, typical of today's technology. Systematic analysis of matrix of product options, covering all of existing products allows for the development of recommendations for accounting of 3-D effects in existing computer tools, without the need to run expensive 3-D heat transfer models in everyday practice.

Three windows sizes selected for the modeling are 0.6m x 0.9m; 0.6m x 1.2m; and 0.6m x 1.5m. The actual size of frame cross-section remains same for all the window sizes. The ratio of glass to frame area changes with change in the size. As the frame and glazing performances may vary, typically with change in size U-factor of window also changes.

For all these combinations of window types, sizes, spacers, and IGUs represented in the above matrix, following sets of results were obtained:

1. 2-D results using THERM5/WINDOW5
2. 2-D results using GAMBIT/FLUENT (Conduction Model)
3. 3-D results using GAMBIT/FLUENT (Conduction Model)
4. 2-D results using GAMBIT/FLUENT (Convection Model)
5. 3-D results using GAMBIT/FLUENT (Convection Model)

Convection model means modeling of glazing cavity gap as fluid where as in Conduction model fluid inside the glazing cavity represented by a solid material (see detailed explanation in the section 4.2.4).

#### 4.1.1 Wood window: -

Figure 4.1-1 shows the details of the wood window. The geometry has been simplified for the modeling purpose as these simplifications reduce the number of element in 3-D modeling significantly without changing the thermal performance. Figure 4.1-2 shows the simplified model of the wood –window in THERM.

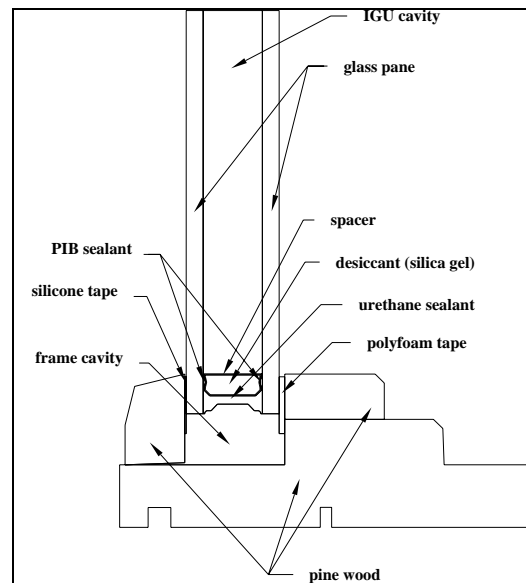

**Figure 4.1-1: Typical Cross-Section of the Wood Window and List of Materials**

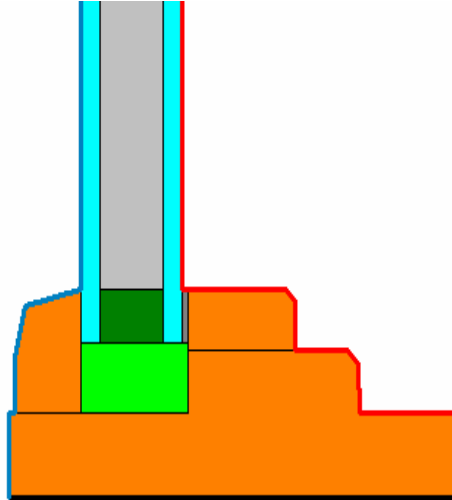

**Figure 4.1-2: Sill cross-section views of Wood windows in THERM**

#### **4.1.2 Thermally-Broken (T/B) Aluminum, Aluminum (AL) and PVC windows:**

T/B, AL, and PVC window models used the same frame cross-section geometry with their frame materials being different in individual window models. The T/B-aluminum window model is based on a NFRC TRR01 (Figure 4.1-3, Figure 4.1-4) - a fixed window type used for NFRC 2001 Round Robin Testing. The T/B-aluminum model (Figure 4.1-4-b) is the simplified model of TRR01.

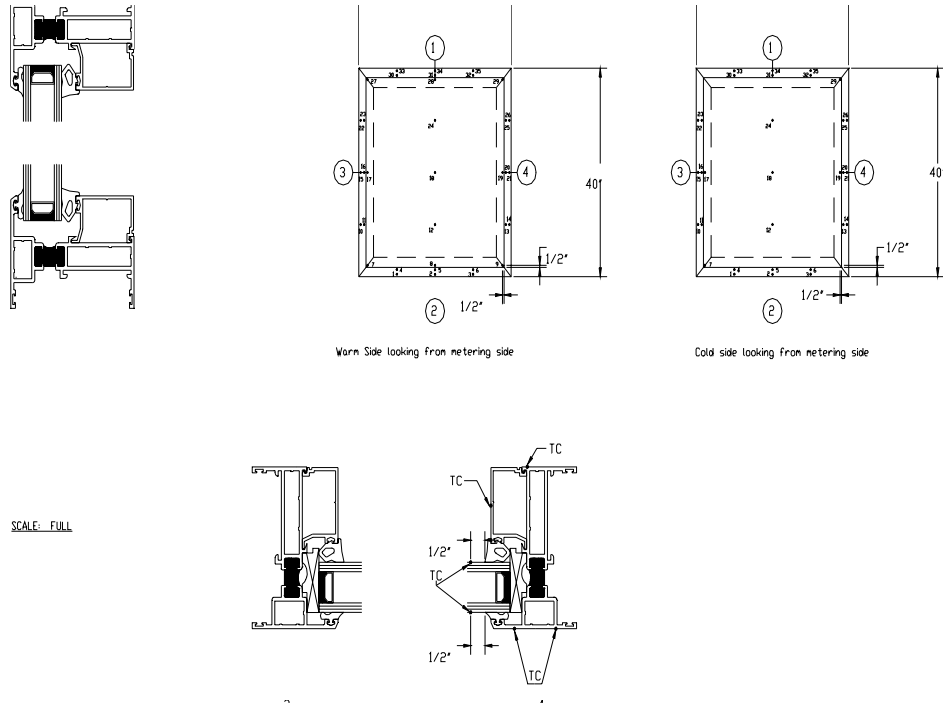
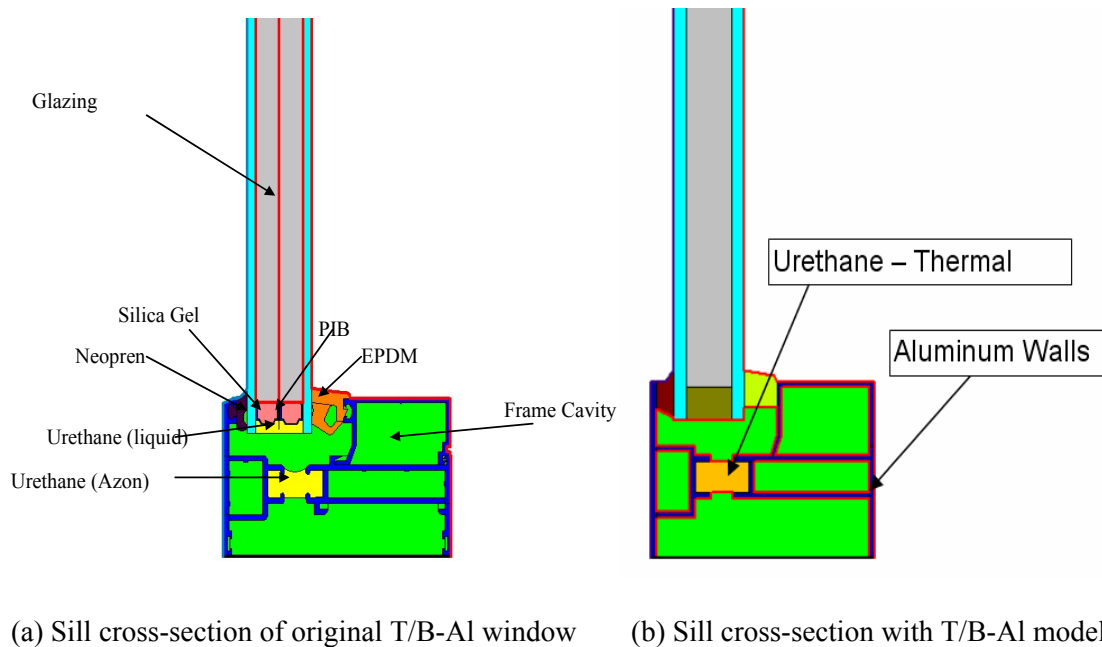

**Figure 4.1-3: Geometry and Cross-Sections of TRR01 Window**

These simplifications reduced the complexity of models by reducing the number of elements in the models without compromising the integrity of results. Table 4.2 shows the comparison between U-factors of TRR01 and the simplified T/B-aluminum window model. This validation was done in THERM5/Window5 to confirm that these simplifications in the geometry did not alter the thermal performance of the window significantly where as they helped immensely by reducing the number of elements in 3-D models.

**Table 4.1-3: Comparison of U-Factors between TRR01 and T/B Al**

	Relative Difference
Edge U-Factor	-0.1%
Frame U-Factor	-2.8%
Whole Window U-Factor	-0.08%



**Figure 4.1-4: Sill cross-section view of TRR01 and T/B-Al windows**

Aluminum window model (Figure 4.1-5) was created from T/B-Aluminum window model by simply replacing the thermal break material (urethane) with Aluminum. Typically aluminum windows are manufactured by replacing the thermal break with the Aluminum extrusion wall (Figure 4.1-5-a). Separate validation in THERM was done to prove that this change was equivalent to replacing the thermal break with the Aluminum extrusion wall.

Table 4.1-3 shows the comparison between the aluminum windows with thermal break filled with aluminum and joined by aluminum walls. This is done as a way to save time in new models generation. The results of these two aluminum window models have been compared in Table 4.1-4. We see that the difference between these two cases is very less. Hence, the aluminum model (Figure 4.1-5-b) was used for modeling AL window, where thermal break material is replaced by aluminum.

**Table 4.1-4: Comparison for two cases of aluminum window:-**

	Relative Difference
Frame U-Factor	1.05%
Edge U-Factor	0.30%
Whole Window U-Factor	0.04%

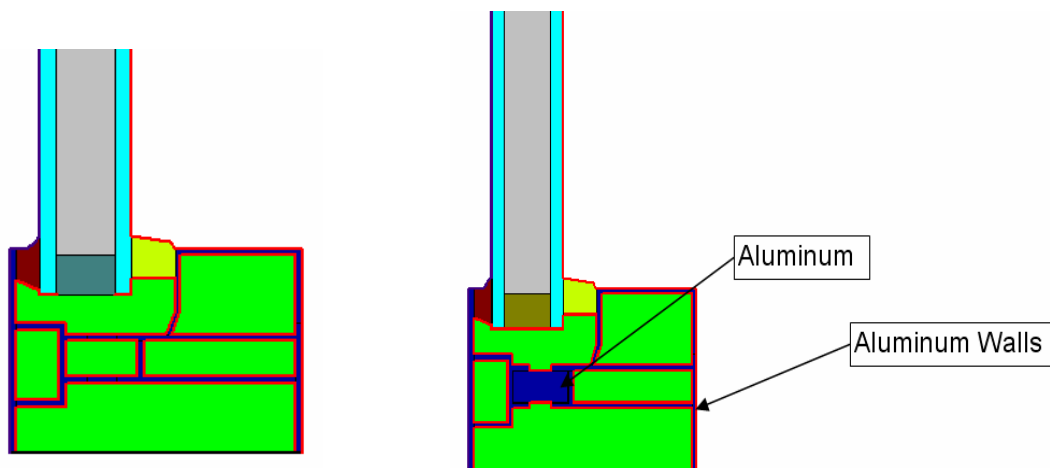

(a) Sill cross-section Typical Al window      (b) Sill cross-section of Al window model

**Figure 4.1-5: Sill cross-section view of aluminum (AL) windows**

PVC window model was created by replacing all the aluminum material in the Al-window model with PVC material (Figure 4.1-6). PVC windows are similar to the aluminum windows in terms of geometry.



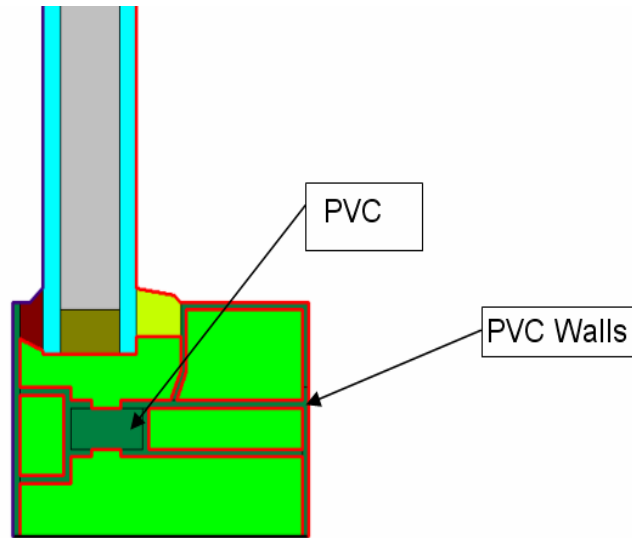
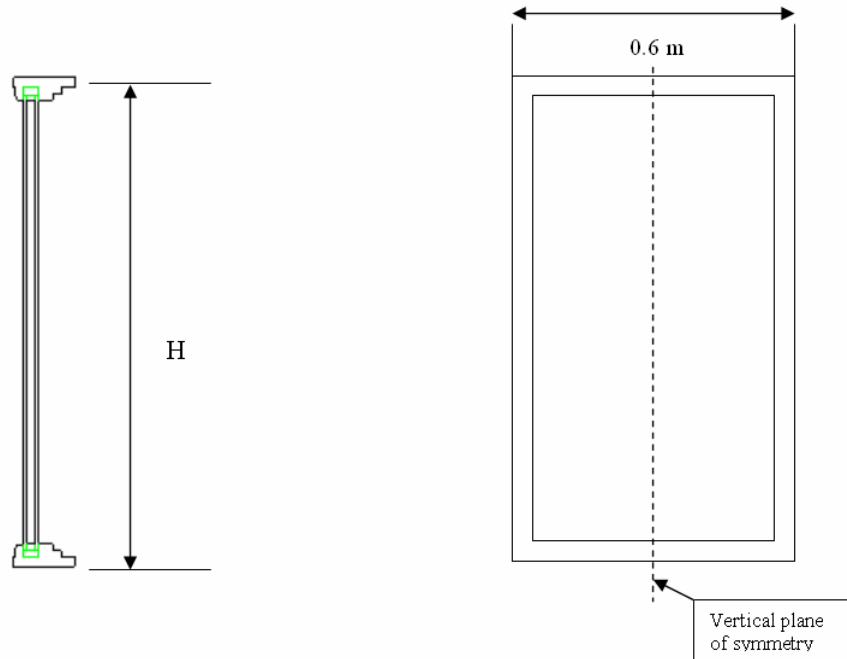

**Figure 4.1-6: Sill cross-section view of Al and PVC windows**

## **4.2 Modeling assumptions: -**

### **4.2.1 Applying Symmetric boundary condition: -**

The geometry of window, boundary conditions, and heat transfer through a window are symmetric about the vertical centerline as shown in the Figure 4.2-1. This allowed us to model only one half of the window about the symmetric plane for 3-D modeling saving a lot of modeling and computational time. Each of window models utilized horizontal symmetry, so only one-half of the window model, divided at the vertical centerline, was modeled. All these models have same sill, head and jamb cross-section, which helped in reducing the modeling time and gives better comparison of results



**Figure 4.2-1: Geometry, dimensions and vertical plane of symmetry of a window**

The inside plane of the 3-D models has been sub-divided into many zones for finding the exact heat transfer from each zone. Figure 4.2-1 shows the vertical plane of symmetry and the 2-D cross-section for the wood window. Figure 4.2-2 shows the inside plane of the wood-window with its subdivided zones. Similar zones on the inside plane will be created for all the 3-D models. The width of all the windows is 0.6m while results will be obtained for three-heights 'H'= 1.5m, 1.2m and 0.91m. It should be noted that the frame cross-section remains same for all sizes of windows.

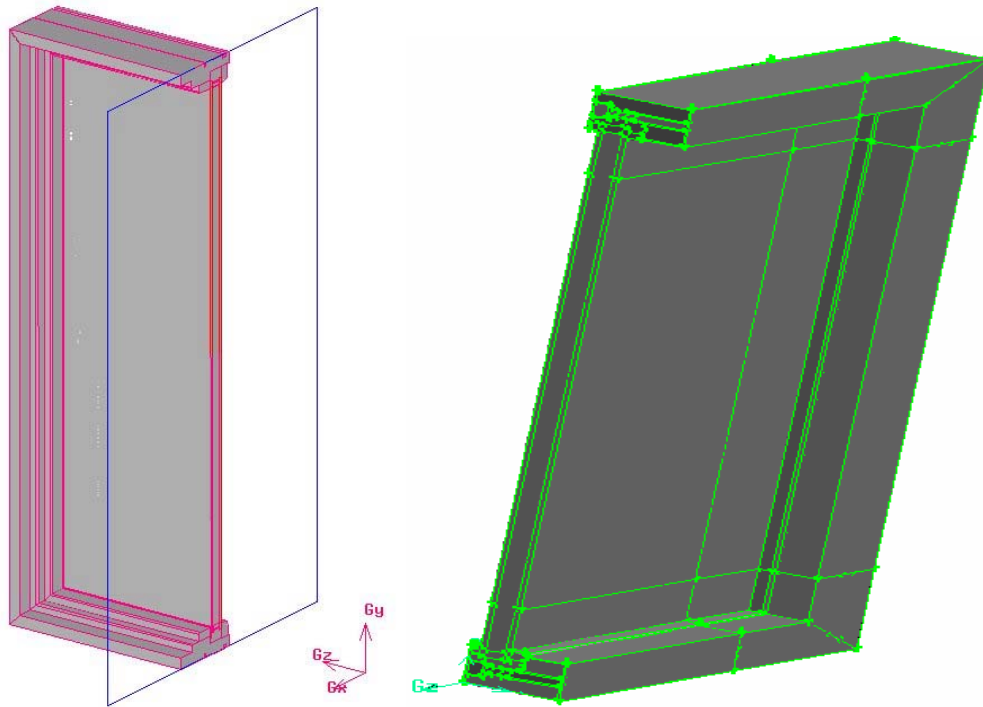
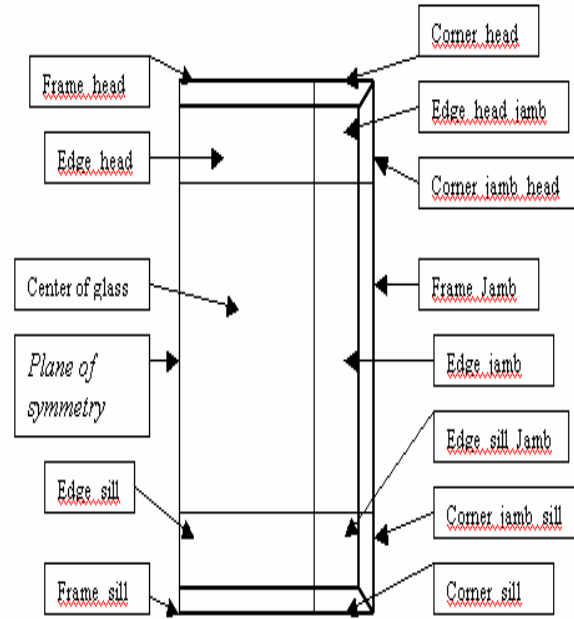

**Figure 4.2-2: Sub-divided inside plane of the 3-D model for better resolution of results**

#### 4.2.2 Modeling of spacer: -

For modeling purpose actual spacer designs were replaced by block of material with same overall size and effective thermal conductivity ( $K_{eff}$ ), calculated from the actual spacer configurations. This modeling simplification was verified through THERM modeling to confirm that it does not create any significant difference in the overall results. It has been proven that this approach produces valid results not only for U-factors but also for condensation resistance results as well. Actual spacer has complicated geometry and it would lead to much higher effort if used in 3-D model. Using a single block of material to replace complex spacer allowed significant simplification in model while preserving the accuracy of results. The use of effective conductivity also allowed changing of spacer for different models by simply changing the effective conductivity of the spacer.

For obtaining the  $K_{eff}$  of a spacer configuration, the results of a frame cross-section (here sill of wood window) was obtained with the actual geometry of spacer design (Figure 4.2-3) in THERM under the specified boundary condition. Separate model with only the spacer part (as shown in Figure 4.2-4) with the temperature obtained from the results of 1st part (Figure 4.2-3 results) as its boundary conditions and use this result to find the effective conductivity of the spacer.

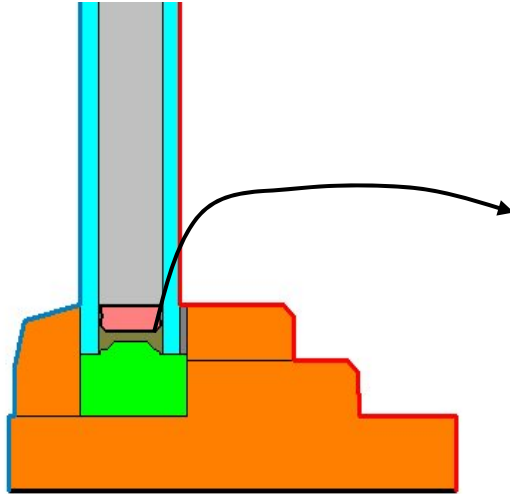

Figure 4.2-3: sill cross-section in THERM

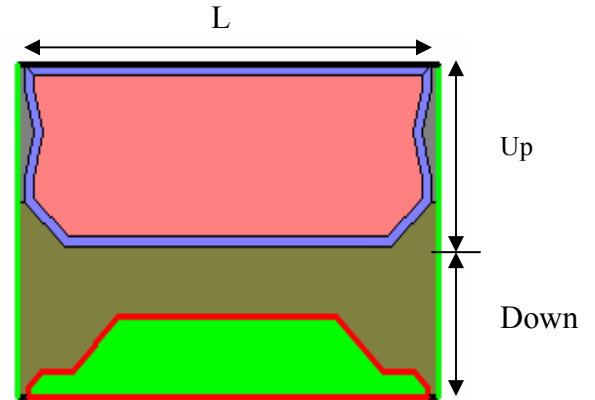

Figure 4.2-4: Spacer details

The current spacer used for showing the modeling for effective conductivity has a frame cavity whose effective conductivity is sensitive to the temperature. A hypothetical, very high film coefficient is applied to keep the surface temperature is close to the actual temperature we got in the 1<sup>st</sup> part. From this result,  $K_{eff}$  is calculated using the following formula.

$$K_{eff} = \frac{L}{\frac{1}{U} - \frac{1}{h_o} - \frac{1}{h_i}} \quad (4.1)$$

Other than obtaining the k-eff for whole spacer, spacer was divided into two parts and k-eff was obtained for each part. Study has done to see what difference it makes to the overall result and temperature profile. It has been discussed later in this section.

Table 4.2-1: Calculation for spacer  $K_{eff}$

$T_{in}$ (°C)	$T_{out}$ (°C)	$h_i$ (W/m <sup>2</sup> °C)	$h_o$ (W/m <sup>2</sup> °C)	L (m)	U-factor (W/m <sup>2</sup> K)	H (m)	$K_{eff}$ (W/m.K)	
0.7	-7.4	99999	99999	0.0165	66.68	6.13	1.1024	up
0.7	-7.4	99999	99999	0.0165	8.91	4.98	0.1472	down
0.7	-7.4	99999	99999	0.0165	40.80	11.11	<b>0.6742</b>	<b>total</b>

Now results were obtained by replacing the spacer with single  $K_{eff}$  and also for divided spacer. Figure 4.2-5 and Figure 4.2-6 show the sill cross-section with replaced spacer, single and divided respectively. Results were also obtained for single and divided spacer in FLUENT. These results are tabulated in Table 4.2-2 and Table 4.2-3.

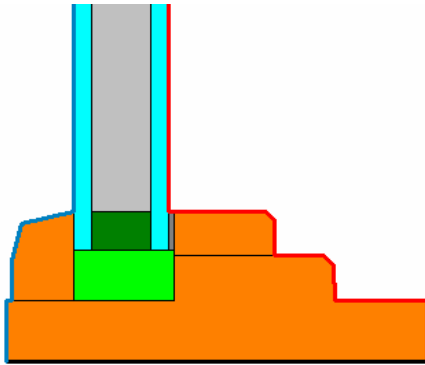

**Figure 4.2-5: Single-spacer**

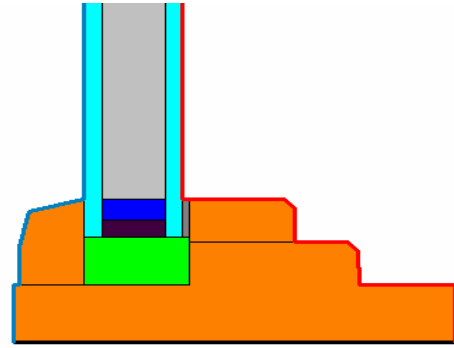

**Figure 4.2-6: Divided spacer**

**Table 4.2-2: U-factor comparison for different spacer models with actual spacer (from THERM):-**

	% diff of single spacer with actual-spacer	% diff of divided-spacer with actual-spacer	% diff of single-spacer with divided-spacer
U-Factor_Frame	0.84%	0.55%	0.29%
U-Factor_Edge	1.2%	0.23%	1.0%

**Table 4.2-3: U-factor comparison for different spacer models (from FLUENT 2-D for 0.6m x1.5m window):-**

Zone	% diff of single-spacer with divided-spacer
<i>Frame_sill</i>	0.83%
<i>Frame_head</i>	0.74%
CoG	-0.02%
<i>Edge_sill</i>	-0.45%
<i>Edge_head</i>	-0.85%

From THERM results, we observe that the difference between the actual spacer and replaced spacer (single or divided) is not significant. It is also shows that there is little difference between the single-spacer and divided-spacer models.

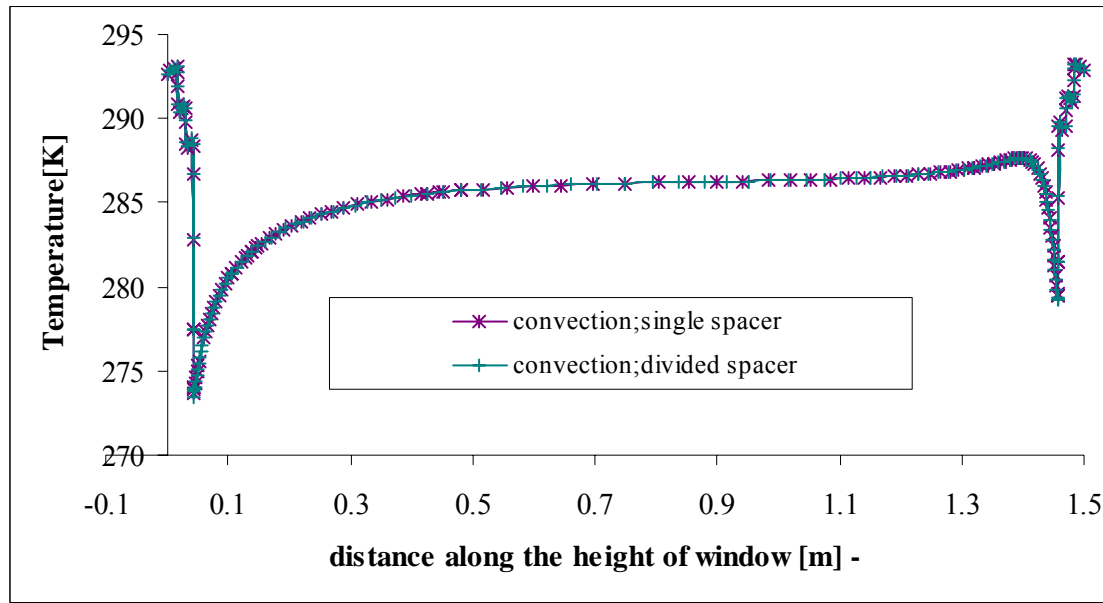

**Figure 4.2-7: Temperature distribution on inside surface**

Looking at the temperature profile on the inside surface (Figure 4.2-7) we see that there is no significant difference between the temperature distribution on the inside surface for these two models of spacers. As the overall difference between the two models is not much, it was decided to go ahead with single replaced spacer model for all the 2-D and 3-D FLUENT models as well as for any models in THERM. Single spacer effective conductivity also defined the thermal characteristic of the spacer performance in just one quantity ( $K_{eff}$ ).

For this study, three types of spacer were used. Table 4.2-4 shows the spacer types with their effective conductivities.

**Table 4.2-4: List of spacers used for modeling:-**

Spacer Type	Characteristic representation	Effective Conductivity ( $K_{eff}$ ) (W/mK)
Foam Spacer	Insulating Spacer	0.0500
Steel Spacer	Medium conducting Spacer	0.6742
Al Spacer	Highly insulating Spacer	1.9000

#### **4.2.3 Modeling of frame cavities: -**

Frame cavities are filled with air. For all the models, frame cavities were modeled as solid to simplify the models without compromising the accuracy of results. Effective-conductivity ( $K_{eff}$ ) of Frame Cavities are used to replicate the equivalent heat transfer through those cavities. The effective conductivity ( $K_{eff}$ ) includes the combined effects of conduction, convection, and radiation heat transfer of the fluid (air) inside the frame cavity. This value is obtained from the simulated results of these frame cross-sections in THERM5 program model. These values from THERMA models were used into all FLUENT 2-d and 3-D models (both convectional and conduction models). THERM does the calculation for  $K_{eff}$  after taking into account of all the three modes of heat transfer - conduction, convection, and radiation. THERM uses ISO-15099 algorithm to calculate the effective conductivity of frame cavities. Replacing these frame cavities with their respective  $K_{eff}$  made sense as it preserved the accuracy of result while reducing the modeling time. Modeling of frame cavity as fluid would have been very time consuming without enhancing the accuracy of the results.



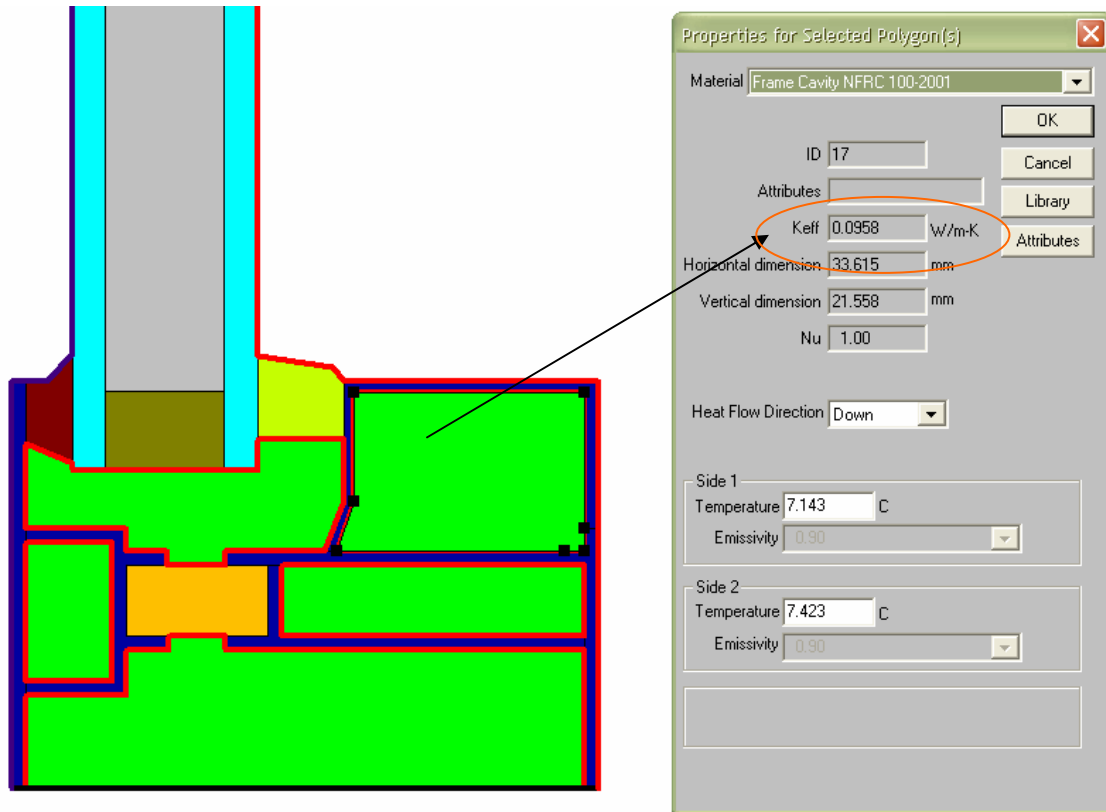

**Figure 4.2-8: Frame Cavity effective conductivity from Therm5**

In the glazing cavity, heat transfer takes place by all the three mechanism e.g. conduction, convection and radiation, in the glazing cavity. Radiation model will also be applied in the glazing cavity.

#### **4.2.4 Modeling of conduction models: -**

Conduction models are defined here as models in which the fluid inside glazing cavity of the insulated glass units is modeled as a solid with an effective thermal conductivity which represents the combined overall heat transfer through conduction, convection and radiation through that glazing cavity. Effective conductivities for glazing cavities were obtained from Window5 program for all the IGUs used for the conduction

models. Window5 calculates the effective conductivity for the cavity based on its heat transfer calculation formulas from ISO 15099. THERM, a conduction model solver, also uses the effective conductivity (from Window5 program) when calculating frame and edge heat transfer.

Conduction models are easier to model and simulate as the fluid dynamics equations do not require to be solved. It becomes a simple conduction and heat transfer equation.

#### 4.2.5 Material's properties: -

All materials are considered homogeneous and isotropic and their properties are constant (not temperature dependent). For solid materials, only conductivity and emissivity properties affect the steady-state heat transfer results. Table 4.2-5 and Table 4.2-6 show the thermal properties of all the materials.

**Table 4.2-5: Conductivity and emissivity of the materials used for modeling: -**

	Material	Conductivity (W/m-K)	Emissivity
1.	Wood	0.14	0.9
2.	Polyfoam Tape	0.24	0.9
3.	Aluminum alloy (painted)	160	0.9
4.	Aluminum alloy ( Mill Finished)	160	0.2
5.	PVC	0.17	0.9
6.	Glass	0.9	$\xi_1=0.84,$ $\xi_2=0.84$
7.	Glass with Hard-coat (HC)	0.9	$\xi_1=0.16,$ $\xi_2=0.84$
8.	Glass with Soft-coat (SC)	0.9	$\xi_1=0.03,$ $\xi_2=0.84$

For density of fluid (air), Boussinesq Model was used. Boussinesq model treats density as a constant value in all solved equations, except for the buoyancy term in the momentum equation.

**Table 4.2-6: Thermo-physical properties of air and argon: -**

<b>Material Property</b>	<b>Air</b>	<b>Argon</b>
Density, $\rho$ [kg/m <sup>3</sup> ]	1.29	1.78
Specific heat, $C_p$ [J/kg-K]	1006.43	521.93
Conductivity, $k$ [W/m-k]	0.0242	0.0163
Viscosity, $\mu$ [kg/m-s]	1.8E-05	2.1E-05
Molecular Weight, [kg/kg-mol]	28.97	39.95
Volume Expansion, $\beta$ [1/K]	0.00364	0.00366

For density of fluid (air), Boussinesq Model was used. Boussinesq model treats density as a constant value in all solved equations, except for the buoyancy term in the momentum equation.

### **4.3 Boundary conditions: -**

Typically, that natural convection occurs on the indoor fenestration surface and within the glazing cavity; and forced convection heat transfer on outdoor fenestration surface. Table 4.3-1 lists the boundary conditions on the inside and outside surfaces. The overall  $h$  value, given in the Table 4.3-1, is the cumulative film heat transfer coefficient, which includes the heat transfer by all the modes (conduction, convection, and radiation) on the outside and inside surface.

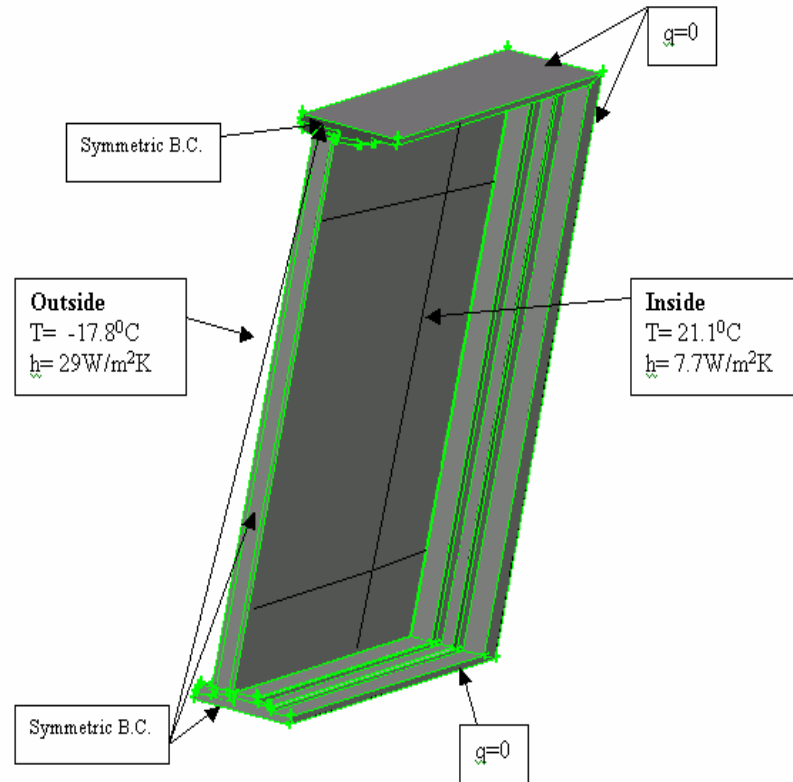

**Figure 4.3-1: Depiction of the boundary conditions for the wood-window**

**Table 4.3-1: Boundary Conditions for various models: -**

Surface	Environmental Temperature [°C] (for all models)	Overall surface heat-transfer coefficient $h$ [W/(m <sup>2</sup> -°K)]	
		Wood windows	T/B-Al/Al/PVC windows
Outside	-17.9	29	29.02
Inside	21.1	7.7	7.9

However, the film heat transfer coefficient depends on the material and its temperature, for modeling simplicity average film heat transfer coefficient has been used. It should be noted that THERM5 incorporates detailed radiation modeling on the inside surface. As discussed in Section 2.3 (radiation heat transfer), the radiation modeling on the inside surface is important for correct heat transfer modeling. Due to complexity

related to radiation modeling on the inside surface and our main objective being focused on finding 3-D effects, we have used the cumulative film heat transfer coefficient. For comparison of FLUENT results with THERM5/WINDOW5 results, identical boundary conditions were applied to all the models.

Top, bottom, and side-end surfaces of the windows are adiabatic ( $q=0$ ) while symmetric boundary condition was applied at the plane of symmetry (see: Figure 4.3-1).

## CHAPTER 5

### SELECTION OF VISCOUS MODEL FOR GLAZING CAVITY

#### 5.1 Importance of viscous Model

In the convection models, correct modeling of the flow inside the glazing cavity is imperative for accurate result of the convection models. This study looks into the differences between various available viscous model solvers in FLUENT and provides guidelines for the best viscous model to use for insulated glass units (IGUs). The nature of the flow inside a glazing cavity depends on its Aspect ratio (height/depth) and the Rayleigh number (Ra) for a given set of boundary conditions. As seen in the plot (Figure 5.1-2), aspect ratio, and Rayleigh number determine whether the flow is laminar or turbulent, and whether it lies in conduction regime or boundary layer regime. It is critical to select the most appropriate viscous model for the best results.

In FLUENT, available viscous models are laminar (for laminar flow) and  $k-\epsilon$  (k-epsilon) &  $k-\omega$  (k-omega) models (for turbulent flow). The results given by these three viscous models differ significantly to affect the results of overall heat transfer. To understand the behavior of these models and to predict the best suitable model for our selected glazing cavities, a study was done on six different types of Insulated glass units. Table 5.1-1 shows the detailed description of these IGUs. 2-D models of IGUs were generated in FLUENT and their solution was compared with Window5 result and existing literature work to evaluate the results from different viscous models of FLUENT.

This study has added significance because the difference between the conduction model and convection model comes from the way IGU is modeled. That is why in this work comparison has been done for wide range of IGUs with the Window5 results. These

IGUs were selected from the sample list of the Window5. Figure 5.1-1 shows the cross-section view with boundary conditions and materials of these IGUs. Exactly same boundary conditions were applied in the Window5 calculations. Height of every glazing unit was taken as 1m as Window5 does its calculations for the standard height of 1m for all the IGUs.

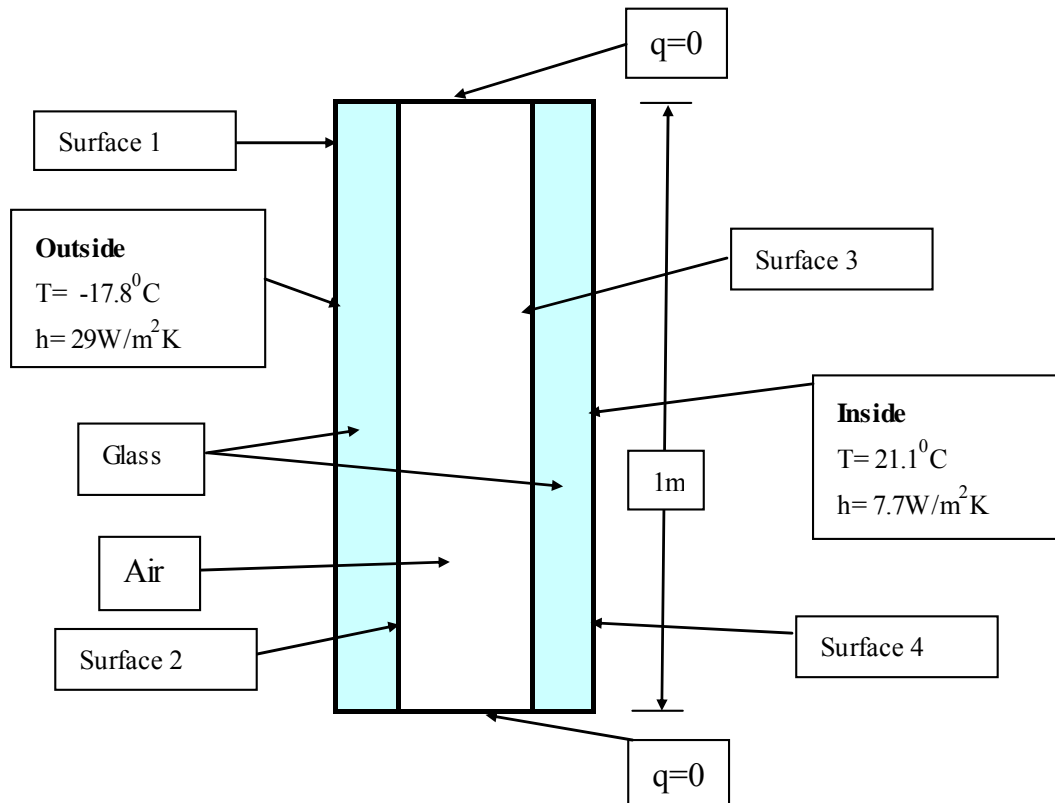
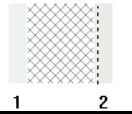
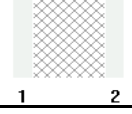
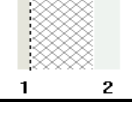
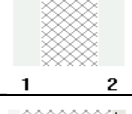
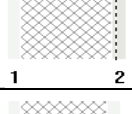



**Figure 5.1-1: Cross-section view of glazing unit with materials and boundary conditions**

The flow inside these glazing cavities lies in the different flow regimes depending on their Aspect ratio and Rayleigh number. Table 5.1-1 shows the Aspect ration and Raleigh number for the six selected IGUs. Figure 5.1-2 shows the flow regime position for all these six glazing cavities. All of them lie close to the border between laminar and turbulent regime. Solutions were obtained with different viscous models for all these

models and compared with Window5 results for U-factor. Other than U-value, Nusselt number calculated from FLUENT result has also been compared with ISO formula (ISO-15099) and formulas obtained by Elsherbiny and Yie.Zhao for comprehensive heat transfer analysis of these viscous models.

**Table 5.1-1: Description of the IGU:-**

ID	Thickness (mm)				Fill Gas	Emissivity on surface				Aspect Ratio (H/d)	Rayleigh Number (ISO)	Picture*
	Total	Glass 1	Glazing Cavity	Glass 2		1	2	3	4			
I	25.9	4.7	16.5	4.7	Air	0.84	0.84	<b>0.16</b>	0.84	60.6	16,144	
II	25.9	4.7	16.5	4.7	Air	0.84	0.84	0.84	0.84	60.6	13,468	
III	21.6	3.2	12.7	5.7	Air	0.84	<b>0.03</b>	0.84	0.84	78.7	7,895	
IV	23.4	5.7	12.0	5.7	Air	0.84	0.84	0.84	0.84	83.3	4,902	
V	25.4	3.0	19.5	3.0	Air	0.84	0.84	<b>0.04</b>	0.84	51.3	27,866	
VI	25.4	3.0	19.5	3.0	Air	0.84	0.84	0.84	0.84	51.3	21,151	

\*Dotted line indicate low-e surface and numbers (1&2) in the picture indicate Glass numbers



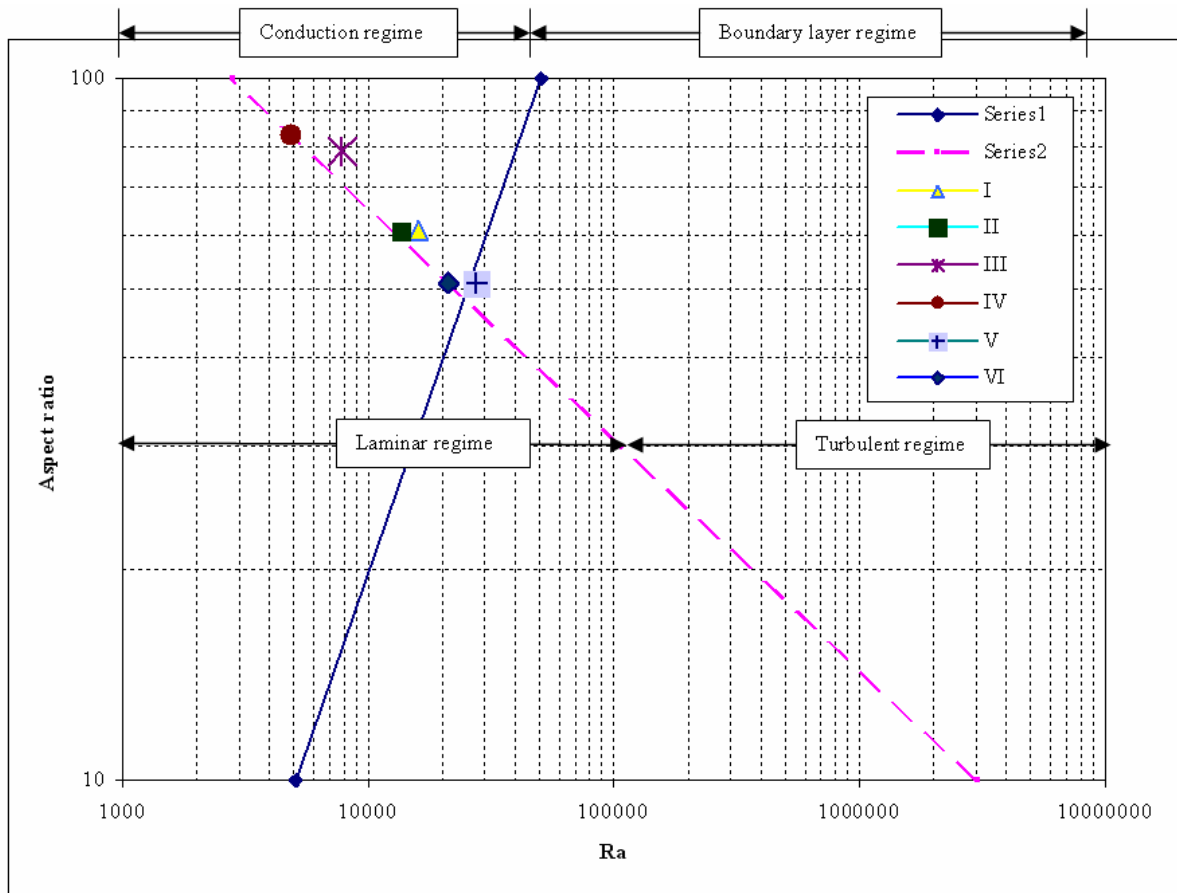

**Figure 5.1-2: Flow regime position for different glazing cavities**

## 5.2 Results of IGU viscous model study

Table 5.2-1 and Table 5.2-2 show the detailed results obtained from FLUENT for these IGUs for various viscous models. Solutions were obtained for laminar,  $k-\epsilon$  and  $k-w$  (standard and SST) viscous models for these IGUs. In some cases, not all of the viscous models could provide a converged solution due to the nature of flow being much different from the type of viscous model being applied to solve them. Table 5.2-1 shows the U-factor result and comparison with the Window5 result. The same table shows the Nusselt number obtained by FLUENT results, from ISO-15099 formulas, Elsherbiny

formulas, and Yie.Zhao. ISO and Elsherbiny's Nusselt numbers are very close as many of Elsherbiny's formulas for Nusselt number calculations are part of ISO- 15099. Table 5.2-2 shows the temperature of all the four surfaces and details of heat transfer in the glazing cavity.

**Table 5.2-1: U-factor and Nusselt number comparison for the IGUs:-**

IGU ID	Viscous Model	Aspect Ratio	Rauleigh Number	U-factor	% diff in U-factor with W5	Nu_Fluent	Nu_ISO	% diff b/w Nu_Fluent and Nu_ISO	Nu_Zhao	Nu_Els.
<b>I</b>	W5	60.6	16,144	<b>1.97</b>	-	-	1.55	-	1.24	1.55
	laminar	60.6	16,846	1.79	-9.4%	1.29	1.57	-17.8%	1.25	1.57
	k-eps	60.6	15,426	2.13	7.9%	1.83	1.52	20.9%	1.23	1.52
	<i>k-w (stand.)</i>	60.6	16,549	1.86	-5.8%	1.40	1.56	-10.7%	1.24	1.56
	<i>k-w (sst)</i>	60.6	16,653	1.83	-7.0%	1.36	1.57	-13.1%	1.25	1.57
<b>II</b>	W5	60.6	13,468	<b>2.77</b>	-	-	1.43	-	1.19	1.44
	laminar	60.6	13,150	2.67	-3.6%	1.22	1.42	-14.2%	1.19	1.43
	k-eps	60.6	12,278	2.88	3.9%	1.76	1.38	27.6%	1.17	1.4
	<i>k-w (stand.)</i>	60.6	13,007	2.70	-2.3%	1.30	1.41	-7.8%	1.19	1.42
	<i>k-w (sst)</i>	60.6	13,076	2.69	-2.9%	1.26	1.42	-10.9%	1.19	1.41
<b>III</b>	W5	78.7	7,895	<b>1.69</b>	-	-	1.16	-	1.07	1.2
	laminar	78.7	7,943	1.66	-1.9%	1.13	1.16	-2.8%	1.07	1.21
	k-eps	78.7	7,482	1.90	12.5%	1.40	1.14	22.5%	1.07	1.18
	<i>k-w (stand.)</i>	78.7	7,939	1.66	-1.8%	1.13	1.16	-2.5%	1.07	1.21
<b>IV</b>	W5	83.3	4,902	<b>2.76</b>	-	-	1.05	-	1.04	1.03
	laminar	83.3	4,877	2.74	-0.4%	1.05	1.05	0.1%	1.04	1.03
	k-eps	83.3	4,714	2.84	3.2%	1.25	1.05	19.2%	1.03	1.01
	<i>k-w (stand.)</i>	51.3	4,877	2.74	-0.4%	1.05	1.05	0.1%	1.04	1.03
<b>V</b>	W5	51.3	27,866	<b>1.82</b>	-	-	1.94	-	1.5	1.94
	k-eps	51.3	27,694	1.85	1.4%	2.02	1.93	4.6%	1.49	1.93
	<i>k-w (stand.)</i>	51.3	29,031	1.65	-9.5%	1.69	1.97	-14.0%	1.52	1.97
<b>VI</b>	W5	51.3	21,151	<b>2.82</b>	-	-	1.73	-	1.38	1.73
	k-eps	51.3	21,031	2.83	0.4%	1.84	1.72	6.7%	1.38	1.73
	<i>k-w (stand.)</i>	60.6	21,711	2.73	3.1%	1.54	1.75	-11.8%	1.39	1.75

Note: Nu\_zhao is the Nusselt number calculated using Yie Zhao's correlation and Nu\_Els is the Nusselt number using Elsherbiny's formulas.

**Table 5.2-2: Heat transfer and Surface Temperature of the IGUs for different Viscous models**

IGU ID #	Viscous Model	Surface Temp.(K)				d (m.)	q_total (W)	q_rad (W)	del_T (T3-T2)
		T1	T2	T3	T4				
<b>I</b>	W5	258.0	258.4	284.0	284.3	0.017	76.7	-	25.6
	laminar	257.7	258.1	284.9	285.2	0.017	69.5	18.8	26.7
	k-eps	258.2	258.6	283.1	283.5	0.017	82.7	17.0	24.4
	<i>k-w (stand.)</i>	257.8	258.2	284.5	284.9	0.017	72.3	18.5	26.3
	<i>k-w (sst)</i>	257.8	258.2	284.6	285.0	0.017	71.3	18.5	26.4
<b>II</b>	W5	259.1	258.6	279.8	280.3	0.017	103.8	-	21.2
	laminar	258.9	259.5	280.2	280.8	0.017	103.8	66.7	20.8
	k-eps	259.2	259.8	279.1	279.7	0.017	111.9	61.9	19.3
	<i>k-w (stand.)</i>	259.0	259.5	280.0	280.6	0.017	105.1	65.9	20.5
	<i>k-w (sst)</i>	259.0	259.5	280.1	280.7	0.017	104.5	66.3	20.6
<b>III</b>	W5	257.7	257.9	285.4	285.8	0.013	65.7	-	27.5
	laminar	257.6	257.8	285.5	285.9	0.013	64.4	4.8	27.7
	k-eps	257.9	258.2	284.2	284.7	0.013	73.9	4.6	26.0
	<i>k-w (stand.)</i>	257.6	257.8	285.5	285.9	0.013	64.5	4.8	27.7
<b>IV</b>	W5	259.1	259.7	279.8	280.4	0.012	107.2		20.1
	laminar	259.0	259.7	279.7	280.4	0.012	106.8	64.2	20.0
	k-eps	259.2	259.9	279.2	279.9	0.012	110.6	61.9	19.3
	<i>k-w (stand.)</i>	259.0	259.7	279.7	280.4	0.012	106.8	64.2	20.0
<b>V</b>	W5	257.8	258.1	284.9	285.1	0.02	70.8	-	26.8
	k-eps	257.8	258.1	284.7	284.9	0.02	71.8	5.0	26.6
	<i>k-w (stand.)</i>	257.6	257.8	285.7	285.9	0.02	64.0	5.3	28.0
<b>VI</b>	W5	259.2	259.5	279.7	280.0	0.02	109.6	-	20.2
	k-eps	259.2	259.5	279.6	280.0	0.02	110.1	64.2	20.1
	<i>k-w (stand.)</i>	259.0	259.4	280.1	280.5	0.02	106.2	66.5	20.7

**Table 5.2-3: Comparisons of FLUENT 2-D Convection model results with WIDNOW5 for various viscous models for Wood window**

Small ( 0.6m X 0.91m) Wood Window									
Spacer Type	Fill gas	Glazing	U- factor	U- factor		U- factor		U- factor	
			<i>Window5</i>	<i>Lam</i>	<i>% diff.</i>	<i>k-eps</i>	<i>% diff.</i>	<i>k-w</i>	<i>% diff.</i>
Insulating Spacer	Air	Clear-clear	2.57	2.48	-2.6%	2.63	3.7%	2.49	-1.9%
	Air (5%)-Argon (95%)	Clear-low-e HC	1.76	1.64	-6.6%	1.88	7.0%	1.91	8.8%
		Clear-low-e SC	1.56	1.42	-7.6%	1.7	10.3%	1.47	-4.7%
Medium conducting Spacer	Air	Clear-clear	2.75	2.66	-2.6%	2.81	2.7%	2.68	-2.0%
	Air (5%)-Argon (95%)	Clear-low-e HC	1.99	1.87	-6.2%	2.1	4.9%	1.91	-4.5%
		Clear-low-e SC	1.8	1.67	-7.1%	1.93	7.1%	1.71	-4.8%
Highly Conducting Spacer	Air	Clear-clear	2.83	2.73	-2.6%	2.87	2.5%	2.75	-2.0%
	Air (5%)-Argon (95%)	Clear-low-e HC	2.08	1.96	-6.0%	2.17	4.3%	1.99	-4.4%
		Clear-low-e SC	1.9	1.76	-6.8%	2.01	6.4%	1.8	-4.7%
Medium ( 0.6m X 1.2m)									
Spacer cond.	Fill gas	Glazing	U- factor	U- factor		U- factor		U- factor	
			<i>Window5</i>	<i>Lam</i>	<i>% diff.</i>	<i>k-eps</i>	<i>% diff.</i>	<i>k-w</i>	<i>% diff.</i>
Insulating Spacer	Air	Clear-clear	2.57	2.48	-3.4%	2.65	3.4%	2.5	-2.6%
	Air (5%)-Argon (95%)	Clear-low-e HC	1.76	1.6	-9.2%	1.87	6.4%	1.65	-6.0%
		Clear-low-e SC	1.57	1.37	-11.1%	1.68	9.6%	1.43	-6.8%
Medium conducting Spacer	Air	Clear-clear	2.76	2.66	-3.2%	2.9	5.5%	2.79	1.5%
	Air (5%)-Argon (95%)	Clear-low-e HC	1.97	1.82	-8.8%	2.08	4.7%	1.88	-5.4%
		Clear-low-e SC	1.78	1.68	-5.9%	1.91	6.9%	1.66	-6.9%
Highly Conducting Spacer	Air	Clear-clear	2.83	2.73	-3.3%	2.89	2.4%	2.74	-3.0%
	Air (5%)-Argon (95%)	Clear-low-e HC	2.05	2.15	3.4%	2.16	4.2%	1.96	-5.3%
		Clear-low-e SC	1.86	1.68	-10.3%	1.97	5.3%	1.74	-6.9%
Large ( 0.6m X 1.5m) wood wondow									
Spacer cond.	Fill gas	Glazing	U- factor	U- factor		U- factor		U- factor	
			<i>Window5</i>	<i>Lam</i>	<i>% diff.</i>	<i>k-eps</i>	<i>% diff.</i>	<i>k-w</i>	<i>% diff.</i>
Insulating Spacer	Air	Clear-clear	2.6	2.47	-3.9%	2.66	3.5%	2.5	-2.6%
	Air (5%)-Argon (95%)	Clear-low-e HC	1.76	1.56	-10.8%	1.87	6.6%	1.64	-6.4%
		Clear-low-e SC	1.55	1.32	-13.4%	1.68	9.9%	1.42	-7.3%
Medium conducting Spacer	Air	Clear-clear	2.76	2.64	-3.7%	2.82	2.7%	2.67	-2.7%
	Air (5%)-Argon (95%)	Clear-low-e HC	1.96	1.77	-9.7%	2.06	4.9%	1.85	-6.1%
		Clear-low-e SC	1.76	1.55	-11.9%	1.88	7.2%	1.63	-7.0%
Highly Conducting Spacer	Air	Clear-clear	2.83	2.7	-3.7%	2.87	2.5%	2.74	-2.3%
	Air (5%)-Argon (95%)	Clear-low-e HC	2.04	1.87	-8.4%	2.13	4.4%	1.92	-5.9%
		Clear-low-e SC	1.84	1.62	-11.4%	1.95	6.6%	1.71	-6.8%

### 5.3 Observations and Recommendations on viscous model

The analysis of these IGUs shows the general trend of these viscous models. Laminar and  $k-\omega$  models under-predict while  $k-\epsilon$  model over-predicts the heat transfer in a glazing cavity when compared to Window5 and ISO results. It is not easy to formulate a general opinion about which viscous model is best. These results confirm the established theory that Rayleigh number and aspect ratio control the heat transfer in a glazing cavity.

Depending on the Rayleigh number and Aspect ratio, it was observed that laminar solutions are best for low Rayleigh number flows that lie in the laminar regime or on the border of laminar-turbulent flow regime. As we see in the case of IGU units III and IV the laminar solution is very close to the Window5/ISO solutions.

Most complicated solutions were for flows in IGU units I and II with mid-range Rayleigh number (around 15,000). For these flow regimes lying at the boundary of laminar-turbulent regime, flow is neither fully laminar nor fully turbulent. Hence, all the solutions were off from the Window5 and ISO results. For these not-fully-developed-turbulent cases laminar and  $k-\omega$  gave better solution than the  $k-\epsilon$  model.

No converged solution could be obtained for IGU-ID V and VI with laminar model as they lie within the turbulent region and they have very high Rayleigh number. For high Rayleigh number (IGU units V & VI) the  $k-\epsilon$  gives better results than  $k-\omega$  model. The limitation with the  $k-\epsilon$  model is that it does not take into account the turbulence due to buoyancy while  $k-\omega$  model does that. That could be a reason for  $k-\omega$  model under-predicting of all the results compared to  $k-\epsilon$  model. In addition, it is noticed that for glazing units V & VI Nusselt number matches well with the ISO formula.

Another important observation from this study was that there were no effects of low- $\epsilon$  coating on the Nusselt number and on the viscous solution model.

From these results and interpretations, it can be concluded that k-epsilon model gives better results for flow lying in the turbulent region with high Rayleigh number ( $>20,000$ ) and its results are very close to the Window5 results. For the laminar regime flows, 'laminar viscous model' gives better results than other viscous models. Observations from this IGU study were implemented while obtaining results for the 2-D and 3-D convection models of window for this project.

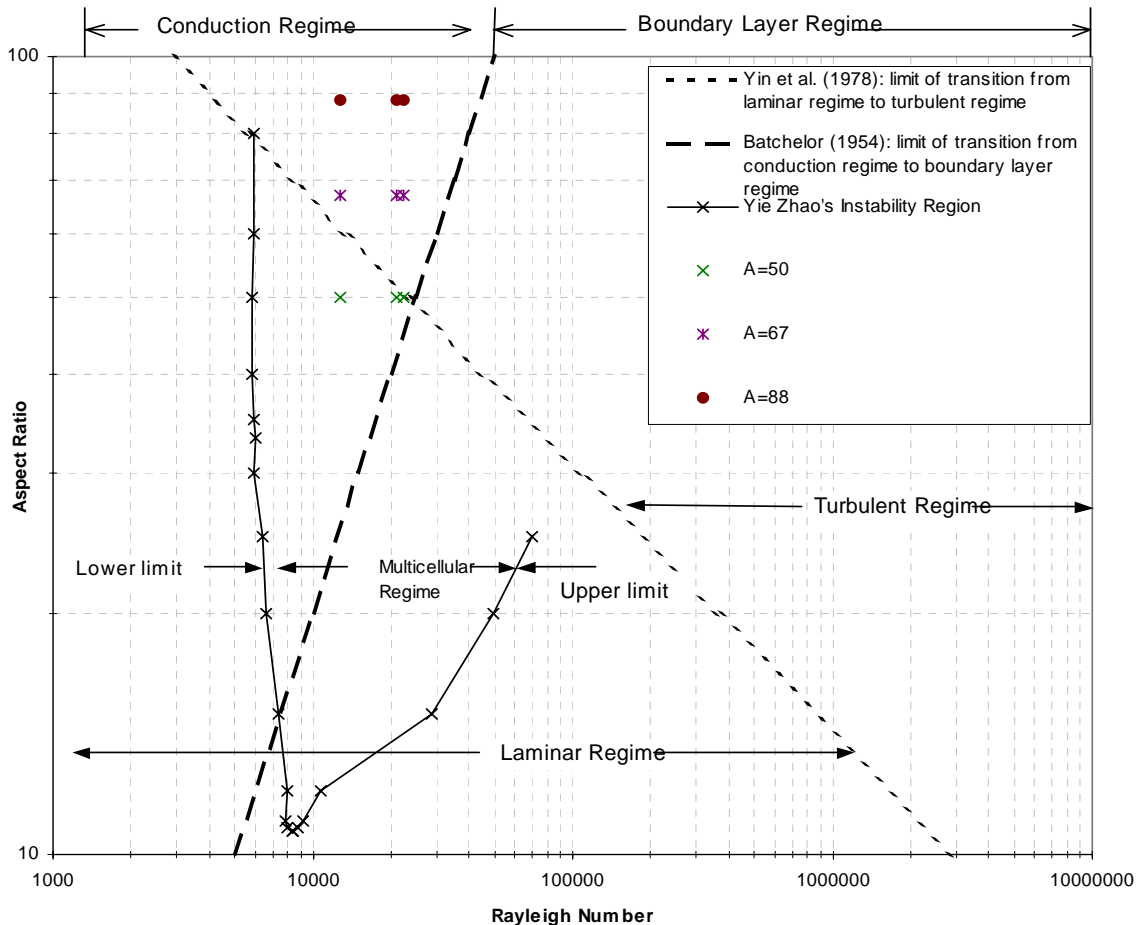

Figure 5.3-1: Flow regime of IGUs used in the 3-D heat transfer effect investigation

## CHAPTER 6

### RESULTS AND DISCUSSION

This Chapter illustrates the process of obtaining result and the discussion on the obtained results. In chapter 4 (Problem Description), the specimens selected for this study, their geometry and applied boundary conditions were discussed. The heat transfer results for all the window models were obtained from THERM/WINDOW (2-D models) and from GAMBIT/FLUENT (2-D and 3-D models). FLUENT models were done in 2-D and 3-D for effective assessment of 3-D effects. GAMBIT is the pre-processor software where the geometry and mesh is created for all the models before exporting to FLUENT. In FLUENT, all the boundary conditions and materials properties are defined prior to obtaining the results. FLUENT 2-D and 3-D model results were compared to analyze the 3-D heat transfer effects. This was done because it is the true ‘apples-to-apples’ comparison that exposes 3-D effects and most effectively eliminates any noise in the results. Other than this 2-D model, results from FLUENT were compared to THERM/WINDOW results to see the difference between the conduction and convection models. GAMBIT/FLUENT results were obtained for conduction and convection models for all 2-D and 3-D models.

#### 6.1 Obtaining results from THERM5/WINDOW5

Thermal results were obtained first from THERM5 and WINDOW5 models for all the window models. THERM (2-D finite element analysis tool) does the heat-transfer calculation for frame and edge parts of a window while WINDOW5 program calculates for the Center-of-glass and overall window performance. Geometry and boundary

conditions were applied as discussed in Chapter 4. THERM program when calculating the Frame and Edge of glass performances uses center of glass performance. These results are imported into WINDOW5 program; where they are used along with the Center of glass performance to calculate the whole product performance.

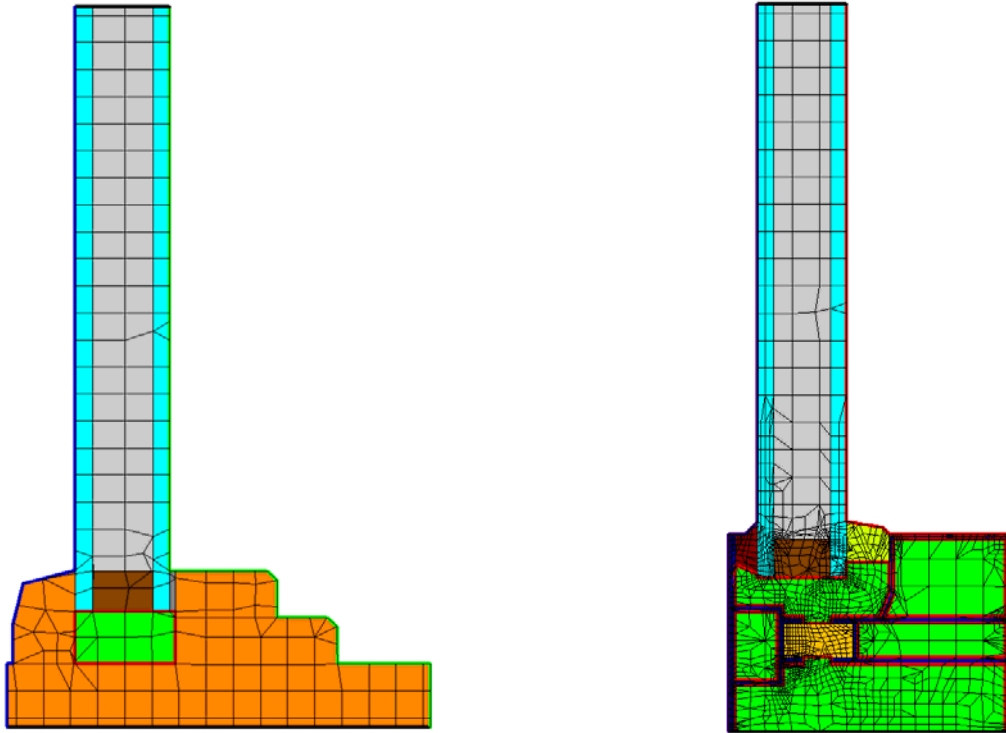

**Figure 6.1-1: Finite Element Mesh of Sill Cross-Section in THERM of the Wood Window (left) & T/B AL Window (right)**

Effective conductivities of frame cavities and glazing cavities, obtained from THERM/WINDOW models, were utilized in FLUENT models.

## 6.2 Geometry creation in GAMBIT

As discussed in Chapter 4, as the geometry of window, boundary conditions and heat transfer through window is symmetric about the vertical plane of symmetry, it



allows us to model only one half of the window about the vertical symmetric plane. It saved lot of modeling and computational time.

To the frame cross-section in AutoCAD command region was applied to convert the closed planar loops into faces. It was exported as ACIS file. This ACIS file of frame cross-section was imported to GAMBIT. This saves a lot of time in drawing the exact frame cross-section in Gambit. It is checked for duplicate entities (face/edge/vertices) before proceeding further.

The acquired 2-D cross-section of sill was be meshed. Head section is created by a mirror copy of meshed sill cross-section. They were joined to create glass and glazing parts. Glazing parts were meshed. Boundary conditions and continuum entities were defined. Now the 2-D model is ready to be exported to FLUENT for solving. Figure 6.2-1 shows the meshed view of the sill cross-section for the wood-window.

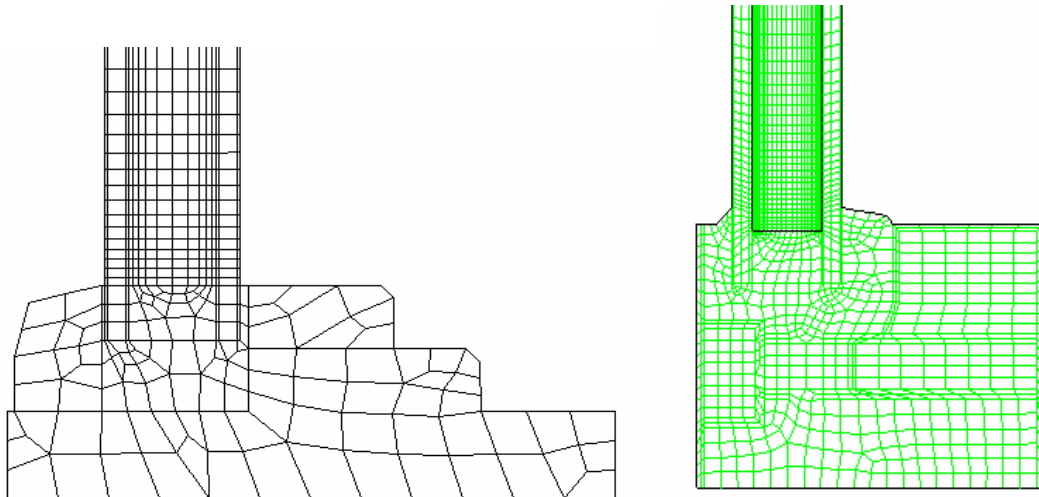
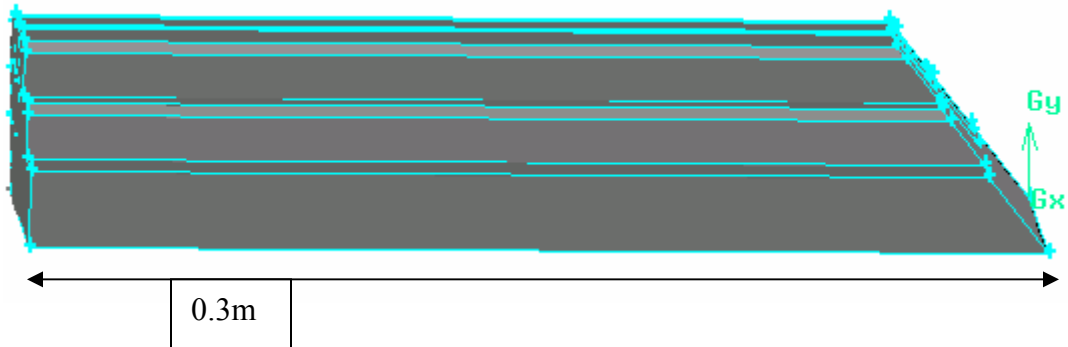

**Figure 6.2-1: Meshed view of the sill cross-sections of wood-window (Left) and AL/PVC window (Right)**

To create the 3-D model, each part sill, jamb, head, glazing unit has to be created.

There could be several ways to create. The sill cross-section is swept through the z-

direction by 0.3 m to create the sill volume. Then a plane cut one end at  $45^{\circ}$  to make the sill-jamb end. Figure 6.3 shows the sill part with one end cut by a plane at  $45^{\circ}$ . This part is meshed before proceeding for simplicity.



**Figure 6.2-2: Sill volume of wood-window in 3-D**

For meshing sill edges were meshed, then one end cross-section is meshed using ‘pave’ meshing scheme. The sill volume is meshed using ‘cooper’ scheme. Mirroring the meshed sill part at the required height creates head, which is already meshed. Then joining the ends of sill and head formed jamb and the glazing parts. Jamb is meshed using ‘cooper’ scheme while glazing parts are meshed using ‘map’ scheme.

Only on the inside surface we will have extra zones subdivided regions for better result processing and comparison. However, it would create problem in meshing if our grading scheme is not smooth through out the geometry. To overcome this, affected edges were also divided in accordance with the inside surface but no separate plane were created. It allows us to give the same meshing scheme and have a structured mesh. Figure 6.4 shows the two views of the modeled window. Figure 6.2-3(a) shows the inside plane which has been subdivided, while Figure 6.2-3(b) shows that outside plane has not been subdivided though edges have been divided.

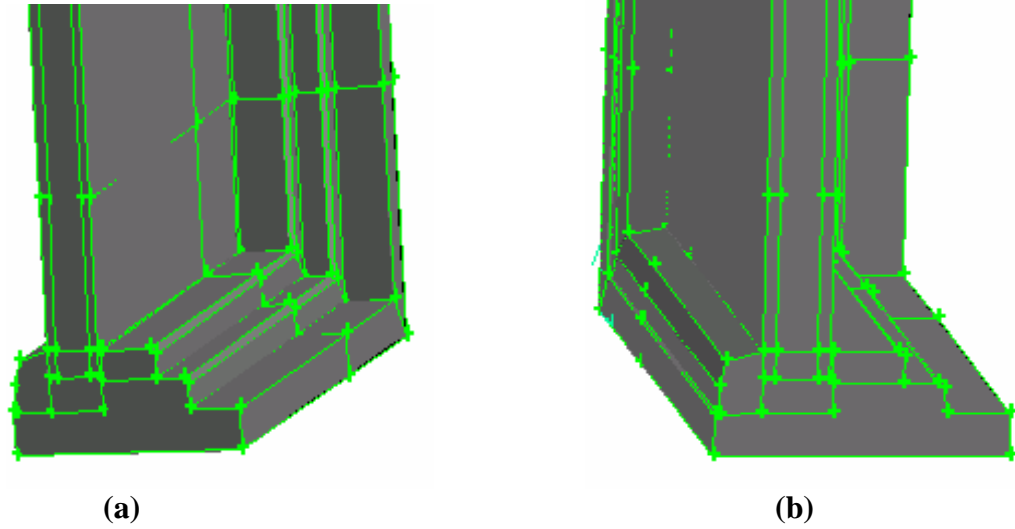

**Figure 6.2-3: Different views of the wood-window**

Figure 6.2-4 shows the meshed view of wood window. After meshing, continuum and boundary conditions are assigned to appropriate surfaces and volumes. Their quantitative values will be assigned in FLUENT. After defining the continuum and boundary conditions, mesh is exported as .msh file to be read in FLUENT.

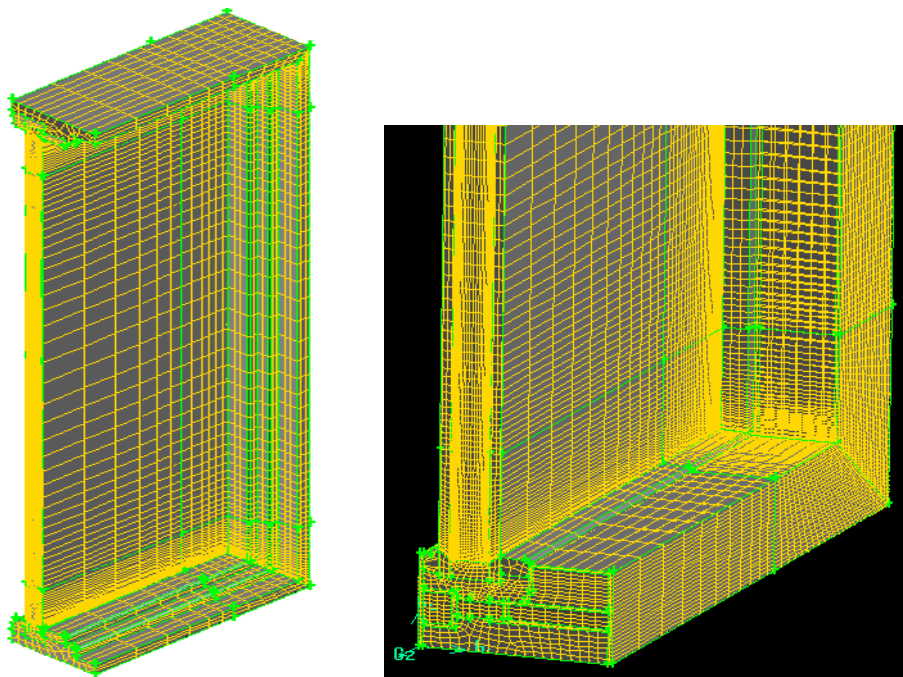

**Figure 6.2-4: Meshed view of window wood (left) and Al/PVC (right) windows**

### 6.3 Obtaining results from FLUENT: -

After assigning material's thermo-physical properties, appropriate boundary conditions, and selecting the appropriate solving model and discretization schemes, the solution is obtained for the heat transfer analysis.

#### Solution procedure:-

We used segregated solver. More description about the solving techniques are as follows:

Model	Settings
Space	2D, 3D
Time	Steady
Viscous	Laminar or turbulent ( <i>for convection models only</i> )
Heat Transfer	Enabled

#### Radiation model:

Discrete Transfer Radiation Model (DTRM), (6 theta division and 8-phi division used). Radiation models apply only to the convection models.

#### Discretization Scheme

Variable	Scheme
Pressure	PRESTO!
Pressure-Velocity Coupling	SIMPLE
Momentum	Second Order Upwind
Energy	First Order Upwind

Under-relaxation factors (RF) for all equations (variables) were defined as defaults

The flow regimes inside the glazing cavity will determine the selection of viscous model. It depends on the aspect ratio and Rayleigh Number. Fig 6.10 shows definition of different flow regimes.

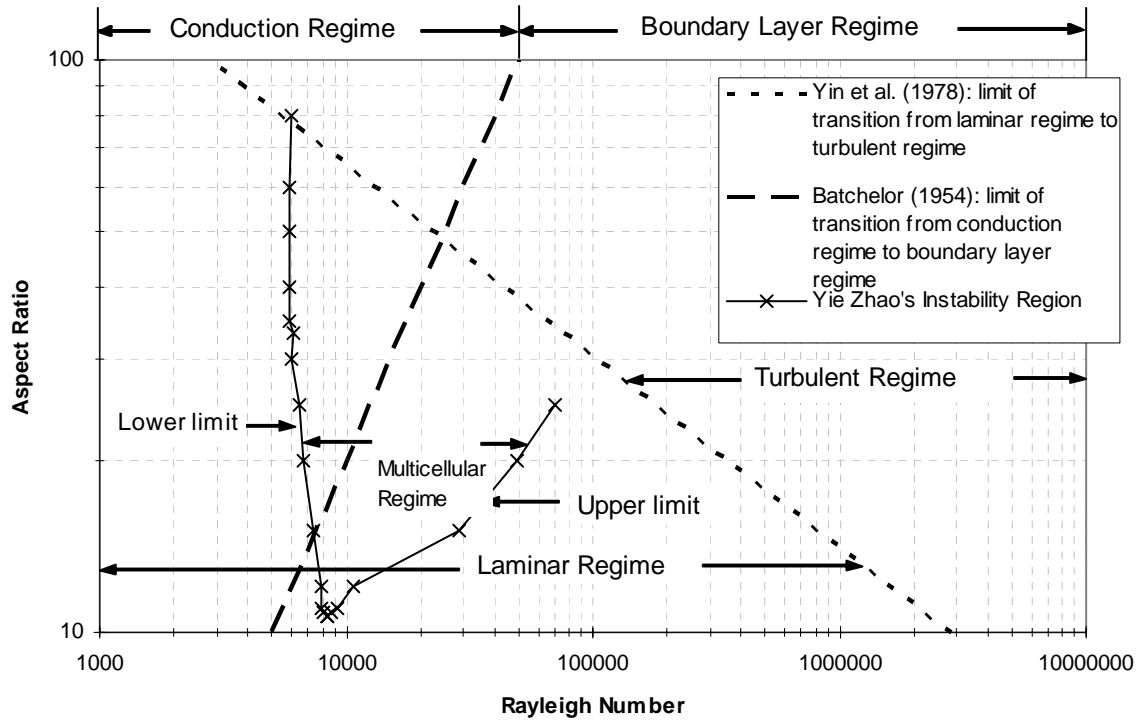

**Figure 6.3-1: Definition of different flow regimes**

The window model geometry has been divided-up into several regions (see Figure 6.3-1), so that each contribution to 3-D heat transfer can be separately accounted for. For example, sill portion of the frame is divided into the region farther from the corner, where pure 2-D effects dominate, while the corner region, which looks like trapezoid when viewed facing the window, is evaluated separately in order to understand the corner effects. Edge of glass near the corner and near the center of glass is also separately considered. This allows for better resolution of results and better understanding of 3-D heat transfer effects. Figure 6.3-2 shows full listing of all of subdivisions that were used for calculating heat transfer results. Another method was used to obtain equivalent 2-D\* results by extracting the heat transfer results from the 3-D model where the heat flow

was considered as 2-D. Figure 6.3-3 shows the areas of 3-D models from where the 2-D\* results were extracted.

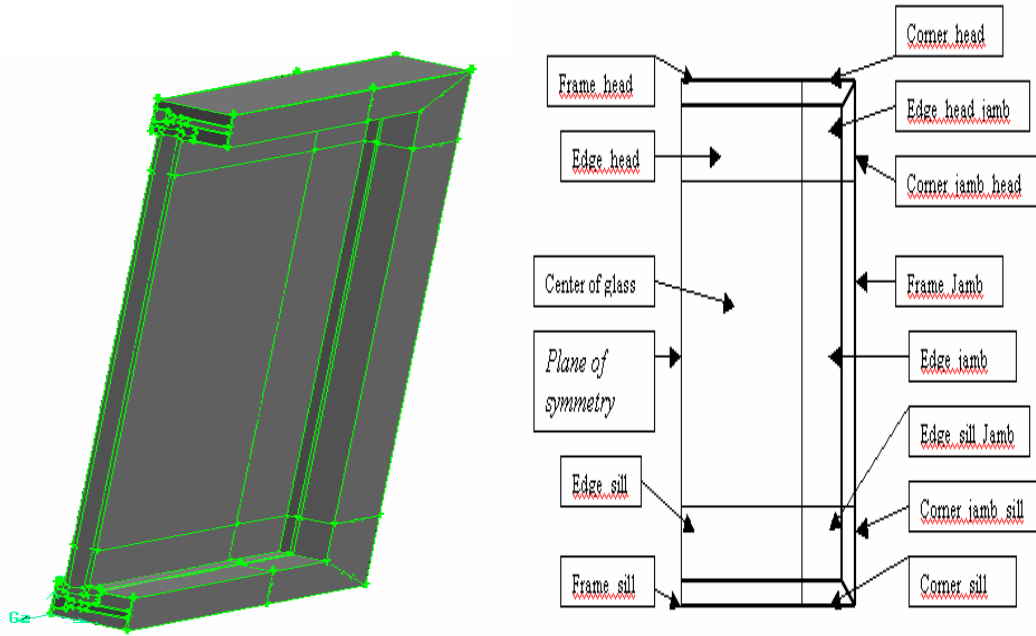

**Figure 6.3-2: Sub-division of 3-D Geometry for Better Resolution of Results**

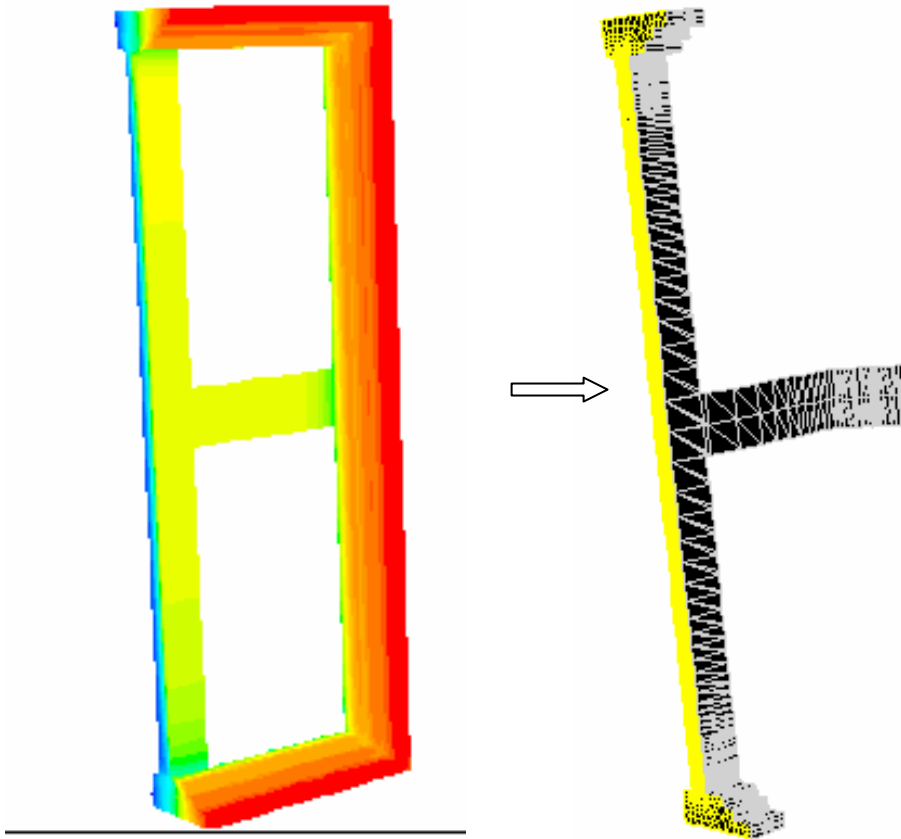

**Figure 6.3-3: Area of 3-D model (right) used for extracting 2-D\* Result (Wood window example)**

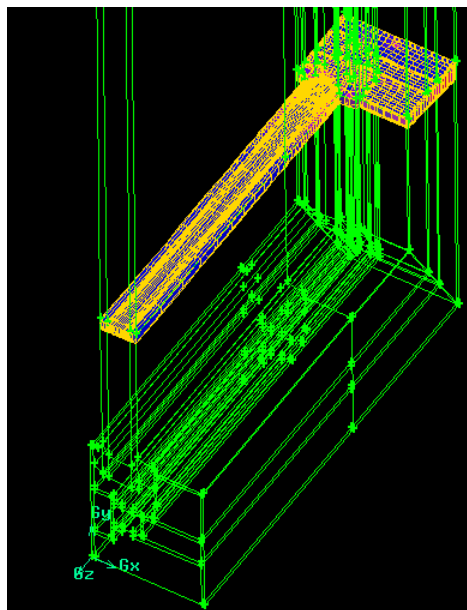

**Figure 6.3-4: 2-D Cross-Section From the 3-D Model of the Aluminum and PVC windows**

#### 6.4 Overall result and comparisons: -

FLUENT 3-D results were compared to FLUENT 2-D results for the conclusion about the 3-D heat transfer effects. This was done because it is the true “apples-to-apples” comparison that exposes the 3-D effects and most effectively eliminates noise in results. In other words, any small differences between THERM and FLUENT 2-D results will not affect comparison between 2-D and 3-D heat transfer results. In addition, 2-D and 3-D conduction model results were compared separately from 2-D and 3-D convection model results. On the other hand, results from THERM and WINDOW were compared to FLUENT 2-D (convection and conduction models) results to make sure that FLUENT models were sound and accurate representation of the fenestration models. Side benefit was further verification and validation of the accuracy of THERM program.

Table 6.4-1 to Table 6.4-8 show the overall window U-factor results from Window5/Therm5, 2-D FLUENT model, and 3-D FLUENT model for all windows. It also shows comparison between Therm5/Window5 results with 2-D FLUENT results and 2-D FLUENT results with 3-D FLUENT results. Table 6.4-1 to Table 6.4-4 are results for 2-D and 3-D FLUENT convection models and Table 6.4-5 to Table 6.4-8 show results with conduction models.

Percentage differences in overall U-factor results between Therm5/Window5 and 2-D models and 2-D and 3-D models are plotted against the center of glass U-factor in Figure 6.4-1 – Figure 6.4-8 for all the models. These results are the crux of all this investigation to estimate the overall impact and trends of 3-D heat transfer effects.



## 6.4.1 Overall U-factor results and comparisons for CONVECTION models

Table 6.4-1: Wood window result (convection models)

Size	Spacer cond. (W/mK)	Fill gas	Glazing	U-factor (W/m <sup>2</sup> K)				
				W5 / T5	FLUENT 2-D	% diff.	FLUENT 3-D	%diff. (3D-2D)
Large (1.5 x 1.2)	Low -0.05	Air	Clear-clear	2.6	2.50	-3.82%	2.51	0.37%
			Clear-low-e HC	1.76	1.64	-7.31%	1.65	0.40%
			Clear-low-e SC	1.55	1.41	-10.06%	1.42	0.72%
	Medium -0.674	Air	Clear-clear	2.76	2.67	-3.33%	2.68	0.37%
			Clear-low-e HC	1.96	1.85	-6.16%	1.86	0.59%
			Clear-low-e SC	1.76	1.63	-8.32%	1.64	0.91%
	High -1.9	Air	Clear-clear	2.83	2.73	-3.70%	2.74	0.48%
			Clear-low-e HC	2.04	1.92	-6.12%	1.93	0.70%
			Clear-low-e SC	1.84	1.71	-8.08%	1.72	0.99%
Medium (1.2 x 1.2)	Low -0.05	Air	Clear-clear	2.59	2.49	-3.72%	2.49	-0.01%
			Clear-low-e HC	1.76	1.65	-6.84%	1.66	0.48%
			Clear-low-e SC	1.56	1.42	-9.26%	1.44	0.81%
	Medium -0.674	Air	Clear-clear	2.76	2.67	-3.18%	2.67	0.13%
			Clear-low-e HC	1.97	1.87	-5.71%	1.88	0.80%
			Clear-low-e SC	1.78	1.65	-7.61%	1.67	1.12%
	High -1.9	Air	Clear-clear	2.83	2.74	-3.48%	2.74	0.15%
			Clear-low-e HC	2.05	1.95	-5.48%	1.96	0.79%
			Clear-low-e SC	1.86	1.74	-7.14%	1.76	1.12%
Small (0.9 x 1.2)	Low -0.05	Air	Clear-clear	2.57	2.48	-3.75%	2.48	0.14%
			Clear-low-e HC	1.76	1.62	-8.61%	1.64	1.16%
			Clear-low-e SC	1.56	1.40	-11.40%	1.43	1.73%
	Medium -0.674	Air	Clear-clear	2.75	2.67	-3.22%	2.67	0.27%
			Clear-low-e HC	1.99	1.86	-6.93%	1.89	1.18%
			Clear-low-e SC	1.8	1.66	-8.95%	1.68	1.64%
	High -1.9	Air	Clear-clear	2.83	2.74	-3.56%	2.74	0.30%
			Clear-low-e HC	2.08	1.95	-6.63%	1.97	1.15%
			Clear-low-e SC	1.9	1.75	-8.49%	1.77	1.58%

Note: HC:  $\epsilon = 0.16$ ; SC:  $\epsilon = 0.03$ ; Argon = 95% Argon & 5% Air

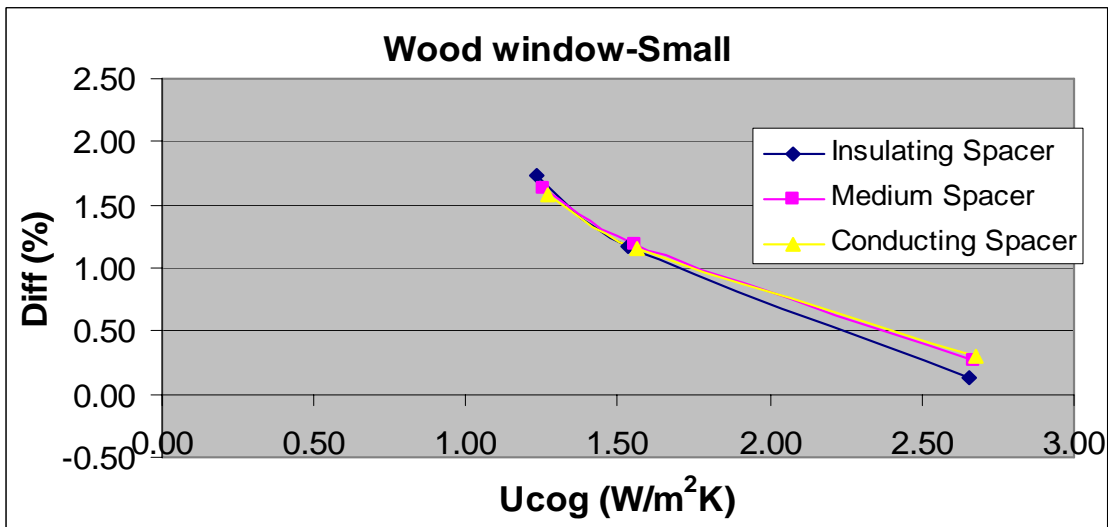
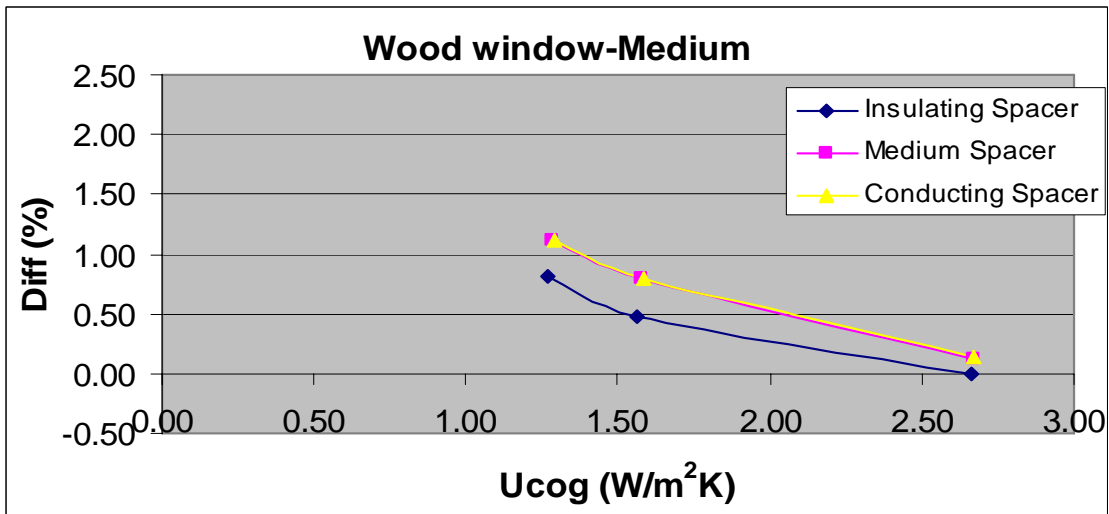
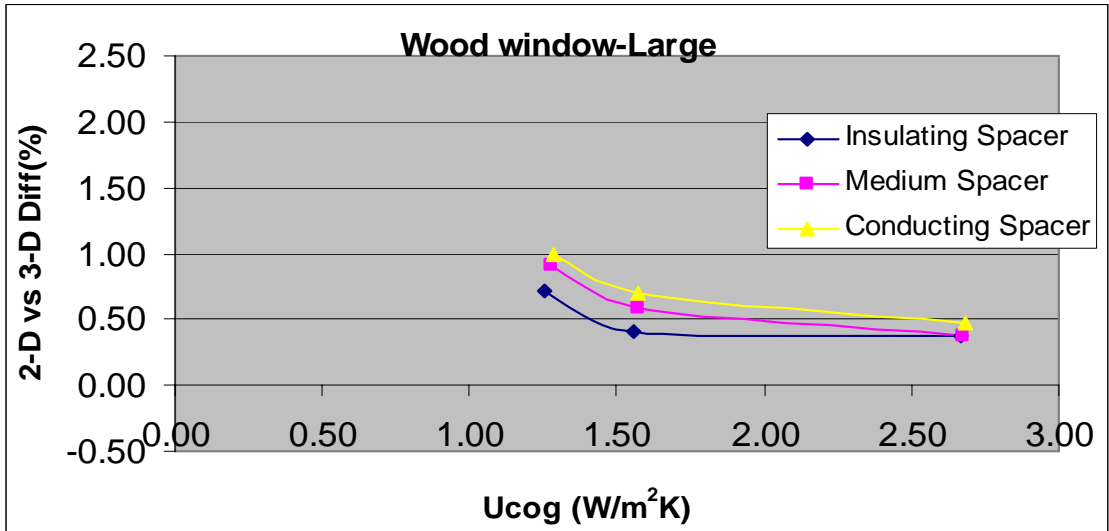
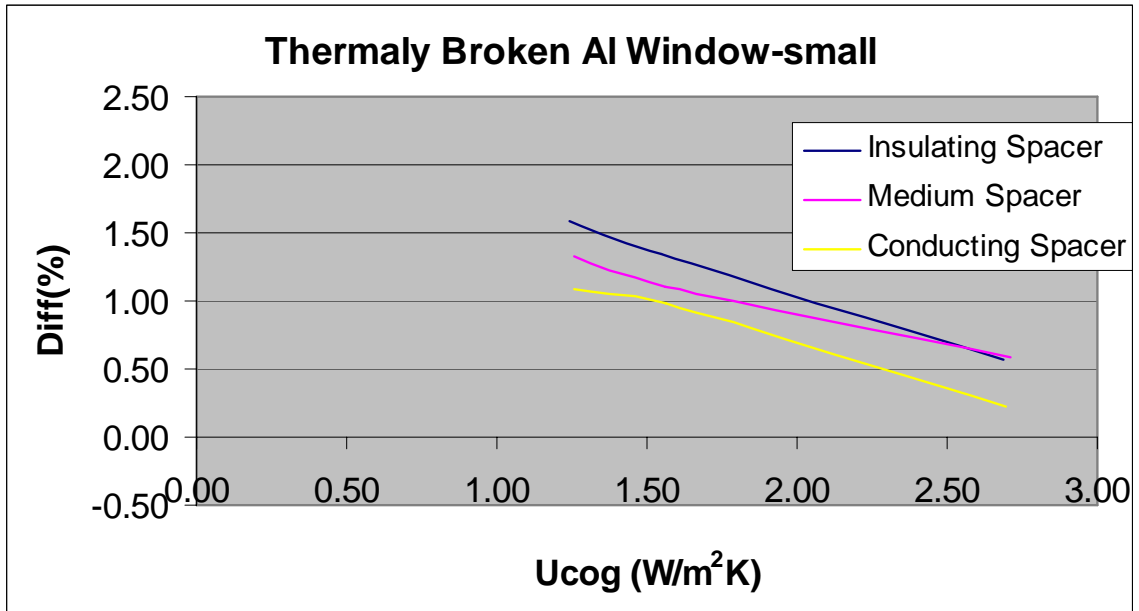

Figure 6.4-1: Overall 3-D vs 2-D Differences for Wood Window (convection models)

**Table 6.4-2: T/B AL window result (convection models)**

Size	Spacer cond. (W/mK)	Fill gas	Glazing	U-factor (W/m <sup>2</sup> K)				
				W5 / T5	FLUENT 2-D	% diff.	FLUENT 3-D	% diff. (3D-2D)
Small (0.9 x 1.2)	Low -0.05	Air	Clear-clear	3.572	3.43	-4.08%	3.45	0.56%
			Clear-low-e HC	2.832	2.65	-6.76%	2.69	1.35%
		Argon	Clear-low-e SC	2.653	2.45	-8.21%	2.49	1.58%
	Medium -0.674	Air	Clear-clear	3.718	3.59	-3.60%	3.61	0.58%
			Clear-low-e HC	3.014	2.85	-5.90%	2.88	1.10%
		Argon	Clear-low-e SC	2.842	2.66	-6.99%	2.69	1.34%
	High -1.9	Air	Clear-clear	3.793	3.65	-3.85%	3.66	0.22%
			Clear-low-e HC	3.103	2.93	-5.73%	2.96	0.98%
		Argon	Clear-low-e SC	2.934	2.75	-6.81%	2.78	1.08%

Note: HC:  $\epsilon = 0.16$ ; SC:  $\epsilon = 0.03$ ; Argon = 95% Argon & 5% Air

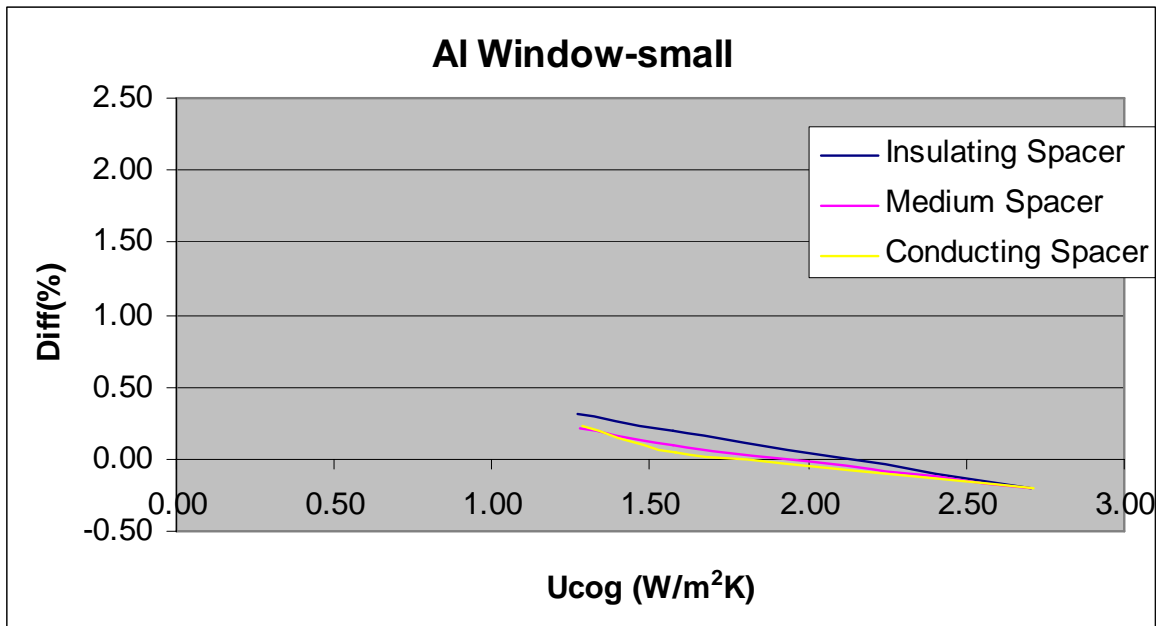

**Figure 6.4-2: Overall 3-D vs 2-D Differences for T/B Al Window**

**Table 6.4-3: Aluminum window result (convection models)**

Size	Spacer cond. (W/mK)	Fill gas	Glazing	U-factor (W/m <sup>2</sup> K)				
				W5 / T5	FLUENT 2-D	% diff.	FLUENT 3-D	%diff. (3D-2D)
Small (0.9 x 1.2)	Low -0.05	Air	Clear-clear	4.723	4.63	-1.96%	4.62	-0.20%
			Clear-low-e HC	4.024	3.90	-3.22%	3.91	0.19%
			Clear-low-e SC	3.851	3.71	-3.73%	3.72	0.31%
	Medium -0.674	Air	Clear-clear	4.771	4.67	-2.24%	4.66	-0.21%
			Clear-low-e HC	4.091	3.95	-3.63%	3.95	0.09%
			Clear-low-e SC	3.923	3.76	-4.26%	3.77	0.21%
	High -1.9	Air	Clear-clear	4.795	4.69	-2.35%	4.68	-0.21%
			Clear-low-e HC	4.122	3.97	-3.72%	3.98	0.04%
			Clear-low-e SC	3.956	3.79	-4.41%	3.80	0.23%

Note: HC:  $\epsilon = 0.16$ ; SC:  $\epsilon = 0.03$ ; Argon = 95% Argon & 5% Air

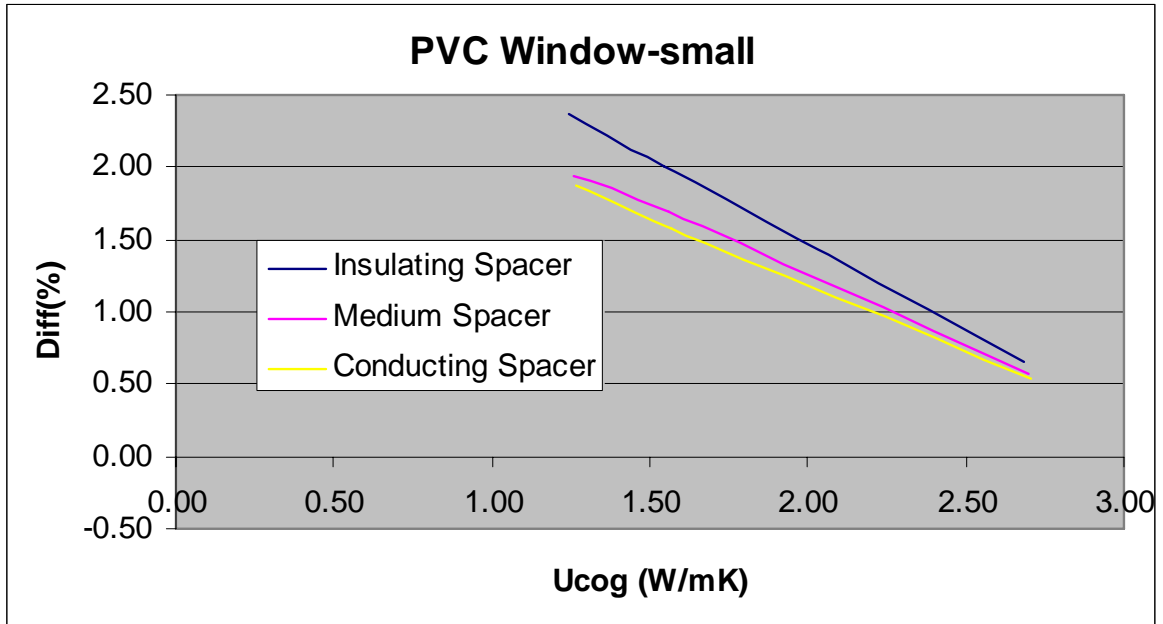

**Figure 6.4-3: Overall 3-D vs 2-D Differences for Al Window (convection models)**

**Table 6.4-4: PVC window result (convection models)**

Size	Spacer cond. (W/mK)	Fill gas	Glazing	U-factor (W/m <sup>2</sup> K)				
				W5 / T5	FLUENT 2-D	% diff.	FLUENT 3-D	% diff. (3D-2D)
Small (0.9 x 1.2)	Low -0.05	Air	Clear-clear	2.633	2.53	-4.23%	2.54	0.65%
			Clear-low-e HC	1.885	1.73	-8.70%	1.77	2.00%
		Argon	Clear-low-e SC	1.701	1.53	-11.10%	1.57	2.37%
	Medium -0.674	Air	Clear-clear	2.811	2.70	-4.05%	2.72	0.57%
			Clear-low-e HC	2.109	1.96	-7.83%	1.99	1.69%
		Argon	Clear-low-e SC	1.936	1.77	-9.61%	1.80	1.93%
	High -1.9	Air	Clear-clear	2.888	2.77	-4.19%	2.79	0.54%
			Clear-low-e HC	2.203	2.04	-7.83%	2.08	1.58%
		Argon	Clear-low-e SC	2.034	1.86	-9.62%	1.89	1.87%

Note: HC:  $\epsilon = 0.16$ ; SC:  $\epsilon = 0.03$ ; Argon = 95% Argon & 5% Air



**Figure 6.4-4: Overall 3-D vs 2-D Differences for PVC Window (convection models)**

## 6.4.2 Overall U-factor results and comparisons for CONDUCTION models

Table 6.4-5: Wood window result (Conduction models)

Size	Spacer cond. (W/mK)	Fill gas	Glazing	U-factor (W/m <sup>2</sup> K)				
				W5 / T5	FLUENT 2-D	% diff.	FLUENT 3-D	% diff. (3D-2D)
Large (0.6 x 1.5)	Low (0.05)	Air	Clear-clear	2.60	2.58	-0.52%	2.58	-0.21%
		Argon	Clear-low-e HC	1.76	1.75	-0.23%	1.76	0.07%
			Clear-low-e SC	1.55	1.53	-1.42%	1.53	0.22%
		Hypothetic	R10	0.86	0.84	-2.45%	0.85	1.24%
	Medium (0.674)	Air	Clear-clear	2.76	2.76	-0.06%	2.75	-0.13%
		Argon	Clear-low-e HC	1.96	1.97	0.57%	1.98	0.23%
			Clear-low-e SC	1.76	1.76	-0.31%	1.77	0.40%
		Hypothetic	R10	1.12	1.11	-0.81%	1.12	1.45%
	High (1.9)	Air	Clear-clear	2.83	2.82	-0.33%	2.82	-0.14%
		Argon	Clear-low-e HC	2.04	2.05	0.58%	2.05	0.21%
			Clear-low-e SC	1.84	1.84	-0.24%	1.85	0.39%
		Hypothetic	R10	1.21	1.20	-1.31%	1.21	1.41%
Medium (0.6 x 1.2)	Low (0.05)	Air	Clear-clear	2.59	2.57	-0.54%	2.57	-0.26%
		Argon	Clear-low-e HC	1.76	1.76	-0.24%	1.76	0.08%
			Clear-low-e SC	1.56	1.53	-1.47%	1.54	0.26%
		Hypothetic	R10	0.88	0.86	-2.37%	0.87	1.42%
	Medium (0.674)	Air	Clear-clear	2.76	2.75	-0.07%	2.75	-0.11%
		Argon	Clear-low-e HC	1.97	1.98	0.57%	1.99	0.35%
			Clear-low-e SC	1.78	1.77	-0.28%	1.79	0.57%
		Hypothetic	R10	1.14	1.14	-0.73%	1.16	1.77%
	High (1.9)	Air	Clear-clear	2.83	2.82	-0.36%	2.82	-0.08%
		Argon	Clear-low-e HC	2.05	2.07	0.59%	2.07	0.41%
			Clear-low-e SC	1.86	1.86	-0.15%	1.87	0.64%
		Hypothetic	R10	1.25	1.23	-1.17%	1.25	1.83%
Small (0.6 x 0.9)	Low (0.05)	Air	Clear-clear	2.57	2.55	-0.64%	2.55	-0.28%
		Argon	Clear-low-e HC	1.76	1.76	-0.35%	1.76	0.11%
			Clear-low-e SC	1.56	1.54	-1.49%	1.54	0.34%
	Medium (0.674)	Air	Clear-clear	2.75	2.75	-0.09%	2.74	-0.16%
		Argon	Clear-low-e HC	1.99	2.00	0.53%	2.01	0.34%
			Clear-low-e SC	1.80	1.80	-0.25%	1.81	0.58%
	High (1.9)	Air	Clear-clear	2.83	2.82	-0.40%	2.82	-0.17%
		Argon	Clear-low-e HC	2.08	2.09	0.55%	2.09	-0.02%
			Clear-low-e SC	1.90	1.89	-0.19%	1.90	0.58%

Note: HC:  $\epsilon = 0.16$ ; SC:  $\epsilon = 0.03$ ; Argon = 95% Argon & 5% Air

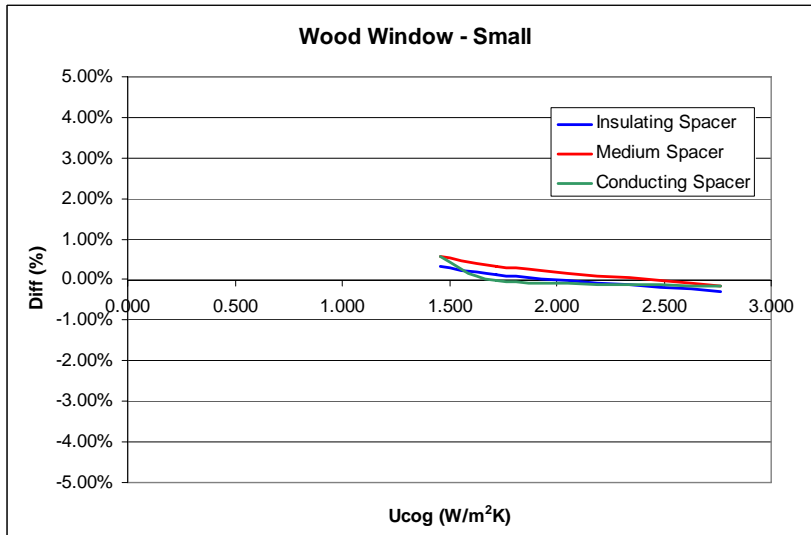
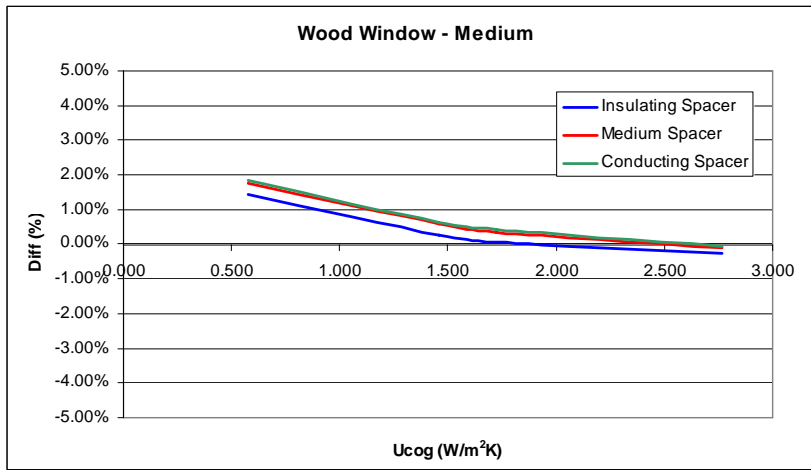

**Figure 6.4-5 : 3-D vs 2-D Differences for Wood Window (Conduction models)**

**Table 6.4-6: T/B AL window result (Conduction models)**

Size	Spacer cond. (W/mK)	Fill gas	Glazing	U-factor (W/m <sup>2</sup> K)				
				W5 / T5	FLUENT 2-D	% diff.	FLUENT 3-D	% diff. (3D-2D)
Large (0.6 x 1.5)	Low (0.05)	Air	Clear-clear	3.48	3.41	-2.07%	3.43	0.54%
		Argon	Clear-low-e HC	2.70	2.65	-2.11%	2.67	1.03%
			Clear-low-e SC	2.51	2.44	-2.99%	2.47	1.25%
		Hypothetic	R10	1.87	1.83	-2.44%	1.85	1.07%
	Medium (0.674)	Air	Clear-clear	3.61	3.55	-1.62%	3.57	0.53%
		Argon	Clear-low-e HC	2.86	2.82	-1.85%	2.85	1.01%
			Clear-low-e SC	2.68	2.62	-2.29%	2.65	1.23%
		Hypothetic	R10	2.07	2.03	-1.57%	2.05	0.93%
	High (1.9)	Air	Clear-clear	3.68	3.62	-1.61%	3.64	0.51%
		Argon	Clear-low-e HC	2.94	2.89	-1.54%	2.92	0.96%
			Clear-low-e SC	2.76	2.70	-2.26%	2.73	1.14%
		Hypothetic	R10	2.16	2.12	-1.62%	2.14	0.91%
Medium (0.6 x 1.2)	Low (0.05)	Air	Clear-clear	3.52	3.47	-1.51%	3.45	-0.43%
		Argon	Clear-low-e HC	2.75	2.71	-1.38%	2.71	-0.15%
			Clear-low-e SC	2.57	2.51	-2.21%	2.51	-0.02%
		Hypothetic	R10	1.94	1.90	-2.50%	1.91	0.60%
	Medium (0.674)	Air	Clear-clear	3.65	3.62	-1.00%	3.60	-0.48%
		Argon	Clear-low-e HC	2.92	2.90	-0.80%	2.89	-0.15%
			Clear-low-e SC	2.74	2.70	-1.44%	2.70	-0.01%
		Hypothetic	R10	2.15	2.11	-1.61%	2.13	0.62%
	High (1.9)	Air	Clear-clear	3.72	3.68	-0.98%	3.67	-0.44%
		Argon	Clear-low-e HC	3.00	2.98	-0.81%	2.98	-0.09%
			Clear-low-e SC	2.83	2.79	-1.41%	2.79	0.05%
		Hypothetic	R10	2.24	2.21	-1.61%	2.22	0.74%
Small (0.6 x 0.9)	Low (0.05)	Air	Clear-clear	3.57	3.52	-1.58%	3.52	0.24%
		Argon	Clear-low-e HC	2.83	2.79	-1.53%	2.81	0.85%
			Clear-low-e SC	2.65	2.59	-2.27%	2.61	0.53%
	Medium (0.674)	Air	Clear-clear	3.72	3.68	-1.02%	3.68	0.01%
		Argon	Clear-low-e HC	3.01	2.99	-0.83%	3.00	0.42%
			Clear-low-e SC	2.84	2.80	-1.42%	2.83	0.88%
	High (1.9)	Air	Clear-clear	3.79	3.76	-1.01%	3.75	-0.17%
		Argon	Clear-low-e HC	3.10	3.08	-0.84%	3.09	0.37%
			Clear-low-e SC	2.93	2.89	-1.41%	2.91	0.55%

Note: HC:  $\epsilon = 0.16$ ; SC:  $\epsilon = 0.03$ ; Argon = 95% Argon & 5% Air



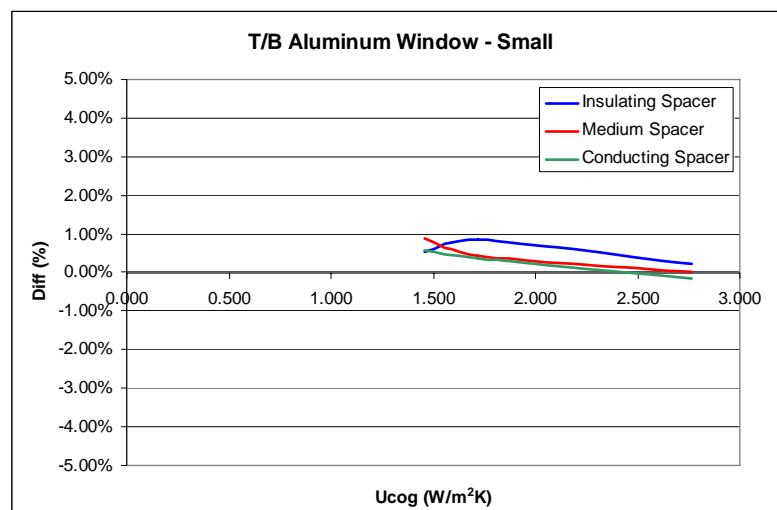
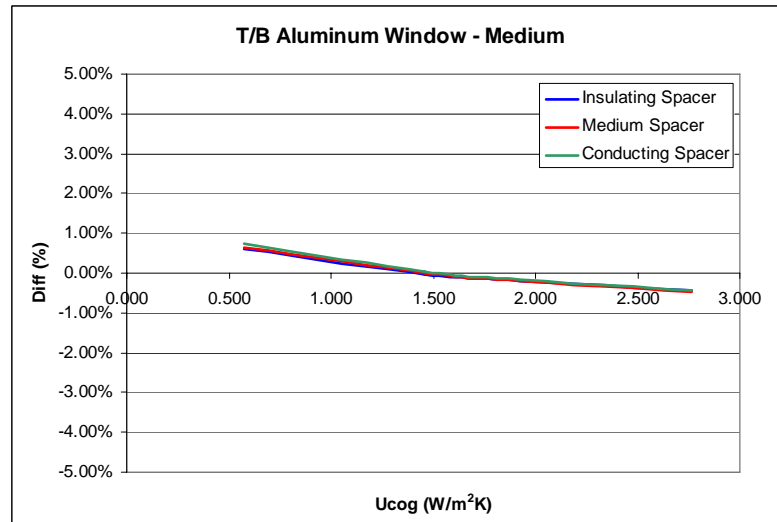
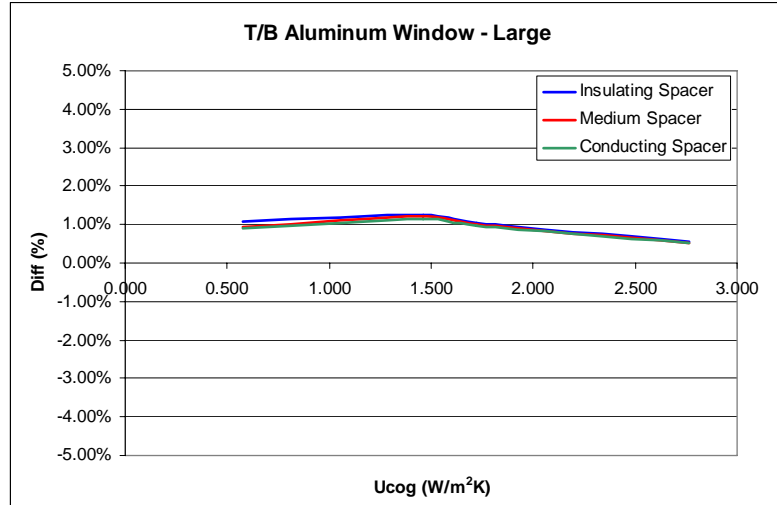

**Figure 6.4-6: 3-D vs 2-D Differences for T/B AL Window (Conduction models)**

**Table 6.4-7: AL window result (Conduction models)**

Size	Spacer cond. (W/mK)	Fill gas	Glazing	U-factor (W/m <sup>2</sup> K)				
				W5 / T5	FLUENT 2-D	% diff.	FLUENT 3-D	% diff. (3D-2D)
Large (0.6 x 1.5)	Low (0.05)	Air	Clear-clear	4.47	4.47	0.02%	4.45	-0.42%
		Argon	Clear-low-e HC	3.72	3.74	0.45%	3.73	-0.34%
			Clear-low-e SC	3.54	3.54	0.09%	3.53	-0.28%
		Hypothetic	R10	2.91	2.94	0.80%	2.94	0.05%
	Medium (0.674)	Air	Clear-clear	4.51	4.50	-0.18%	4.49	-0.30%
		Argon	Clear-low-e HC	3.78	3.79	0.05%	3.78	-0.25%
			Clear-low-e SC	3.61	3.59	-0.39%	3.59	-0.02%
		Hypothetic	R10	3.00	3.00	-0.27%	3.00	0.11%
	High (1.9)	Air	Clear-clear	4.53	4.52	-0.28%	4.51	-0.29%
		Argon	Clear-low-e HC	3.81	3.81	-0.09%	3.80	-0.23%
			Clear-low-e SC	3.63	3.62	-0.51%	3.61	-0.22%
		Hypothetic	R10	3.04	3.02	-0.52%	3.03	0.14%
Medium (0.6 x 1.2)	Low (0.05)	Air	Clear-clear	4.57	4.57	-0.01%	4.51	-1.38%
		Argon	Clear-low-e HC	3.84	3.86	0.38%	3.80	-1.35%
			Clear-low-e SC	3.66	3.66	0.01%	3.61	-1.37%
		Hypothetic	R10	3.05	3.08	0.79%	3.04	-1.24%
	Medium (0.674)	Air	Clear-clear	4.61	4.60	-0.22%	4.54	-1.31%
		Argon	Clear-low-e HC	3.90	3.90	-0.01%	3.86	-1.23%
			Clear-low-e SC	3.73	3.71	-0.41%	3.67	-1.19%
		Hypothetic	R10	3.14	3.14	-0.22%	3.10	-1.01%
	High (1.9)	Air	Clear-clear	4.64	4.62	-0.33%	4.56	-1.26%
		Argon	Clear-low-e HC	3.93	3.93	-0.15%	3.88	-1.15%
			Clear-low-e SC	3.76	3.74	-0.58%	3.70	-1.10%
		Hypothetic	R10	3.18	3.15	-1.13%	3.14	-0.25%
Small (0.6 x 0.9)	Low (0.05)	Air	Clear-clear	4.72	4.72	0.03%	4.69	-0.71%
		Argon	Clear-low-e HC	4.02	4.04	0.40%	4.02	-0.49%
			Clear-low-e SC	3.85	3.85	0.10%	3.84	-0.35%
	Medium (0.674)	Air	Clear-clear	4.77	4.76	-0.16%	4.73	-0.71%
		Argon	Clear-low-e HC	4.09	4.09	0.01%	4.07	-0.48%
			Clear-low-e SC	3.92	3.91	-0.34%	3.89	-0.39%
	High (1.9)	Air	Clear-clear	4.80	4.78	-0.25%	4.75	-0.72%
		Argon	Clear-low-e HC	4.12	4.12	-0.10%	4.10	-0.56%
			Clear-low-e SC	3.96	3.94	-0.47%	3.92	-0.51%

Note: HC:  $\epsilon = 0.16$ ; SC:  $\epsilon = 0.03$ ; Argon = 95% Argon & 5% Air

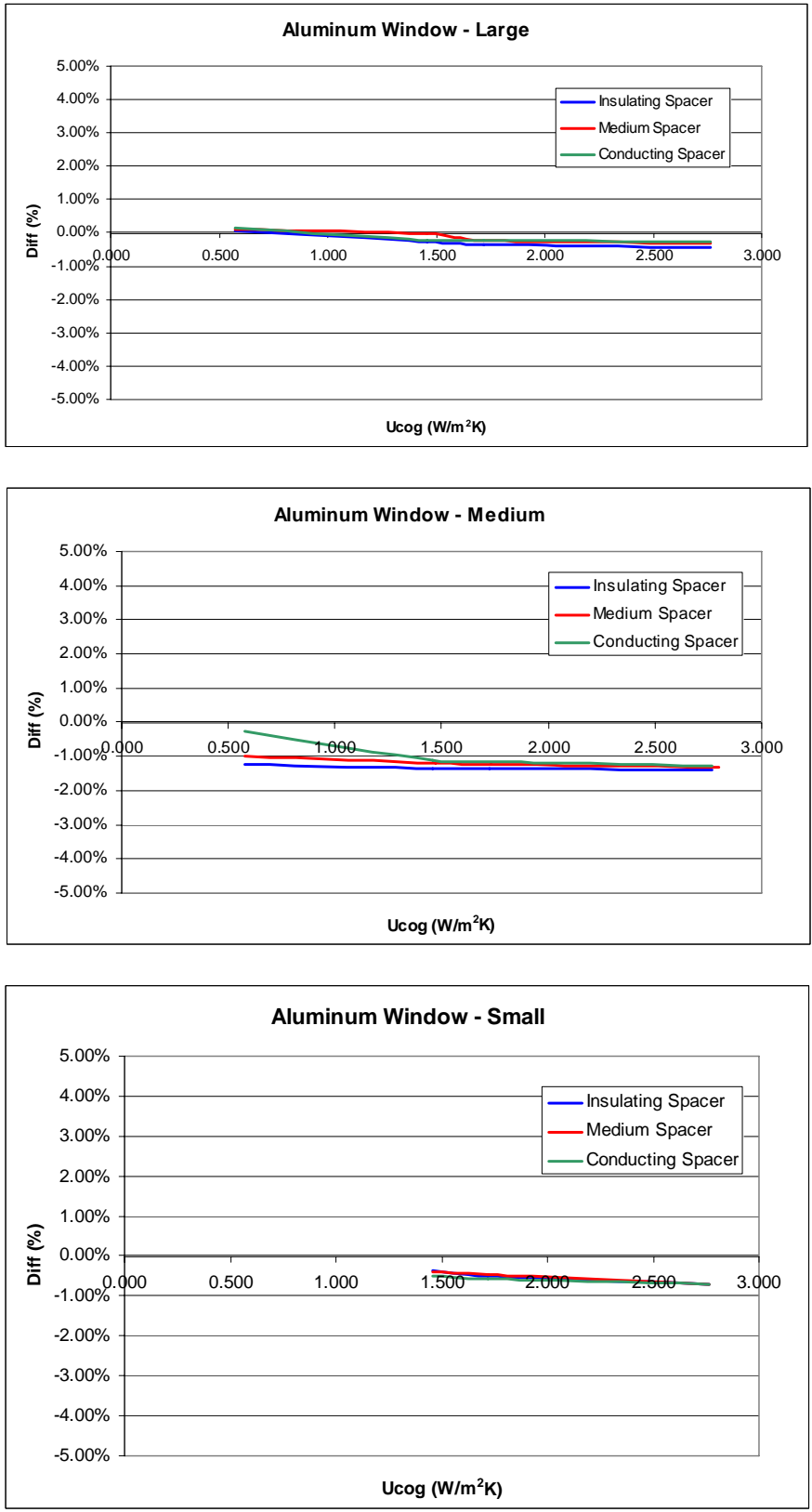

Figure 6.4-7: 3-D vs 2-D Differences for AL Window (Conduction models)

**Table 6.4-8: PVC window result (Conduction models)**

Size	Spacer cond. (W/mK)	Fill gas	Glazing	U-factor (W/m <sup>2</sup> K)				
				W5 / T5	FLUENT 2-D	% diff.	FLUENT 3-D	% diff. (3D-2D)
Large (0.6 x 1.5)	Low (0.05)	Air	Clear-clear	2.66	2.64	-0.85%	2.64	-0.03%
		Argon	Clear-low-e HC	1.88	1.86	-0.64%	1.87	0.40%
			Clear-low-e SC	1.68	1.65	-1.73%	1.66	0.59%
		Hypothetic	R10	1.01	1.01	0.24%	1.03	1.73%
	Medium (0.674)	Air	Clear-clear	2.82	2.80	-0.84%	2.80	-0.01%
		Argon	Clear-low-e HC	2.07	2.06	-0.59%	2.07	0.44%
			Clear-low-e SC	1.89	1.86	-1.52%	1.87	0.61%
		Hypothetic	R10	1.24	1.25	0.94%	1.27	1.70%
	High (1.9)	Air	Clear-clear	2.89	2.86	-1.00%	2.86	0.01%
		Argon	Clear-low-e HC	2.16	2.14	-0.98%	2.14	0.45%
			Clear-low-e SC	1.98	1.94	-1.88%	1.95	0.69%
		Hypothetic	R10	1.34	1.34	0.40%	1.36	1.72%
Medium (0.6 x 1.2)	Low (0.05)	Air	Clear-clear	2.65	2.63	-0.81%	2.63	-0.09%
		Argon	Clear-low-e HC	1.88	1.87	-0.54%	1.88	0.33%
			Clear-low-e SC	1.69	1.66	-1.59%	1.67	0.53%
		Hypothetic	R10	1.03	1.04	0.66%	1.05	1.70%
	Medium (0.674)	Air	Clear-clear	2.82	2.79	-0.82%	2.80	0.20%
		Argon	Clear-low-e HC	2.09	2.07	-0.56%	2.09	0.84%
			Clear-low-e SC	1.91	1.88	-1.47%	1.90	1.11%
		Hypothetic	R10	1.27	1.29	1.18%	1.32	2.52%
	High (1.9)	Air	Clear-clear	2.89	2.86	-1.02%	2.87	0.31%
		Argon	Clear-low-e HC	2.17	2.15	-0.96%	2.18	1.02%
			Clear-low-e SC	2.00	1.96	-1.85%	1.99	1.32%
		Hypothetic	R10	1.37	1.38	0.57%	1.42	2.80%
Small (0.6 x 0.9)	Low (0.05)	Air	Clear-clear	2.63	2.61	-0.93%	2.61	-0.14%
		Argon	Clear-low-e HC	1.89	1.87	-0.72%	1.88	0.41%
			Clear-low-e SC	1.70	1.67	-1.74%	1.68	0.65%
	Medium (0.674)	Air	Clear-clear	2.81	2.79	-0.90%	2.78	-0.13%
		Argon	Clear-low-e HC	2.11	2.09	-0.68%	2.10	0.38%
			Clear-low-e SC	1.94	1.91	-1.51%	1.92	0.64%
	High (1.9)	Air	Clear-clear	2.89	2.86	-1.09%	2.85	-0.15%
		Argon	Clear-low-e HC	2.20	2.18	-1.06%	2.19	0.47%
			Clear-low-e SC	2.03	2.00	-1.90%	2.01	0.68%

Note: HC:  $\epsilon = 0.16$ ; SC:  $\epsilon = 0.03$ ; Argon = 95% Argon & 5% Air

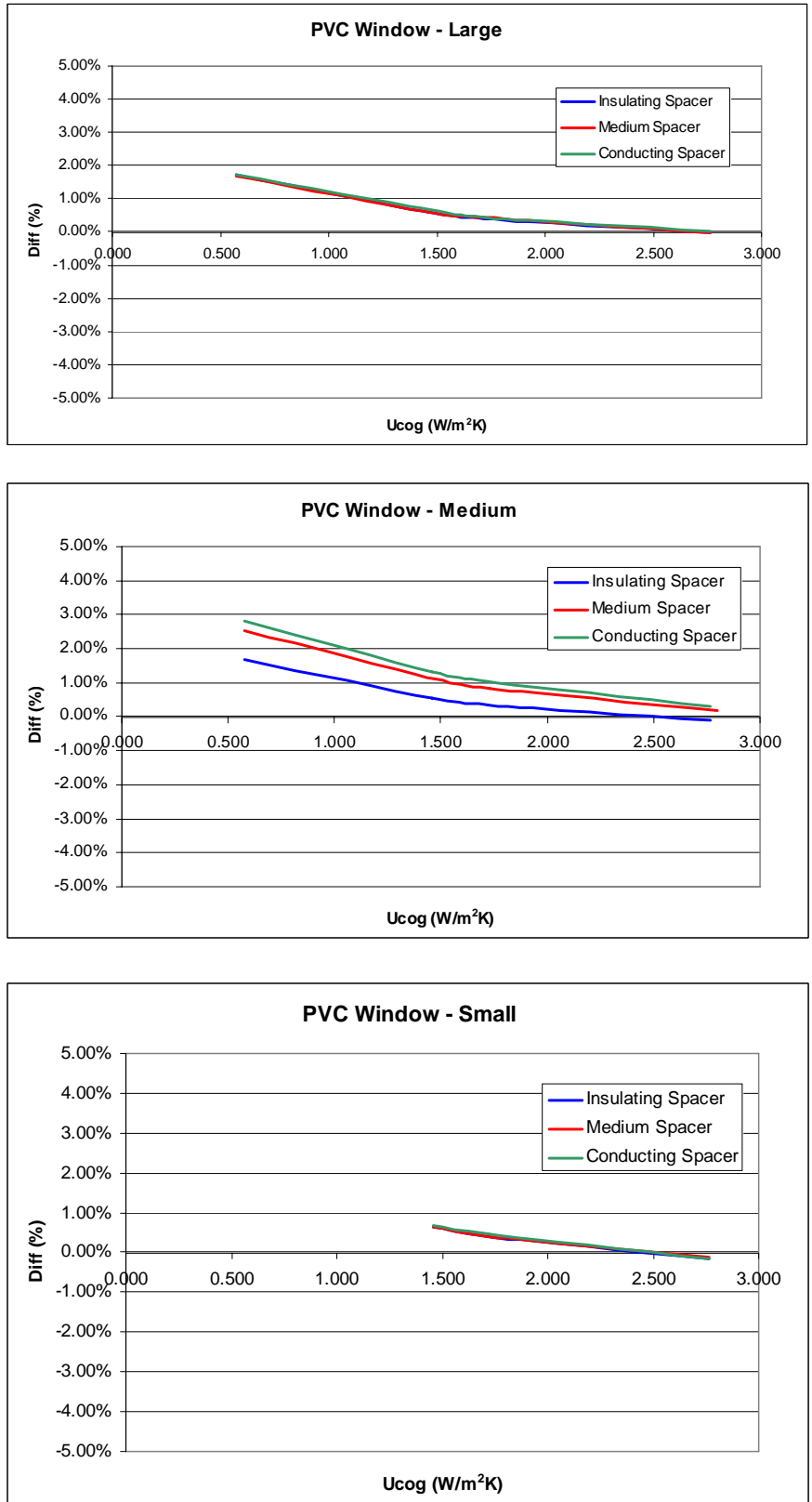

Figure 6.4-8: 3-D vs 2-D Differences for PVC Window (conduction Model)

## **6.5 Component level results and comparisons for convection and conduction models**

Detailed component level results for all models have been presented in the Table 6.5-1 to Table 6.5-18 (for convection models) and Table 6.5-19 - Table 6.5-54 (for conduction models). They present component level and overall product U-factor results and comparison between Therm/Window vs. 2-D FLUENT results, Therm/Window vs. 2-D\* FLUENT results (extracted from 3-D results), and FLUENT 2-D vs. FLUENT 3-D results. Figure 6.5-1 – Figure 6.5-18 show the component level U-factor differences between 2-D and 3-D models by plotting the percentage difference in U-factor vs. IGU performance for each spacer and window size. IGU performance was a key indicator of the effect of 3-D effects.

### 6.5.1 Component level results and comparisons for wood window (convection models)

**Table 6.5-1: Wood Window – Small Size, Insulating Spacer (convection models)**

Double Clear	Spacer Keff = 0.05 W/mK						
Section	T5/W5	2d	% diff	2D*	% diff	3d-overal	% diff
	W/m <sup>2</sup> K	W/m <sup>2</sup> K	2D vs. T5/W5	W/m <sup>2</sup> K	2D* vs. T5/W5	W/m <sup>2</sup> K	3D vs 2D
Frame_sill	1.87	2.07	11%	2.07	11%	2.00	-3.6%
Frame_head	1.87	1.64	-12%	1.61	-14%	1.61	-1.5%
Frame_jamb	1.89	1.77	-7%	1.77	-7%	1.78	0.7%
Center of glass	2.77	2.66	-4%	2.66	-4%	2.66	-0.2%
Edge_sill	2.76	3.32	20%	3.32	20%	3.31	-0.5%
Edge_head	2.76	2.29	-17%	2.29	-17%	2.30	0.4%
Edge_jamb	2.77	2.61	-6%	2.61	-6%	2.66	1.9%
<b>TOTAL</b>	<b>2.57</b>	<b>2.48</b>	<b>-4%</b>	<b>2.47</b>	<b>-4%</b>	<b>2.48</b>	<b>0.1%</b>
Double Low-e HC	Spacer Keff = 0.05 W/mK						
Section	T5/W5	2d	% diff	2D*	% diff	3d-overal	% diff
	W/m <sup>2</sup> K	W/m <sup>2</sup> K	2D vs. T5/W5	W/m <sup>2</sup> K	2D* vs. T5/W5	W/m <sup>2</sup> K	3D vs 2D
Frame_sill	1.68	1.96	17%	1.96	17%	1.90	-3.0%
Frame_head	1.68	1.44	-14%	1.42	-15%	1.44	0.2%
Frame_jamb	1.72	1.61	-6%	1.61	-6%	1.64	1.6%
Center of glass	1.72	1.53	-11%	1.53	-11%	1.53	0.3%
Edge_sill	1.88	2.64	40%	2.64	40%	2.64	0.2%
Edge_head	1.88	1.22	-35%	1.23	-35%	1.27	4.5%
Edge_jamb	1.89	1.68	-11%	1.68	-11%	1.75	4.7%
<b>TOTAL</b>	<b>1.76</b>	<b>1.62</b>	<b>-8%</b>	<b>1.62</b>	<b>-8%</b>	<b>1.64</b>	<b>1.2%</b>
Double Low-e sC	Spacer Keff = 0.05 W/mK						
Section	T5/W5	2d	% diff	2D*	% diff	3d-overal	% diff
	W/m <sup>2</sup> K	W/m <sup>2</sup> K	2D vs. T5/W5	W/m <sup>2</sup> K	2D* vs. T5/W5	W/m <sup>2</sup> K	3D vs 2D
Frame_sill	1.63	1.95	19%	1.95	19%	1.89	-3.0%
Frame_head	1.63	1.38	-15%	1.36	-17%	1.49	7.7%
Frame_jamb	1.66	1.58	-5%	1.58	-5%	1.57	-0.1%
Center of glass	1.46	1.23	-16%	1.23	-16%	1.23	0.6%
Edge_sill	1.67	2.51	50%	2.51	50%	2.52	0.3%
Edge_head	1.67	0.91	-45%	0.93	-44%	0.98	7.8%
Edge_jamb	1.68	1.44	-14%	1.44	-14%	1.53	6.2%
<b>TOTAL</b>	<b>1.56</b>	<b>1.40</b>	<b>-10%</b>	<b>1.40</b>	<b>-10%</b>	<b>1.43</b>	<b>1.8%</b>

**Table 6.5-2: Wood Window – Small Size, Medium Conducting Spacer (convection models)**

<b>Double Clear</b>	<b>Spacer Keff = 0.6742 W/mK</b>						
<b>Section</b>	<b>T5/W5</b>	<b>2d</b>	<b>% diff</b>	<b>2D*</b>	<b>% diff</b>	<b>3d-overal</b>	<b>% diff</b>
	<b>W/m<sup>2</sup>K</b>	<b>W/m<sup>2</sup>K</b>	<b>2D vs. T5/W5</b>	<b>W/m<sup>2</sup>K</b>	<b>2D* vs. T5/W5</b>	<b>W/m<sup>2</sup>K</b>	<b>3D vs 2D</b>
Frame sill	2.33	2.50	7%	2.50	7%	2.40	-3.8%
Frame head	2.33	2.12	-9%	2.09	-10%	2.07	-2.3%
Frame jamb	2.33	2.26	-3%	2.26	-3%	2.25	-0.3%
Center of glass	2.77	2.67	-4%	2.67	-3%	2.67	0.1%
Edge sill	3.05	3.56	17%	3.56	17%	3.58	0.4%
Edge head	3.05	2.56	-16%	2.57	-16%	2.62	2.1%
Edge jamb	3.05	2.91	-5%	2.91	-5%	2.96	2.0%
<b>TOTAL</b>	<b>2.75</b>	<b>2.67</b>	<b>-3%</b>	<b>2.67</b>	<b>-3%</b>	<b>2.67</b>	<b>0.3%</b>
<b>Double Low-e HC</b>	<b>Spacer Keff = 0.6742 W/mK</b>						
<b>Section</b>	<b>T5/W5</b>	<b>2d</b>	<b>% diff</b>	<b>2D*</b>	<b>% diff</b>	<b>3d-overal</b>	<b>% diff</b>
	<b>W/m<sup>2</sup>K</b>	<b>W/m<sup>2</sup>K</b>	<b>2D vs. T5/W5</b>	<b>W/m<sup>2</sup>K</b>	<b>2D* vs. T5/W5</b>	<b>W/m<sup>2</sup>K</b>	<b>3D vs 2D</b>
Frame sill	<b>2.23</b>	2.45	10%	1.64	-27%	2.36	-3.6%
Frame head	<b>2.23</b>	2.03	-9%	1.61	-28%	1.99	-1.7%
Frame jamb	<b>2.25</b>	2.19	-3%	2.19	-3%	2.19	-0.1%
<b>Center of glass</b>	<b>1.72</b>	1.54	-11%	1.74	1%	1.55	0.9%
Edge sill	<b>2.27</b>	2.96	30%	1.88	-17%	2.99	1.2%
Edge head	<b>2.27</b>	1.60	-29%	1.88	-17%	1.71	6.7%
Edge jamb	<b>2.27</b>	2.09	-8%	2.09	-8%	2.17	3.9%
<b>TOTAL</b>	<b>1.99</b>	<b>1.86</b>	<b>-6%</b>	<b>1.87</b>	<b>-6%</b>	<b>1.89</b>	<b>1.2%</b>
<b>Double Low-e sC</b>	<b>Spacer Keff = 0.6742 W/mK</b>						
<b>Section</b>	<b>T5/W5</b>	<b>2d</b>	<b>% diff</b>	<b>2D*</b>	<b>% diff</b>	<b>3d-overal</b>	<b>% diff</b>
	<b>W/m<sup>2</sup>K</b>	<b>W/m<sup>2</sup>K</b>	<b>2D vs. T5/W5</b>	<b>W/m<sup>2</sup>K</b>	<b>2D* vs. T5/W5</b>	<b>W/m<sup>2</sup>K</b>	<b>3D vs 2D</b>
Frame sill	2.20	2.45	11%	2.45	11%	2.36	-3.7%
Frame head	2.20	2.00	-9%	1.97	-10%	1.97	-1.4%
Frame jamb	2.22	2.17	-2%	2.17	-2%	2.17	-0.1%
Center of glass	1.46	1.24	-15%	1.25	-15%	1.26	1.6%
Edge sill	2.08	2.85	37%	2.85	37%	2.89	1.4%
Edge head	2.08	1.33	-36%	1.36	-35%	1.45	9.5%
Edge jamb	2.09	1.88	-10%	1.88	-10%	1.97	4.7%
<b>TOTAL</b>	<b>1.80</b>	<b>1.66</b>	<b>-8%</b>	<b>1.66</b>	<b>-8%</b>	<b>1.68</b>	<b>1.7%</b>



**Table 6.5-3: Wood Window – Small Size, Highly Conducting Spacer (convection models)**

<b>Double Clear</b>	<b>Spacer Keff = 1.9 W/mK</b>						
<b>Section</b>	<b>T5/W5</b>	<b>2d</b>	<b>% diff</b>	<b>2D*</b>	<b>% diff</b>	<b>3d-overal</b>	<b>% diff</b>
	<b>W/m<sup>2</sup>K</b>	<b>W/m<sup>2</sup>K</b>	<b>2D vs. T5/W5</b>	<b>W/m<sup>2</sup>K</b>	<b>2D* vs. T5/W5</b>	<b>W/m<sup>2</sup>K</b>	<b>3D vs 2D</b>
Frame_sill	2.53	2.65	4%	2.65	4%	2.54	-3.9%
Frame_head	2.53	2.31	-9%	2.28	-10%	2.25	-2.6%
Frame_jamb	2.55	2.43	-5%	2.43	-5%	2.42	-0.6%
Center of glass	2.77	2.67	-3%	2.67	-3%	2.68	0.2%
Edge_sill	3.18	3.66	15%	3.66	15%	3.68	0.6%
Edge_head	3.18	2.67	-16%	2.68	-16%	2.74	2.6%
Edge_jamb	3.18	3.02	-5%	3.02	-5%	3.08	2.0%
<b>TOTAL</b>	<b>2.83</b>	<b>2.74</b>	<b>-3%</b>	<b>2.74</b>	<b>-3%</b>	<b>2.74</b>	<b>0.3%</b>
<b>Double Low-e HC</b>	<b>Spacer Keff = 1.9 W/mK</b>						
<b>Section</b>	<b>T5/W5</b>	<b>2d</b>	<b>% diff</b>	<b>2D*</b>	<b>% diff</b>	<b>3d-overal</b>	<b>% diff</b>
	<b>W/m<sup>2</sup>K</b>	<b>W/m<sup>2</sup>K</b>	<b>2D vs. T5/W5</b>	<b>W/m<sup>2</sup>K</b>	<b>2D* vs. T5/W5</b>	<b>W/m<sup>2</sup>K</b>	<b>3D vs 2D</b>
Frame_sill	2.42	2.62	8%	2.62	8%	2.51	-3.9%
Frame_head	2.42	2.25	-7%	2.22	-9%	2.19	-2.4%
Frame_jamb	2.44	2.38	-2%	2.38	-2%	2.37	-0.5%
Center of glass	1.72	1.54	-11%	1.55	-10%	1.56	1.2%
Edge_sill	2.42	3.08	27%	3.08	27%	3.13	1.5%
Edge_head	2.42	1.75	-28%	1.78	-26%	1.88	7.0%
Edge_jamb	2.43	2.24	-8%	2.24	-8%	2.32	3.6%
<b>TOTAL</b>	<b>2.08</b>	<b>1.95</b>	<b>-6%</b>	<b>1.95</b>	<b>-6%</b>	<b>1.97</b>	<b>1.2%</b>
<b>Double Low-e sC</b>	<b>Spacer Keff = 1.9 W/mK</b>						
<b>Section</b>	<b>T5/W5</b>	<b>2d</b>	<b>% diff</b>	<b>2D*</b>	<b>% diff</b>	<b>3d-overal</b>	<b>% diff</b>
	<b>W/m<sup>2</sup>K</b>	<b>W/m<sup>2</sup>K</b>	<b>2D vs. T5/W5</b>	<b>W/m<sup>2</sup>K</b>	<b>2D* vs. T5/W5</b>	<b>W/m<sup>2</sup>K</b>	<b>3D vs 2D</b>
Frame_sill	2.41	2.62	9%	2.62	9%	2.52	-3.9%
Frame_head	2.41	2.22	-8%	2.19	-9%	2.17	-2.3%
Frame_jamb	2.43	2.37	-2%	2.37	-2%	2.36	-0.5%
Center of glass	1.46	1.24	-15%	1.26	-14%	1.27	2.0%
Edge_sill	2.25	2.98	33%	2.98	33%	3.03	1.7%
Edge_head	2.25	1.50	-33%	1.53	-32%	1.64	9.4%
Edge_jamb	2.25	2.05	-9%	2.05	-9%	2.13	4.2%
<b>TOTAL</b>	<b>1.90</b>	<b>1.75</b>	<b>-8%</b>	<b>1.75</b>	<b>-7%</b>	<b>1.77</b>	<b>1.6%</b>

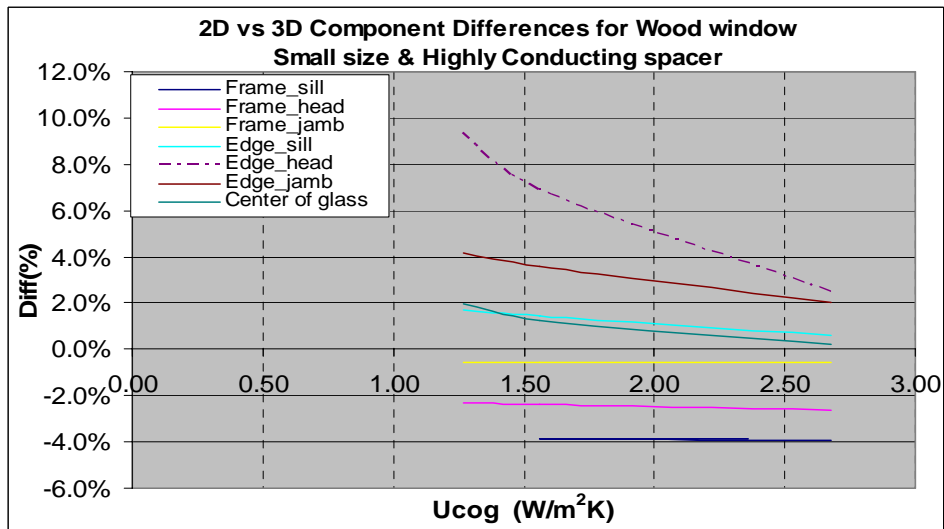
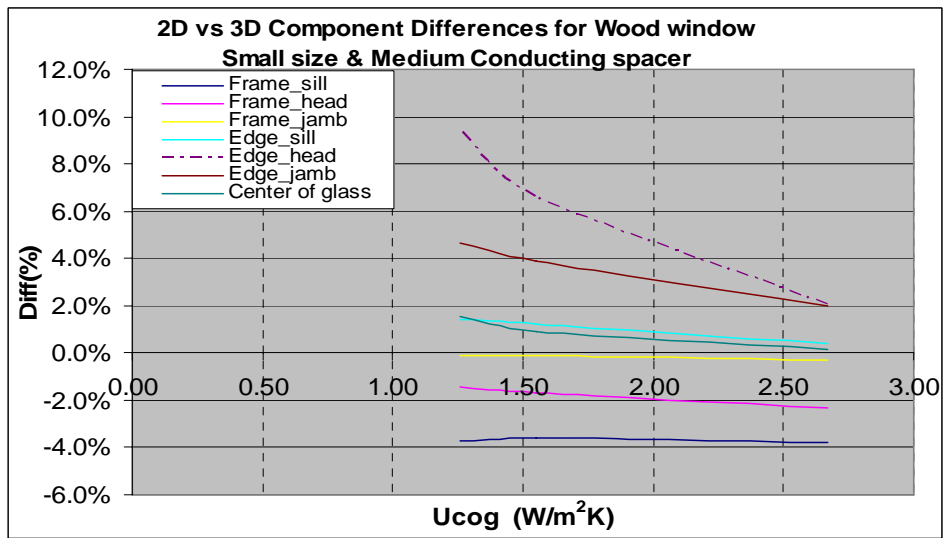
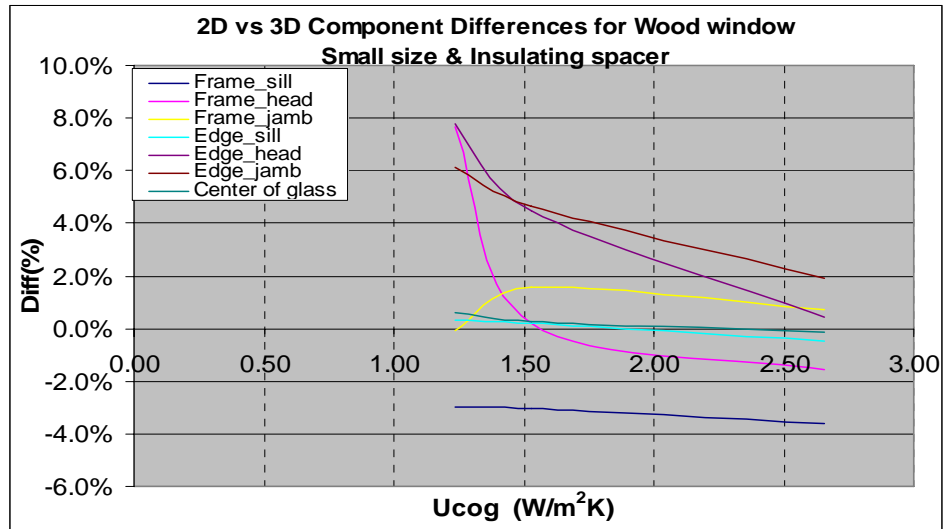

**Figure 6.5-1: Component Level Difference Graphs for Small Size Wood Window (convection models)**

**Table 6.5-4: Wood Window – Medium Size, Insulating Spacer (convection models)**

<b>Double Clear</b>	<b>Spacer Keff = 0.05 W/mK</b>						
<b>Section</b>	<b>T5/W5</b>	<b>2d</b>	<b>% diff</b>	<b>2D*</b>	<b>% diff</b>	<b>3d-overal</b>	<b>% diff</b>
	<b>W/m<sup>2</sup>K</b>	<b>W/m<sup>2</sup>K</b>	<b>2D vs. T5/W5</b>	<b>W/m<sup>2</sup>K</b>	<b>2D* vs. T5/W5</b>	<b>W/m<sup>2</sup>K</b>	<b>3D vs 2D</b>
Frame_sill	1.87	2.06	10%	2.06	10%	1.99	-3.5%
Frame_head	1.87	1.65	-12%	1.63	-13%	1.63	-1.6%
Frame_jamb	1.89	1.76	-7%	1.76	-7%	1.78	1.2%
Center of glass	2.77	2.67	-4%	2.66	-4%	2.66	-0.2%
Edge_sill	2.76	3.27	18%	3.26	18%	3.25	-0.5%
Edge_head	2.76	2.35	-15%	2.36	-15%	2.37	0.5%
Edge_jamb	2.77	2.62	-5%	2.62	-5%	2.65	1.0%
<b>TOTAL</b>	<b>2.59</b>	<b>2.49</b>	<b>-4%</b>	<b>2.49</b>	<b>-4%</b>	<b>2.49</b>	<b>0.0%</b>
<b>Double Low-e HC</b>	<b>Spacer Keff = 0.05 W/mK</b>						
<b>Section</b>	<b>T5/W5</b>	<b>2d</b>	<b>% diff</b>	<b>2D*</b>	<b>% diff</b>	<b>3d-overal</b>	<b>% diff</b>
	<b>W/m<sup>2</sup>K</b>	<b>W/m<sup>2</sup>K</b>	<b>2D vs. T5/W5</b>	<b>W/m<sup>2</sup>K</b>	<b>2D* vs. T5/W5</b>	<b>W/m<sup>2</sup>K</b>	<b>3D vs 2D</b>
Frame_sill	1.68	1.95	16%	1.94	16%	1.89	-3.0%
Frame_head	1.68	1.47	-12%	1.45	-14%	1.47	-0.1%
Frame_jamb	1.70	1.61	-5%	1.61	-5%	1.64	1.6%
Center of glass	1.72	1.57	-9%	1.56	-9%	1.56	-0.3%
Edge_sill	1.88	2.56	36%	2.55	36%	2.56	0.0%
Edge_head	1.88	1.39	-26%	1.40	-26%	1.44	3.3%
Edge_jamb	1.89	1.73	-9%	1.73	-9%	1.77	2.6%
<b>TOTAL</b>	<b>1.76</b>	<b>1.65</b>	<b>-6%</b>	<b>1.64</b>	<b>-7%</b>	<b>1.66</b>	<b>0.5%</b>
<b>Double Low-e sC</b>	<b>Spacer Keff = 0.05 W/mK</b>						
<b>Section</b>	<b>T5/W5</b>	<b>2d</b>	<b>% diff</b>	<b>2D*</b>	<b>% diff</b>	<b>3d-overal</b>	<b>% diff</b>
	<b>W/m<sup>2</sup>K</b>	<b>W/m<sup>2</sup>K</b>	<b>2D vs. T5/W5</b>	<b>W/m<sup>2</sup>K</b>	<b>2D* vs. T5/W5</b>	<b>W/m<sup>2</sup>K</b>	<b>3D vs 2D</b>
Frame_sill	1.63	1.93	18%	1.93	18%	1.88	-2.8%
Frame_head	1.63	1.42	-13%	1.40	-14%	1.42	0.4%
Frame_jamb	1.66	1.58	-5%	1.58	-5%	1.61	1.8%
Center of glass	1.46	1.27	-13%	1.27	-13%	1.27	-0.2%
Edge_sill	1.67	2.43	45%	2.43	45%	2.43	0.2%
Edge_head	1.67	1.12	-33%	1.13	-32%	1.18	5.2%
Edge_jamb	1.68	1.50	-11%	1.50	-11%	1.55	3.4%
<b>TOTAL</b>	<b>1.56</b>	<b>1.42</b>	<b>-8%</b>	<b>1.42</b>	<b>-9%</b>	<b>1.44</b>	<b>0.8%</b>

**Table 6.5-5: Wood Window – Medium Size, Medium conducting Spacer (convection models)**

<b>Double Clear</b>	<b>Spacer Keff = 0.6742 W/mK</b>						
<b>Section</b>	<b>T5/W5</b>	<b>2d</b>	<b>% diff</b>	<b>2D*</b>	<b>% diff</b>	<b>3d-overal</b>	<b>% diff</b>
	<b>W/m<sup>2</sup>K</b>	<b>W/m<sup>2</sup>K</b>	<b>2D vs. T5/W5</b>	<b>W/m<sup>2</sup>K</b>	<b>2D* vs. T5/W5</b>	<b>W/m<sup>2</sup>K</b>	<b>3D vs 2D</b>
Frame_sill	2.33	2.49	7%	2.48	7%	2.39	-3.8%
Frame_head	2.33	2.13	-8%	2.11	-10%	2.09	-2.3%
Frame_jamb	2.33	2.25	-3%	2.25	-3%	2.26	0.3%
Center of glass	2.77	2.67	-3%	2.67	-4%	2.67	0.0%
Edge_sill	3.05	3.51	15%	3.51	15%	3.52	0.4%
Edge_head	3.05	2.62	-14%	2.64	-13%	2.68	2.1%
Edge_jamb	3.05	2.92	-4%	2.92	-4%	2.96	1.2%
<b>TOTAL</b>	<b>2.76</b>	<b>2.67</b>	<b>-3%</b>	<b>2.67</b>	<b>-3%</b>	<b>2.67</b>	<b>0.1%</b>
<b>Double Low-e HC</b>	<b>Spacer Keff = 0.6742 W/mK</b>						
<b>Section</b>	<b>T5/W5</b>	<b>2d</b>	<b>% diff</b>	<b>2D*</b>	<b>% diff</b>	<b>3d-overal</b>	<b>% diff</b>
	<b>W/m<sup>2</sup>K</b>	<b>W/m<sup>2</sup>K</b>	<b>2D vs. T5/W5</b>	<b>W/m<sup>2</sup>K</b>	<b>2D* vs. T5/W5</b>	<b>W/m<sup>2</sup>K</b>	<b>3D vs 2D</b>
Frame_sill	2.23	2.44	9%	2.44	9%	2.35	-3.6%
Frame_head	2.23	2.05	-8%	2.02	-9%	2.01	-2.0%
Frame_jamb	2.25	2.19	-3%	2.19	-3%	2.20	0.5%
Center of glass	1.72	1.57	-9%	1.57	-9%	1.58	0.2%
Edge_sill	2.27	2.89	27%	2.89	27%	2.92	1.2%
Edge_head	2.27	1.76	-23%	1.77	-22%	1.85	5.4%
Edge_jamb	2.27	2.12	-7%	2.12	-7%	2.19	3.1%
<b>TOTAL</b>	<b>1.97</b>	<b>1.87</b>	<b>-5%</b>	<b>1.86</b>	<b>-6%</b>	<b>1.88</b>	<b>0.8%</b>
<b>Double Low-e sC</b>	<b>Spacer Keff = 0.6742 W/mK</b>						
<b>Section</b>	<b>T5/W5</b>	<b>2d</b>	<b>% diff</b>	<b>2D*</b>	<b>% diff</b>	<b>3d-overal</b>	<b>% diff</b>
	<b>W/m<sup>2</sup>K</b>	<b>W/m<sup>2</sup>K</b>	<b>2D vs. T5/W5</b>	<b>W/m<sup>2</sup>K</b>	<b>2D* vs. T5/W5</b>	<b>W/m<sup>2</sup>K</b>	<b>3D vs 2D</b>
Frame_sill	2.20	2.44	11%	2.44	11%	2.35	-3.6%
Frame_head	2.20	2.02	-8%	1.99	-9%	1.99	-1.6%
Frame_jamb	2.22	2.18	-2%	2.18	-2%	2.19	0.5%
Center of glass	1.46	1.28	-13%	1.27	-13%	1.28	0.5%
Edge_sill	2.08	2.77	33%	2.78	33%	2.81	1.4%
Edge_head	2.08	1.51	-27%	1.53	-26%	1.62	7.3%
Edge_jamb	2.09	1.92	-8%	1.92	-8%	1.99	3.9%
<b>TOTAL</b>	<b>1.78</b>	<b>1.65</b>	<b>-7%</b>	<b>1.65</b>	<b>-7%</b>	<b>1.67</b>	<b>1.1%</b>

**Table 6.5-6: Wood Window – Medium Size, Highly conducting Spacer (convection models)**

<b>Double Clear</b>	<b>Spacer Keff = 1.9 W/mK</b>						
<b>Section</b>	<b>T5/W5</b>	<b>2d</b>	<b>% diff</b>	<b>2D*</b>	<b>% diff</b>	<b>3d-overal</b>	<b>% diff</b>
	<b>W/m<sup>2</sup>K</b>	<b>W/m<sup>2</sup>K</b>	<b>2D vs. T5/W5</b>	<b>W/m<sup>2</sup>K</b>	<b>2D* vs. T5/W5</b>	<b>W/m<sup>2</sup>K</b>	<b>3D vs 2D</b>
Frame_sill	2.53	2.64	4%	2.64	4%	2.54	-3.7%
Frame_head	2.53	2.32	-8%	2.29	-9%	2.25	-3.2%
Frame_jamb	2.55	2.43	-5%	2.43	-5%	2.43	0.1%
Center of glass	2.77	2.67	-3%	2.67	-3%	2.67	0.0%
Edge_sill	3.18	3.61	13%	3.61	13%	3.63	0.6%
Edge_head	3.18	2.73	-14%	2.74	-14%	2.80	2.5%
Edge_jamb	3.18	3.04	-5%	3.04	-5%	3.08	1.3%
<b>TOTAL</b>	<b>2.83</b>	<b>2.74</b>	<b>-3%</b>	<b>2.73</b>	<b>-3%</b>	<b>2.74</b>	<b>0.1%</b>
<b>Double Low-e HC</b>	<b>Spacer Keff = 1.9 W/mK</b>						
<b>Section</b>	<b>T5/W5</b>	<b>2d</b>	<b>% diff</b>	<b>2D*</b>	<b>% diff</b>	<b>3d-overal</b>	<b>% diff</b>
	<b>W/m<sup>2</sup>K</b>	<b>W/m<sup>2</sup>K</b>	<b>2D vs. T5/W5</b>	<b>W/m<sup>2</sup>K</b>	<b>2D* vs. T5/W5</b>	<b>W/m<sup>2</sup>K</b>	<b>3D vs 2D</b>
Frame_sill	2.42	2.61	8%	2.61	8%	2.51	-3.8%
Frame_head	2.42	2.26	-7%	2.23	-8%	2.21	-2.5%
Frame_jamb	2.44	2.39	-2%	2.39	-2%	2.39	0.1%
Center of glass	1.72	1.58	-8%	1.57	-9%	1.58	0.5%
Edge_sill	2.42	3.02	24%	3.02	25%	3.06	1.5%
Edge_head	2.42	1.90	-22%	1.92	-21%	2.01	5.9%
Edge_jamb	2.43	2.28	-6%	2.28	-6%	2.34	2.7%
<b>TOTAL</b>	<b>2.05</b>	<b>1.95</b>	<b>-5%</b>	<b>1.95</b>	<b>-5%</b>	<b>1.96</b>	<b>0.8%</b>
<b>Double Low-e sC</b>	<b>Spacer Keff = 1.9 W/mK</b>						
<b>Section</b>	<b>T5/W5</b>	<b>2d</b>	<b>% diff</b>	<b>2D*</b>	<b>% diff</b>	<b>3d-overal</b>	<b>% diff</b>
	<b>W/m<sup>2</sup>K</b>	<b>W/m<sup>2</sup>K</b>	<b>2D vs. T5/W5</b>	<b>W/m<sup>2</sup>K</b>	<b>2D* vs. T5/W5</b>	<b>W/m<sup>2</sup>K</b>	<b>3D vs 2D</b>
Frame_sill	2.41	2.61	8%	2.61	9%	2.51	-3.8%
Frame_head	2.41	2.24	-7%	2.21	-8%	2.19	-2.3%
Frame_jamb	2.43	2.38	-2%	2.38	-2%	2.38	0.1%
Center of glass	1.46	1.28	-12%	1.28	-12%	1.29	0.9%
Edge_sill	2.25	2.91	29%	2.91	30%	2.96	1.8%
Edge_head	2.25	1.66	-26%	1.69	-25%	1.79	7.7%
Edge_jamb	2.25	2.08	-7%	2.08	-7%	2.15	3.3%
<b>TOTAL</b>	<b>1.86</b>	<b>1.74</b>	<b>-7%</b>	<b>1.74</b>	<b>-7%</b>	<b>1.76</b>	<b>1.1%</b>

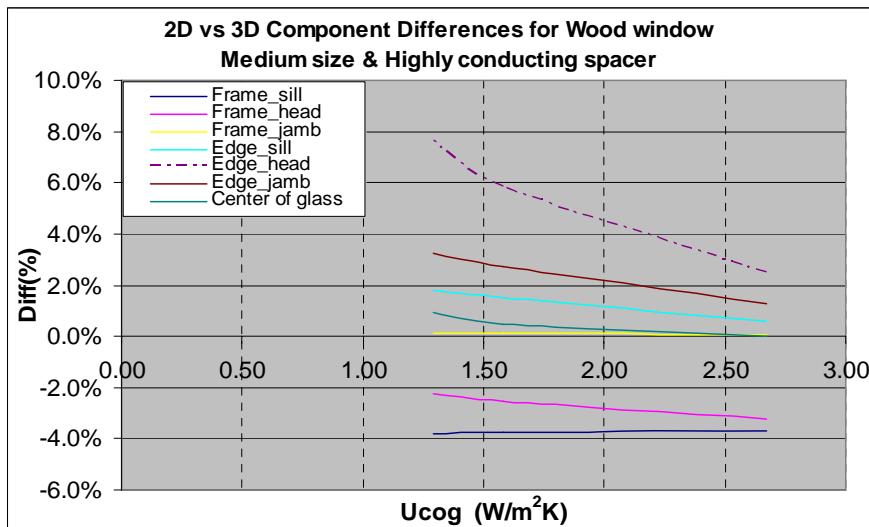
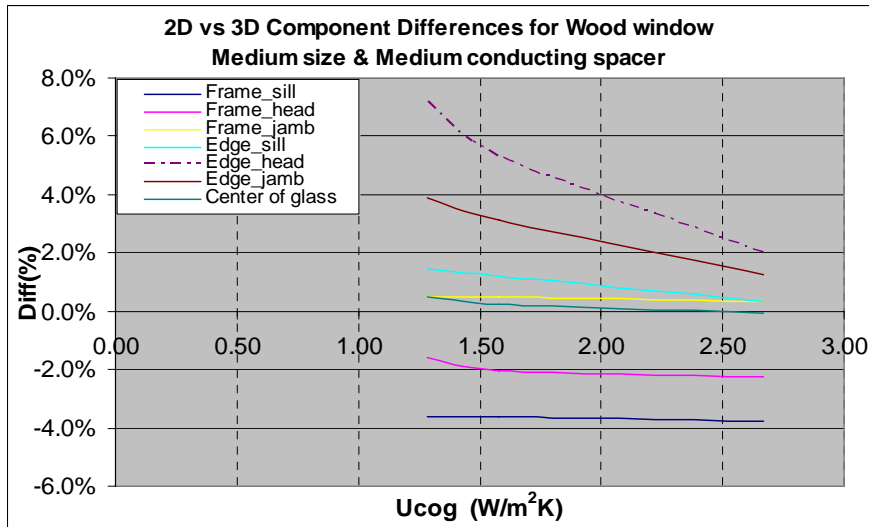
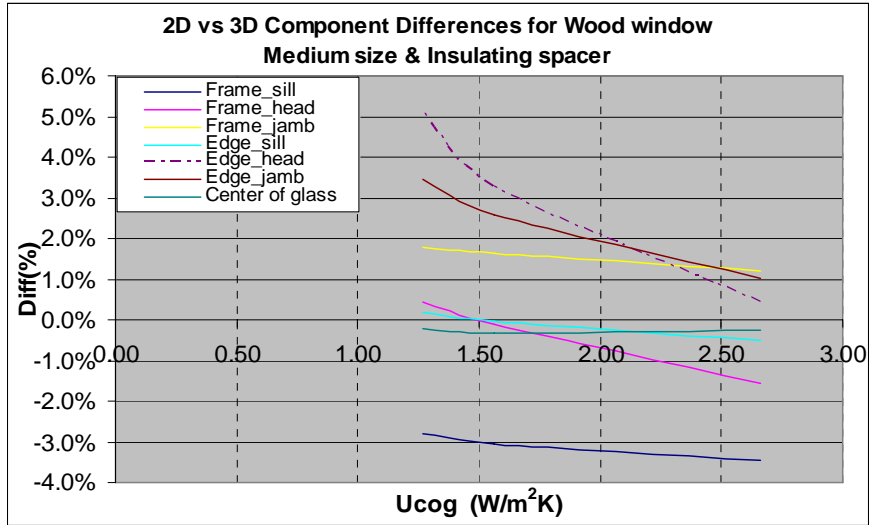

**Figure 6.5-2: Component Level Difference Graphs for Medium Size Wood Window (convection models)**

**Table 6.5-7: Wood Window – Large Size, Insulating Spacer (convection models)**

<b>Double Clear</b>		<b>Spacer Keff = 0.05 W/mK</b>						
<b>Section</b>	<b>T5/W5</b>	<b>2d</b>	<b>% diff</b>	<b>2D*</b>	<b>% diff</b>	<b>3d-overal</b>	<b>% diff</b>	
	<b>W/m<sup>2</sup>K</b>	<b>W/m<sup>2</sup>K</b>	<b>2D vs. T5/W5</b>	<b>W/m<sup>2</sup>K</b>	<b>2D* vs. T5/W5</b>	<b>W/m<sup>2</sup>K</b>	<b>3D vs 2D</b>	
Frame_sill	1.87	2.05	10%	2.07	11%	2.00	-2.7%	
Frame_head	1.87	1.66	-11%	1.62	-13%	1.62	-1.9%	
Frame_jamb	1.89	1.77	-6%	1.77	-6%	1.79	0.8%	
Center of glass	2.77	2.66	-4%	2.67	-3%	2.67	0.3%	
Edge_sill	2.76	3.26	18%	3.29	19%	3.29	0.7%	
Edge_head	2.76	2.36	-15%	2.35	-15%	2.36	0.1%	
Edge_jamb	2.77	2.63	-5%	2.63	-5%	2.66	1.0%	
<b>TOTAL</b>	<b>2.60</b>	<b>2.50</b>	<b>-4%</b>	<b>2.51</b>	<b>-3%</b>	<b>2.51</b>	<b>0.4%</b>	
<b>Double Low-e HC</b>		<b>Spacer Keff = 0.05 W/mK</b>						
<b>Section</b>	<b>T5/W5</b>	<b>2d</b>	<b>% diff</b>	<b>2D*</b>	<b>% diff</b>	<b>3d-overal</b>	<b>% diff</b>	
	<b>W/m<sup>2</sup>K</b>	<b>W/m<sup>2</sup>K</b>	<b>2D vs. T5/W5</b>	<b>W/m<sup>2</sup>K</b>	<b>2D* vs. T5/W5</b>	<b>W/m<sup>2</sup>K</b>	<b>3D vs 2D</b>	
Frame_sill	1.68	1.94	16%	1.94	16%	1.89	-2.7%	
Frame_head	1.68	1.48	-12%	1.45	-14%	1.47	-0.5%	
Frame_jamb	1.72	1.63	-5%	1.63	-5%	1.65	1.0%	
Center of glass	1.72	1.56	-9%	1.55	-10%	1.56	-0.3%	
Edge_sill	1.88	2.56	36%	2.57	36%	2.57	0.5%	
Edge_head	1.88	1.39	-26%	1.39	-26%	1.43	2.4%	
Edge_jamb	1.89	1.74	-8%	1.74	-8%	1.77	2.0%	
<b>TOTAL</b>	<b>1.76</b>	<b>1.64</b>	<b>-7%</b>	<b>1.64</b>	<b>-7%</b>	<b>1.65</b>	<b>0.4%</b>	
<b>Double Low-e sC</b>		<b>Spacer Keff = 0.05 W/mK</b>						
<b>Section</b>	<b>T5/W5</b>	<b>2d</b>	<b>% diff</b>	<b>2D*</b>	<b>% diff</b>	<b>3d-overal</b>	<b>% diff</b>	
	<b>W/m<sup>2</sup>K</b>	<b>W/m<sup>2</sup>K</b>	<b>2D vs. T5/W5</b>	<b>W/m<sup>2</sup>K</b>	<b>2D* vs. T5/W5</b>	<b>W/m<sup>2</sup>K</b>	<b>3D vs 2D</b>	
Frame_sill	1.63	1.93	18%	1.93	18%	1.88	-2.7%	
Frame_head	1.63	1.42	-13%	1.39	-15%	1.42	0.0%	
Frame_jamb	1.66	1.60	-4%	1.60	-4%	1.61	1.1%	
Center of glass	1.46	1.26	-14%	1.25	-14%	1.26	-0.3%	
Edge_sill	1.67	2.43	45%	2.44	46%	2.45	0.8%	
Edge_head	1.67	1.12	-33%	1.12	-33%	1.17	4.0%	
Edge_jamb	1.68	1.50	-11%	1.50	-11%	1.55	3.2%	
<b>TOTAL</b>	<b>1.55</b>	<b>1.41</b>	<b>-9%</b>	<b>1.41</b>	<b>-9%</b>	<b>1.42</b>	<b>0.7%</b>	

**Table 6.5-8: Wood Window – Large Size, Medium Conducting Spacer (convection models)**

<b>Double Clear</b>	<b>Spacer Keff = 0.6742 W/mK</b>						
<b>Section</b>	<b>T5/W5</b>	<b>2d</b>	<b>% diff</b>	<b>2D*</b>	<b>% diff</b>	<b>3d-overal</b>	<b>% diff</b>
	<b>W/m<sup>2</sup>K</b>	<b>W/m<sup>2</sup>K</b>	<b>2D vs. T5/W5</b>	<b>W/m<sup>2</sup>K</b>	<b>2D* vs. T5/W5</b>	<b>W/m<sup>2</sup>K</b>	<b>3D vs 2D</b>
Frame_sill	2.33	2.48	6%	2.49	7%	2.40	-3.3%
Frame_head	2.33	2.14	-8%	2.10	-10%	2.08	-2.8%
Frame_jamb	2.33	2.26	-3%	2.26	-3%	2.26	0.0%
Center of glass	2.77	2.67	-4%	2.67	-3%	2.68	0.4%
Edge_sill	3.05	3.51	15%	3.54	16%	3.56	1.3%
Edge_head	3.05	2.63	-14%	2.63	-14%	2.67	1.6%
Edge_jamb	3.05	2.93	-4%	2.93	-4%	2.96	0.9%
<b>TOTAL</b>	<b>2.76</b>	<b>2.67</b>	<b>-3%</b>	<b>2.67</b>	<b>-3%</b>	<b>2.68</b>	<b>0.4%</b>
<b>Double Low-e HC</b>	<b>Spacer Keff = 0.6742 W/mK</b>						
<b>Section</b>	<b>T5/W5</b>	<b>2d</b>	<b>% diff</b>	<b>2D*</b>	<b>% diff</b>	<b>3d-overal</b>	<b>% diff</b>
	<b>W/m<sup>2</sup>K</b>	<b>W/m<sup>2</sup>K</b>	<b>2D vs. T5/W5</b>	<b>W/m<sup>2</sup>K</b>	<b>2D* vs. T5/W5</b>	<b>W/m<sup>2</sup>K</b>	<b>3D vs 2D</b>
Frame_sill	2.23	2.43	9%	2.44	9%	2.35	-3.5%
Frame_head	2.23	2.06	-8%	2.02	-9%	2.01	-2.2%
Frame_jamb	2.25	2.20	-2%	2.20	-2%	2.20	0.0%
Center of glass	1.72	1.56	-9%	1.56	-9%	1.57	0.3%
Edge_sill	2.27	2.89	27%	2.91	28%	2.94	1.6%
Edge_head	2.27	1.76	-22%	1.76	-22%	1.84	4.6%
Edge_jamb	2.27	2.13	-6%	2.13	-6%	2.17	1.9%
<b>TOTAL</b>	<b>1.96</b>	<b>1.85</b>	<b>-6%</b>	<b>1.85</b>	<b>-6%</b>	<b>1.86</b>	<b>0.6%</b>
<b>Double Low-e sC</b>	<b>Spacer Keff = 0.6742 W/mK</b>						
<b>Section</b>	<b>T5/W5</b>	<b>2d</b>	<b>% diff</b>	<b>2D*</b>	<b>% diff</b>	<b>3d-overal</b>	<b>% diff</b>
	<b>W/m<sup>2</sup>K</b>	<b>W/m<sup>2</sup>K</b>	<b>2D vs. T5/W5</b>	<b>W/m<sup>2</sup>K</b>	<b>2D* vs. T5/W5</b>	<b>W/m<sup>2</sup>K</b>	<b>3D vs 2D</b>
Frame_sill	2.20	2.43	10%	2.44	11%	2.35	-3.5%
Frame_head	2.20	2.03	-8%	1.99	-9%	1.99	-2.0%
Frame_jamb	2.22	2.19	-2%	2.19	-2%	2.19	0.0%
Center of glass	1.46	1.27	-13%	1.26	-13%	1.27	0.6%
Edge_sill	2.08	2.78	33%	2.80	34%	2.83	1.8%
Edge_head	2.08	1.52	-27%	1.52	-27%	1.61	6.2%
Edge_jamb	2.09	1.92	-8%	1.92	-8%	1.97	2.5%
<b>TOTAL</b>	<b>1.76</b>	<b>1.63</b>	<b>-8%</b>	<b>1.63</b>	<b>-8%</b>	<b>1.64</b>	<b>0.9%</b>



**Table 6.5-9: Wood Window – Large Size, Highly Conducting Spacer (convection models)**

<b>Double Clear</b>	<b>Spacer Keff = 1.9 W/mK</b>						
<b>Section</b>	<b>T5/W5</b>	<b>2d</b>	<b>% diff</b>	<b>2D*</b>	<b>% diff</b>	<b>3d-overal</b>	<b>% diff</b>
	<b>W/m<sup>2</sup>K</b>	<b>W/m<sup>2</sup>K</b>	<b>2D vs. T5/W5</b>	<b>W/m<sup>2</sup>K</b>	<b>2D* vs. T5/W5</b>	<b>W/m<sup>2</sup>K</b>	<b>3D vs 2D</b>
Frame_sill	2.53	2.63	4%	2.64	4%	2.54	-3.6%
Frame_head	2.53	2.33	-8%	2.28	-10%	2.25	-3.1%
Frame_jamb	2.55	2.43	-5%	2.43	-5%	2.43	-0.2%
Center of glass	2.77	2.67	-4%	2.68	-3%	2.68	0.5%
Edge_sill	3.18	3.61	14%	3.64	15%	3.66	1.5%
Edge_head	3.18	2.73	-14%	2.73	-14%	2.79	2.1%
Edge_jamb	3.18	3.03	-5%	3.03	-5%	3.07	1.2%
<b>TOTAL</b>	<b>2.83</b>	<b>2.73</b>	<b>-4%</b>	<b>2.73</b>	<b>-3%</b>	<b>2.74</b>	<b>0.5%</b>
<b>Double Low-e HC</b>	<b>Spacer Keff = 1.9 W/mK</b>						
<b>Section</b>	<b>T5/W5</b>	<b>2d</b>	<b>% diff</b>	<b>2D*</b>	<b>% diff</b>	<b>3d-overal</b>	<b>% diff</b>
	<b>W/m<sup>2</sup>K</b>	<b>W/m<sup>2</sup>K</b>	<b>2D vs. T5/W5</b>	<b>W/m<sup>2</sup>K</b>	<b>2D* vs. T5/W5</b>	<b>W/m<sup>2</sup>K</b>	<b>3D vs 2D</b>
Frame_sill	2.42	2.60	7%	2.61	8%	2.51	-3.7%
Frame_head	2.42	2.27	-6%	2.23	-8%	2.21	-2.7%
Frame_jamb	2.44	2.40	-2%	2.40	-2%	2.39	-0.2%
Center of glass	1.72	1.57	-9%	1.57	-9%	1.58	0.6%
Edge_sill	2.42	3.02	25%	3.04	25%	3.07	1.8%
Edge_head	2.42	1.91	-21%	1.91	-21%	2.00	5.1%
Edge_jamb	2.43	2.27	-6%	2.27	-6%	2.31	2.0%
<b>TOTAL</b>	<b>2.04</b>	<b>1.92</b>	<b>-6%</b>	<b>1.92</b>	<b>-6%</b>	<b>1.93</b>	<b>0.7%</b>
<b>Double Low-e sC</b>	<b>Spacer Keff = 1.9 W/mK</b>						
<b>Section</b>	<b>T5/W5</b>	<b>2d</b>	<b>% diff</b>	<b>2D*</b>	<b>% diff</b>	<b>3d-overal</b>	<b>% diff</b>
	<b>W/m<sup>2</sup>K</b>	<b>W/m<sup>2</sup>K</b>	<b>2D vs. T5/W5</b>	<b>W/m<sup>2</sup>K</b>	<b>2D* vs. T5/W5</b>	<b>W/m<sup>2</sup>K</b>	<b>3D vs 2D</b>
Frame_sill	2.41	2.61	8%	2.61	9%	2.51	-3.8%
Frame_head	2.41	2.25	-6%	2.21	-8%	2.19	-2.7%
Frame_jamb	2.43	2.39	-2%	2.39	-2%	2.38	-0.2%
Center of glass	1.46	1.27	-13%	1.27	-13%	1.28	1.0%
Edge_sill	2.25	2.91	30%	2.94	31%	2.97	2.1%
Edge_head	2.25	1.67	-26%	1.68	-25%	1.78	6.6%
Edge_jamb	2.25	2.08	-8%	2.08	-8%	2.13	2.4%
<b>TOTAL</b>	<b>1.84</b>	<b>1.71</b>	<b>-7%</b>	<b>1.71</b>	<b>-7%</b>	<b>1.72</b>	<b>1.0%</b>

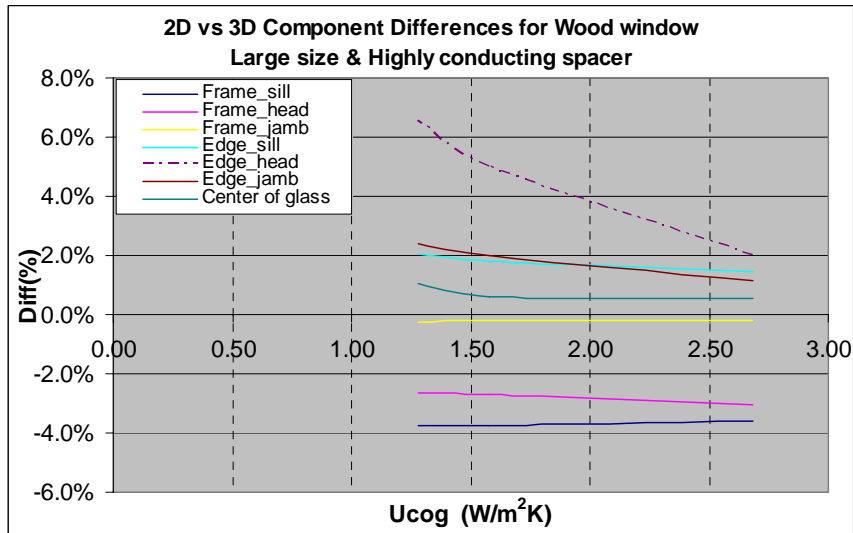
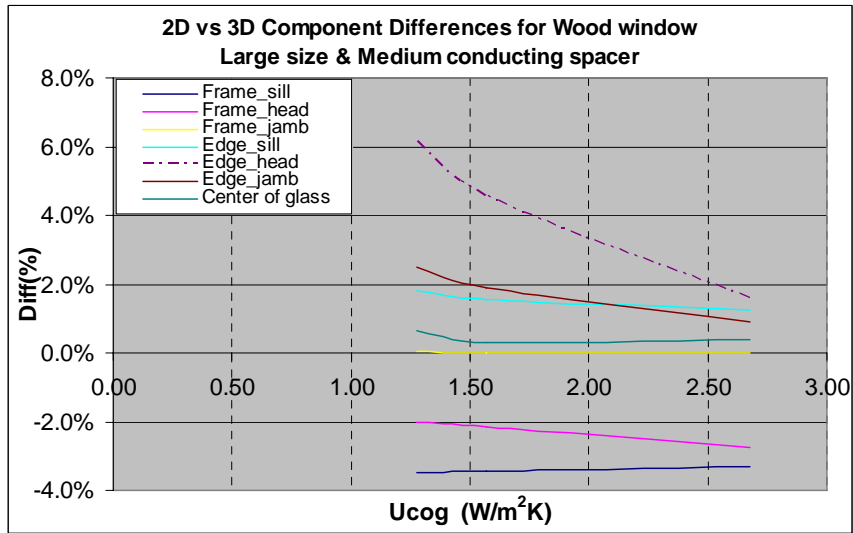
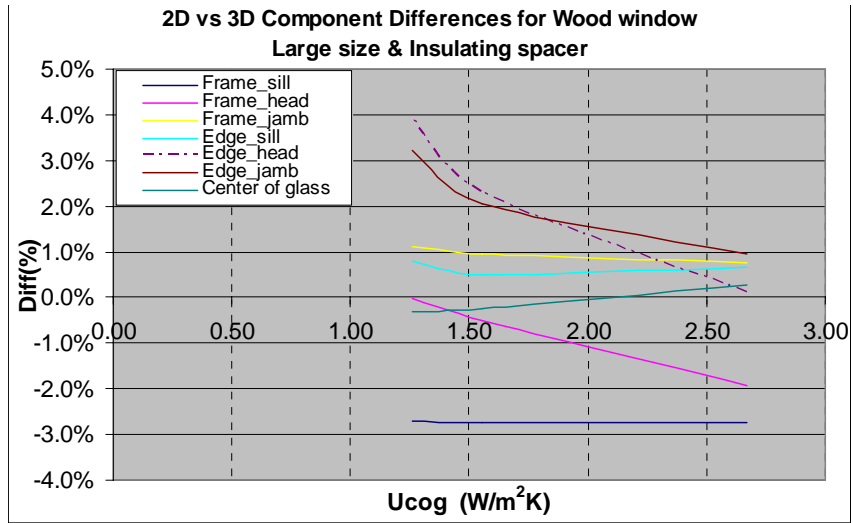

**Figure 6.5-3: Component Level Difference Graphs for Large Size Wood Window (convection models)**

## 6.5.2 Component level results and comparisons for T/B aluminum window (convection models)

**Table 6.5-10: T/B Al Window – Small Size, Insulating Spacer (convection models)**

<b>Double Clear</b>	<b>Spacer Keff = 0.05 W/mK</b>						
<b>Section</b>	<b>T5/W5</b>	<b>2d</b>	<b>% diff</b>	<b>2D*</b>	<b>% diff</b>	<b>3d-overal</b>	<b>% diff</b>
	<b>W/m<sup>2</sup>K</b>	<b>W/m<sup>2</sup>K</b>	<b>2D vs. T5/W5</b>	<b>W/m<sup>2</sup>K</b>	<b>2D* vs. T5/W5</b>	<b>W/m<sup>2</sup>K</b>	<b>3D vs 2D</b>
Frame_sill	5.02	5.07	1%	5.27	5%	5.09	0.2%
Frame_head	4.99	4.62	-7%	4.93	-1%	4.80	3.7%
Frame_jamb	5.38	5.10	-5%	5.10	-5%	5.10	0.0%
Center of glass	2.80	2.69	-4%	2.69	-4%	2.69	0.0%
Edge_sill	2.87	3.38	18%	3.38	18%	3.38	-0.2%
Edge_head	2.87	2.38	-17%	2.41	-16%	2.43	2.0%
Edge_jamb	2.90	2.74	-5%	2.74	-5%	2.79	1.8%
<b>TOTAL</b>	<b>3.57</b>	<b>3.43</b>	<b>-4%</b>	<b>3.46</b>	<b>-3%</b>	<b>3.45</b>	<b>0.6%</b>
<b>Double Low-e HC</b>	<b>Spacer Keff = 0.05 W/mK</b>						
<b>Section</b>	<b>T5/W5</b>	<b>2d</b>	<b>% diff</b>	<b>2D*</b>	<b>% diff</b>	<b>3d-overal</b>	<b>% diff</b>
	<b>W/m<sup>2</sup>K</b>	<b>W/m<sup>2</sup>K</b>	<b>2D vs. T5/W5</b>	<b>W/m<sup>2</sup>K</b>	<b>2D* vs. T5/W5</b>	<b>W/m<sup>2</sup>K</b>	<b>3D vs 2D</b>
Frame_sill	4.83	4.96	3%	5.16	7%	4.98	0.5%
Frame_head	4.83	4.44	-8%	4.77	-1%	4.64	4.6%
Frame_jamb	5.19	4.97	-4%	4.97	-4%	4.97	0.0%
Center of glass	1.73	1.54	-11%	1.55	-10%	1.55	0.8%
Edge_sill	2.00	2.68	34%	2.69	35%	2.69	0.5%
Edge_head	2.00	1.29	-35%	1.33	-34%	1.38	7.2%
Edge_jamb	2.03	1.80	-11%	1.80	-11%	1.88	4.2%
<b>TOTAL</b>	<b>2.83</b>	<b>2.65</b>	<b>-6%</b>	<b>2.69</b>	<b>-5%</b>	<b>2.69</b>	<b>1.4%</b>
<b>Double Low-e sC</b>	<b>Spacer Keff = 0.05 W/mK</b>						
<b>Section</b>	<b>T5/W5</b>	<b>2d</b>	<b>% diff</b>	<b>2D*</b>	<b>% diff</b>	<b>3d-overal</b>	<b>% diff</b>
	<b>W/m<sup>2</sup>K</b>	<b>W/m<sup>2</sup>K</b>	<b>2D vs. T5/W5</b>	<b>W/m<sup>2</sup>K</b>	<b>2D* vs. T5/W5</b>	<b>W/m<sup>2</sup>K</b>	<b>3D vs 2D</b>
Frame_sill	4.79	4.95	3%	5.14	7%	4.97	0.5%
Frame_head	4.79	4.39	-8%	4.73	-1%	4.61	5.1%
Frame_jamb	5.16	4.94	-4%	4.94	-4%	4.94	0.2%
Center of glass	1.47	1.23	-16%	1.24	-16%	1.24	0.7%
Edge_sill	1.79	2.55	43%	2.54	42%	2.56	0.4%
Edge_head	1.79	0.98	-45%	1.03	-42%	1.10	11.7%
Edge_jamb	1.82	1.56	-15%	1.56	-15%	1.64	5.5%
<b>TOTAL</b>	<b>2.65</b>	<b>2.45</b>	<b>-8%</b>	<b>2.49</b>	<b>-6%</b>	<b>2.49</b>	<b>1.6%</b>

**Table 6.5-11: T/B Al Window – Small Size, Medium Conducting Spacer (convection models)**

<b>Double Clear</b>	<b>Spacer Keff = 0.6742 W/mK</b>						
<b>Section</b>	<b>T5/W5</b>	<b>2d</b>	<b>% diff</b>	<b>2D*</b>	<b>% diff</b>	<b>3d-overal</b>	<b>% diff</b>
	<b>W/m<sup>2</sup>K</b>	<b>W/m<sup>2</sup>K</b>	<b>2D vs. T5/W5</b>	<b>W/m<sup>2</sup>K</b>	<b>2D* vs. T5/W5</b>	<b>W/m<sup>2</sup>K</b>	<b>3D vs 2D</b>
Frame_sill	5.35	5.42	1%	5.61	5%	5.41	-0.3%
Frame_head	5.35	5.01	-6%	5.30	-1%	5.14	2.6%
Frame_jamb	5.69	5.46	-4%	5.46	-4%	5.44	-0.3%
Center of glass	2.80	2.69	-4%	2.71	-3%	2.71	0.6%
Edge_sill	3.05	3.53	16%	3.55	16%	3.56	0.7%
Edge_head	3.05	2.55	-16%	2.55	-16%	2.59	1.5%
Edge_jamb	3.07	2.91	-5%	2.91	-5%	2.96	1.9%
<b>TOTAL</b>	<b>3.72</b>	<b>3.59</b>	<b>-3%</b>	<b>3.62</b>	<b>-3%</b>	<b>3.61</b>	<b>0.6%</b>
<b>Double Low-e HC</b>	<b>Spacer Keff = 0.6742 W/mK</b>						
<b>Section</b>	<b>T5/W5</b>	<b>2d</b>	<b>% diff</b>	<b>2D*</b>	<b>% diff</b>	<b>3d-overal</b>	<b>% diff</b>
	<b>W/m<sup>2</sup>K</b>	<b>W/m<sup>2</sup>K</b>	<b>2D vs. T5/W5</b>	<b>W/m<sup>2</sup>K</b>	<b>2D* vs. T5/W5</b>	<b>W/m<sup>2</sup>K</b>	<b>3D vs 2D</b>
Frame_sill	<b>5.22</b>	5.36	3%	5.55	6%	5.34	-0.3%
Frame_head	<b>5.23</b>	4.91	-6%	5.21	0%	5.06	2.9%
Frame_jamb	<b>5.57</b>	5.38	-3%	5.38	-3%	5.37	-0.2%
<b>Center of glass</b>	<b>1.73</b>	1.54	-11%	1.55	-10%	1.56	1.1%
Edge_sill	<b>2.25</b>	2.88	28%	2.88	28%	2.90	0.8%
Edge_head	<b>2.25</b>	1.54	-32%	1.57	-30%	1.65	7.1%
Edge_jamb	<b>2.26</b>	2.03	-10%	2.03	-10%	2.11	4.0%
<b>TOTAL</b>	<b>3.01</b>	<b>2.85</b>	<b>-6%</b>	<b>2.88</b>	<b>-4%</b>	<b>2.88</b>	<b>1.1%</b>
<b>Double Low-e sC</b>	<b>Spacer Keff = 0.6742 W/mK</b>						
<b>Section</b>	<b>T5/W5</b>	<b>2d</b>	<b>% diff</b>	<b>2D*</b>	<b>% diff</b>	<b>3d-overal</b>	<b>% diff</b>
	<b>W/m<sup>2</sup>K</b>	<b>W/m<sup>2</sup>K</b>	<b>2D vs. T5/W5</b>	<b>W/m<sup>2</sup>K</b>	<b>2D* vs. T5/W5</b>	<b>W/m<sup>2</sup>K</b>	<b>3D vs 2D</b>
Frame_sill	5.20	5.36	3%	5.54	7%	5.34	-0.3%
Frame_head	5.20	4.89	-6%	5.19	0%	5.03	3.0%
Frame_jamb	5.54	5.36	-3%	5.36	-3%	5.35	-0.2%
Center of glass	1.47	1.24	-15%	1.25	-15%	1.26	1.6%
Edge_sill	2.05	2.76	35%	2.76	34%	2.79	0.9%
Edge_head	2.05	1.26	-39%	1.29	-37%	1.38	10.1%
Edge_jamb	2.07	1.81	-12%	1.81	-12%	1.90	4.9%
<b>TOTAL</b>	<b>2.84</b>	<b>2.66</b>	<b>-7%</b>	<b>2.69</b>	<b>-5%</b>	<b>2.69</b>	<b>1.4%</b>

**Table 6.5-12: T/B Al Window – Small Size, Highly Conducting Spacer (convection models)**

<b>Double Clear</b>	<b>Spacer Keff = 1.9 W/mK</b>						
<b>Section</b>	<b>T5/W5</b>	<b>2d</b>	<b>% diff</b>	<b>2D*</b>	<b>% diff</b>	<b>3d-overal</b>	<b>% diff</b>
	<b>W/m<sup>2</sup>K</b>	<b>W/m<sup>2</sup>K</b>	<b>2D vs. T5/W5</b>	<b>W/m<sup>2</sup>K</b>	<b>2D* vs. T5/W5</b>	<b>W/m<sup>2</sup>K</b>	<b>3D vs 2D</b>
Frame_sill	5.52	5.58	1%	5.71	3%	5.50	-1.4%
Frame_head	5.51	5.19	-6%	5.41	-2%	5.24	0.9%
Frame_jamb	5.85	5.57	-5%	5.57	-5%	5.55	-0.4%
Center of glass	2.80	2.70	-4%	2.69	-4%	2.70	0.1%
Edge_sill	3.15	3.61	15%	3.62	15%	3.63	0.6%
Edge_head	3.14	2.63	-16%	2.65	-16%	2.70	2.7%
Edge_jamb	3.15	2.99	-5%	2.99	-5%	3.05	2.1%
<b>TOTAL</b>	<b>3.79</b>	<b>3.65</b>	<b>-4%</b>	<b>3.67</b>	<b>-3%</b>	<b>3.66</b>	<b>0.2%</b>
<b>Double Low-e HC</b>	<b>Spacer Keff = 1.9 W/mK</b>						
<b>Section</b>	<b>T5/W5</b>	<b>2d</b>	<b>% diff</b>	<b>2D*</b>	<b>% diff</b>	<b>3d-overal</b>	<b>% diff</b>
	<b>W/m<sup>2</sup>K</b>	<b>W/m<sup>2</sup>K</b>	<b>2D vs. T5/W5</b>	<b>W/m<sup>2</sup>K</b>	<b>2D* vs. T5/W5</b>	<b>W/m<sup>2</sup>K</b>	<b>3D vs 2D</b>
Frame_sill	5.42	5.53	2%	5.72	5%	5.51	-0.4%
Frame_head	5.41	5.13	-5%	5.41	0%	5.24	2.2%
Frame_jamb	5.76	5.57	-3%	5.57	-3%	5.55	-0.3%
Center of glass	1.73	1.55	-11%	1.56	-10%	1.57	1.2%
Edge_sill	2.37	2.98	26%	2.97	26%	3.00	0.9%
Edge_head	2.36	1.65	-30%	1.68	-29%	1.77	7.2%
Edge_jamb	2.38	2.14	-10%	2.14	-10%	2.22	3.6%
<b>TOTAL</b>	<b>3.10</b>	<b>2.93</b>	<b>-5%</b>	<b>2.97</b>	<b>-4%</b>	<b>2.96</b>	<b>1.0%</b>
<b>Double Low-e sC</b>	<b>Spacer Keff = 1.9 W/mK</b>						
<b>Section</b>	<b>T5/W5</b>	<b>2d</b>	<b>% diff</b>	<b>2D*</b>	<b>% diff</b>	<b>3d-overal</b>	<b>% diff</b>
	<b>W/m<sup>2</sup>K</b>	<b>W/m<sup>2</sup>K</b>	<b>2D vs. T5/W5</b>	<b>W/m<sup>2</sup>K</b>	<b>2D* vs. T5/W5</b>	<b>W/m<sup>2</sup>K</b>	<b>3D vs 2D</b>
Frame_sill	5.40	5.53	2%	5.71	6%	5.50	-0.5%
Frame_head	5.39	5.10	-5%	5.39	0%	5.22	2.3%
Frame_jamb	5.74	5.55	-3%	5.55	-3%	5.54	-0.3%
Center of glass	1.47	1.24	-15%	1.25	-15%	1.26	1.2%
Edge_sill	2.18	2.86	31%	2.85	31%	2.89	0.9%
Edge_head	2.18	1.38	-37%	1.41	-35%	1.52	9.9%
Edge_jamb	2.19	1.92	-12%	1.92	-12%	2.01	4.6%
<b>TOTAL</b>	<b>2.93</b>	<b>2.75</b>	<b>-6%</b>	<b>2.78</b>	<b>-5%</b>	<b>2.78</b>	<b>1.1%</b>

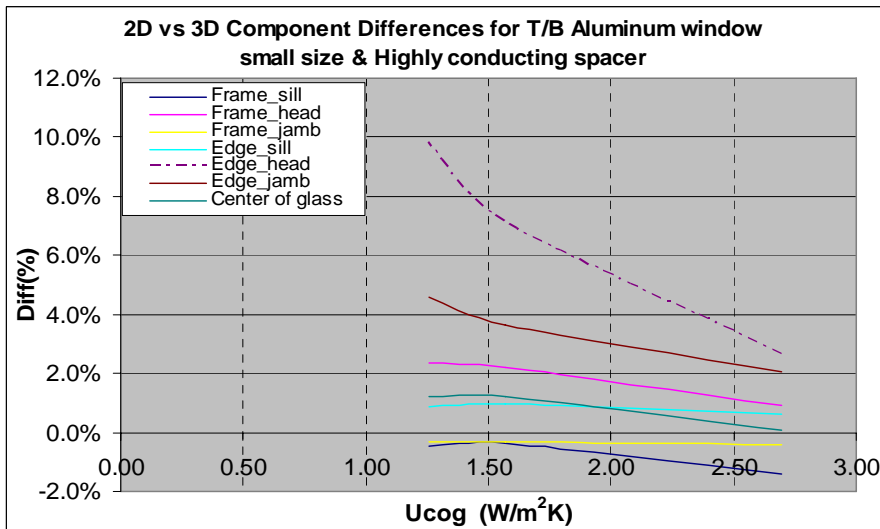
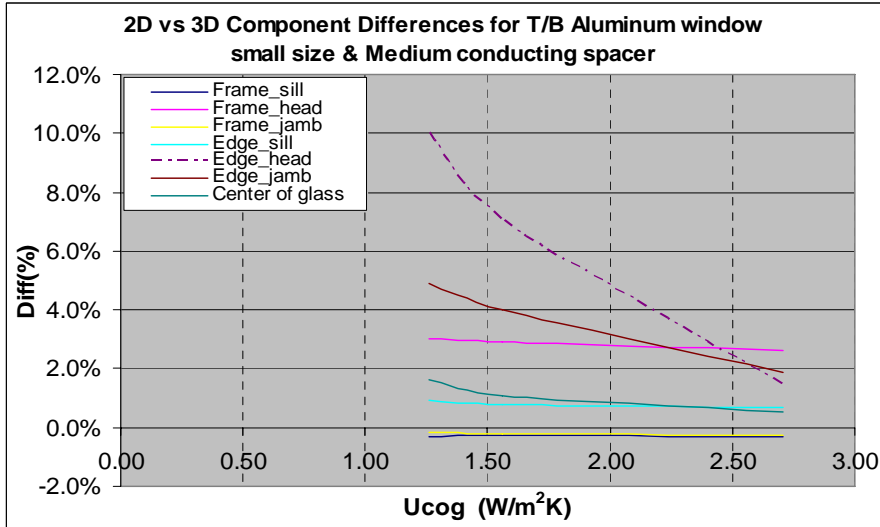
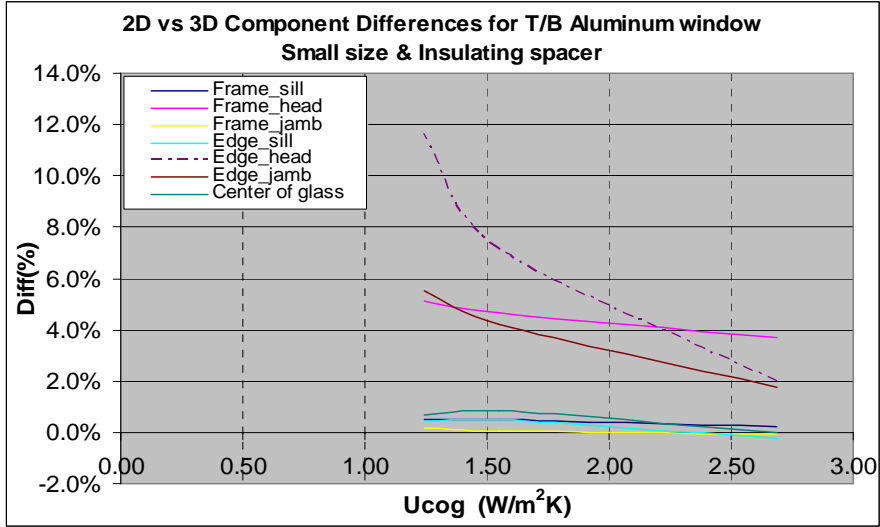

**Figure 6.5-4: Component Level Difference Graphs for small Size Thermally-broken Aluminum Window (convection models)**

### 6.5.3 Component level results and comparisons for aluminum window (convection models)

**Table 6.5-13: Aluminum Window – Small Size, Insulating Spacer (convection models)**

Double Clear		Spacer Keff = 0.05 W/mK						
Section	T5/W5	2d	% diff	2D*	% diff	3d-overal	% diff	
	W/m <sup>2</sup> K	W/m <sup>2</sup> K	2D vs. T5/W5	W/m <sup>2</sup> K	2D* vs. T5/W5	W/m <sup>2</sup> K	3D vs 2D	
Frame_sill	8.80	8.91	1%	9.01	2%	8.64	-3.1%	
Frame_head	8.80	8.57	-3%	8.75	-1%	8.41	-1.8%	
Frame_jamb	8.80	8.63	-2%	8.63	-2%	8.63	0.0%	
Center of glass	2.80	2.70	-4%	2.70	-3%	2.70	0.3%	
Edge_sill	3.08	3.62	18%	3.62	18%	3.63	0.3%	
Edge_head	3.08	2.61	-15%	2.63	-14%	2.68	2.9%	
Edge_jamb	3.08	2.98	-3%	2.98	-3%	3.04	2.1%	
<b>TOTAL</b>	<b>4.72</b>	<b>4.63</b>	<b>-2%</b>	<b>4.65</b>	<b>-2%</b>	<b>4.62</b>	<b>-0.2%</b>	
Double Low-e HC		Spacer Keff = 0.05 W/mK						
Section	T5/W5	2d	% diff	2D*	% diff	3d-overal	% diff	
	W/m <sup>2</sup> K	W/m <sup>2</sup> K	2D vs. T5/W5	W/m <sup>2</sup> K	2D* vs. T5/W5	W/m <sup>2</sup> K	3D vs 2D	
Frame_sill	8.72	8.86	2%	8.97	3%	8.60	-2.9%	
Frame_head	8.72	8.50	-2%	8.68	0%	8.36	-1.7%	
Frame_jamb	8.72	8.57	-2%	8.57	-2%	8.58	0.1%	
Center of glass	1.73	1.55	-11%	1.57	-10%	1.57	1.5%	
Edge_sill	2.24	2.96	32%	2.96	32%	3.00	1.2%	
Edge_head	2.24	1.61	-28%	1.63	-27%	1.72	6.7%	
Edge_jamb	2.25	2.10	-6%	2.10	-6%	2.19	4.3%	
<b>TOTAL</b>	<b>4.02</b>	<b>3.90</b>	<b>-3%</b>	<b>3.92</b>	<b>-3%</b>	<b>3.91</b>	<b>0.2%</b>	
Double Low-e sC		Spacer Keff = 0.05 W/mK						
Section	T5/W5	2d	% diff	2D*	% diff	3d-overal	% diff	
	W/m <sup>2</sup> K	W/m <sup>2</sup> K	2D vs. T5/W5	W/m <sup>2</sup> K	2D* vs. T5/W5	W/m <sup>2</sup> K	3D vs 2D	
Frame_sill	8.70	8.86	2%	8.97	3%	8.61	-2.8%	
Frame_head	8.70	8.47	-3%	8.66	0%	8.34	-1.6%	
Frame_jamb	8.70	8.57	-1%	8.57	-1%	8.58	0.1%	
Center of glass	1.47	1.25	-15%	1.26	-14%	1.27	1.7%	
Edge_sill	2.04	2.84	39%	2.86	40%	2.90	2.0%	
Edge_head	2.04	1.33	-35%	1.34	-34%	1.45	8.8%	
Edge_jamb	2.04	1.89	-8%	1.89	-8%	1.99	5.4%	
<b>TOTAL</b>	<b>3.85</b>	<b>3.71</b>	<b>-4%</b>	<b>3.74</b>	<b>-3%</b>	<b>3.72</b>	<b>0.3%</b>	

**Table 6.5-14: Aluminum Window – Small Size, Medium Conducting Spacer  
(convection models)**

<b>Double Clear</b>	<b>Spacer Keff = 0.6742 W/mK</b>						
<b>Section</b>	<b>T5/W5</b>	<b>2d</b>	<b>% diff</b>	<b>2D*</b>	<b>% diff</b>	<b>3d-overal</b>	<b>% diff</b>
	<b>W/m<sup>2</sup>K</b>	<b>W/m<sup>2</sup>K</b>	<b>2D vs. T5/W5</b>	<b>W/m<sup>2</sup>K</b>	<b>2D* vs. T5/W5</b>	<b>W/m<sup>2</sup>K</b>	<b>3D vs 2D</b>
Frame_sill	8.86	8.96	1%	9.05	2%	8.67	-3.2%
Frame_head	8.86	8.61	-3%	8.79	-1%	8.45	-1.8%
Frame_jamb	8.86	8.67	-2%	8.67	-2%	8.67	0.0%
Center of glass	2.80	2.70	-4%	2.70	-3%	2.71	0.3%
Edge_sill	3.19	3.69	16%	3.68	15%	3.70	0.3%
Edge_head	3.19	2.69	-16%	2.71	-15%	2.77	2.9%
Edge_jamb	3.19	3.06	-4%	3.06	-4%	3.12	2.1%
<b>TOTAL</b>	<b>4.77</b>	<b>4.67</b>	<b>-2%</b>	<b>4.69</b>	<b>-2%</b>	<b>4.66</b>	<b>-0.2%</b>
<b>Double Low-e HC</b>	<b>Spacer Keff = 0.6742 W/mK</b>						
<b>Section</b>	<b>T5/W5</b>	<b>2d</b>	<b>% diff</b>	<b>2D*</b>	<b>% diff</b>	<b>3d-overal</b>	<b>% diff</b>
	<b>W/m<sup>2</sup>K</b>	<b>W/m<sup>2</sup>K</b>	<b>2D vs. T5/W5</b>	<b>W/m<sup>2</sup>K</b>	<b>2D* vs. T5/W5</b>	<b>W/m<sup>2</sup>K</b>	<b>3D vs 2D</b>
Frame_sill	<b>8.79</b>	8.92	1%	9.02	3%	8.65	-3.0%
Frame_head	<b>8.79</b>	8.57	-3%	8.74	-1%	8.41	-1.9%
Frame_jamb	<b>8.80</b>	8.63	-2%	8.63	-2%	8.63	0.0%
<b>Center of glass</b>	<b>1.73</b>	1.55	-10%	1.57	-10%	1.57	1.4%
Edge_sill	<b>2.41</b>	3.06	27%	3.05	27%	3.09	1.1%
Edge_head	<b>2.41</b>	1.74	-28%	1.75	-27%	1.85	6.8%
Edge_jamb	<b>2.41</b>	2.21	-8%	2.21	-8%	2.30	4.0%
<b>TOTAL</b>	<b>4.09</b>	<b>3.95</b>	<b>-4%</b>	<b>3.97</b>	<b>-3%</b>	<b>3.95</b>	<b>0.1%</b>
<b>Double Low-e sC</b>	<b>Spacer Keff = 0.6742 W/mK</b>						
<b>Section</b>	<b>T5/W5</b>	<b>2d</b>	<b>% diff</b>	<b>2D*</b>	<b>% diff</b>	<b>3d-overal</b>	<b>% diff</b>
	<b>W/m<sup>2</sup>K</b>	<b>W/m<sup>2</sup>K</b>	<b>2D vs. T5/W5</b>	<b>W/m<sup>2</sup>K</b>	<b>2D* vs. T5/W5</b>	<b>W/m<sup>2</sup>K</b>	<b>3D vs 2D</b>
Frame_sill	8.78	8.93	2%	9.02	3%	8.65	-3.1%
Frame_head	8.78	8.55	-3%	8.72	-1%	8.39	-1.8%
Frame_jamb	8.78	8.63	-2%	8.63	-2%	8.63	0.0%
Center of glass	1.47	1.25	-15%	1.27	-14%	1.28	2.1%
Edge_sill	2.22	2.94	33%	2.93	32%	2.98	1.3%
Edge_head	2.22	1.46	-34%	1.48	-33%	1.60	9.0%
Edge_jamb	2.22	2.00	-10%	2.00	-10%	2.10	4.8%
<b>TOTAL</b>	<b>3.92</b>	<b>3.76</b>	<b>-4%</b>	<b>3.79</b>	<b>-4%</b>	<b>3.77</b>	<b>0.2%</b>



**Table 6.5-15: Aluminum Window – Small Size, Highly Conducting Spacer  
(convection models)**

<b>Double Clear</b>	<b>Spacer Keff = 1.9 W/mK</b>						
<b>Section</b>	<b>T5/W5</b>	<b>2d</b>	<b>% diff</b>	<b>2D*</b>	<b>% diff</b>	<b>3d-overal</b>	<b>% diff</b>
	<b>W/m<sup>2</sup>K</b>	<b>W/m<sup>2</sup>K</b>	<b>2D vs. T5/W5</b>	<b>W/m<sup>2</sup>K</b>	<b>2D* vs. T5/W5</b>	<b>W/m<sup>2</sup>K</b>	<b>3D vs 2D</b>
Frame_sill	8.89	8.98	1%	9.07	2%	8.69	-3.2%
Frame_head	8.89	8.64	-3%	8.82	-1%	8.48	-1.9%
Frame_jamb	8.89	8.70	-2%	8.70	-2%	8.70	-0.1%
Center of glass	2.80	2.70	-3%	2.71	-3%	2.71	0.4%
Edge_sill	3.25	3.72	15%	3.71	14%	3.73	0.3%
Edge_head	3.25	2.73	-16%	2.75	-15%	2.82	3.0%
Edge_jamb	3.25	3.10	-5%	3.10	-5%	3.16	2.1%
<b>TOTAL</b>	<b>4.80</b>	<b>4.69</b>	<b>-2%</b>	<b>4.70</b>	<b>-2%</b>	<b>4.68</b>	<b>-0.2%</b>
<b>Double Low-e HC</b>	<b>Spacer Keff = 1.9 W/mK</b>						
<b>Section</b>	<b>T5/W5</b>	<b>2d</b>	<b>% diff</b>	<b>2D*</b>	<b>% diff</b>	<b>3d-overal</b>	<b>% diff</b>
	<b>W/m<sup>2</sup>K</b>	<b>W/m<sup>2</sup>K</b>	<b>2D vs. T5/W5</b>	<b>W/m<sup>2</sup>K</b>	<b>2D* vs. T5/W5</b>	<b>W/m<sup>2</sup>K</b>	<b>3D vs 2D</b>
Frame_sill	8.83	8.95	1%	9.04	2%	8.67	-3.1%
Frame_head	8.83	8.61	-3%	8.77	-1%	8.43	-2.0%
Frame_jamb	8.83	8.66	-2%	8.66	-2%	8.66	0.0%
Center of glass	1.73	1.55	-10%	1.57	-9%	1.58	1.6%
Edge_sill	2.48	3.10	25%	3.09	25%	3.14	1.1%
Edge_head	2.48	1.80	-27%	1.81	-27%	1.92	6.7%
Edge_jamb	2.48	2.28	-8%	2.28	-8%	2.36	3.4%
<b>TOTAL</b>	<b>4.12</b>	<b>3.97</b>	<b>-4%</b>	<b>4.00</b>	<b>-3%</b>	<b>3.98</b>	<b>0.0%</b>
<b>Double Low-e sC</b>	<b>Spacer Keff = 1.9 W/mK</b>						
<b>Section</b>	<b>T5/W5</b>	<b>2d</b>	<b>% diff</b>	<b>2D*</b>	<b>% diff</b>	<b>3d-overal</b>	<b>% diff</b>
	<b>W/m<sup>2</sup>K</b>	<b>W/m<sup>2</sup>K</b>	<b>2D vs. T5/W5</b>	<b>W/m<sup>2</sup>K</b>	<b>2D* vs. T5/W5</b>	<b>W/m<sup>2</sup>K</b>	<b>3D vs 2D</b>
Frame_sill	8.82	8.95	2%	9.05	3%	8.67	-3.1%
Frame_head	8.82	8.58	-3%	8.75	-1%	8.42	-1.9%
Frame_jamb	8.82	8.66	-2%	8.66	-2%	8.65	0.0%
Center of glass	1.47	1.25	-15%	1.27	-14%	1.28	2.5%
Edge_sill	2.30	2.99	30%	2.98	30%	3.03	1.4%
Edge_head	2.30	1.52	-34%	1.55	-32%	1.67	9.4%
Edge_jamb	2.30	2.07	-10%	2.07	-10%	2.16	4.4%
<b>TOTAL</b>	<b>3.96</b>	<b>3.79</b>	<b>-4%</b>	<b>3.81</b>	<b>-4%</b>	<b>3.80</b>	<b>0.2%</b>

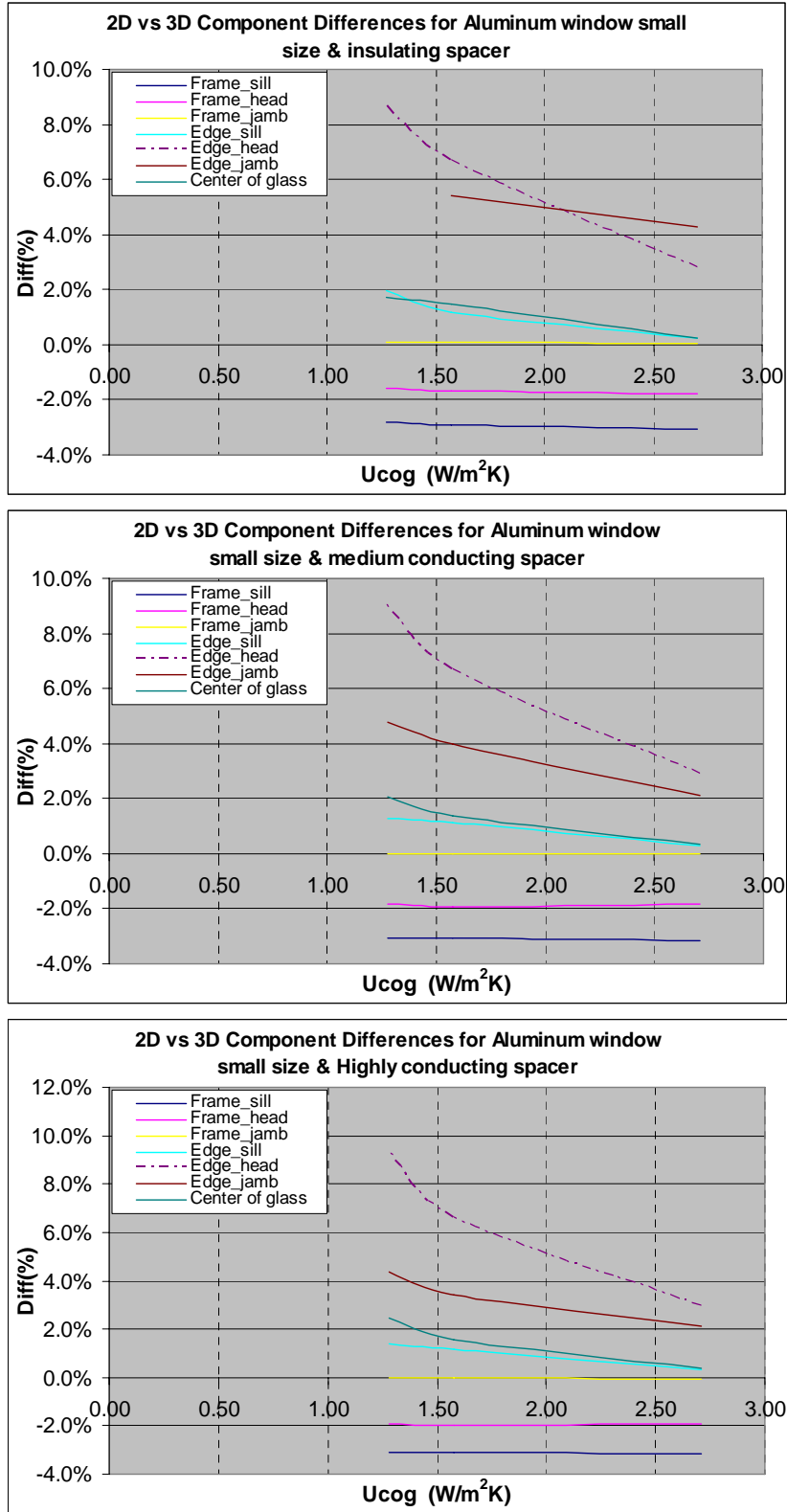

Figure 6.5-5: Component Level Difference Graphs for small Size Aluminum Window (convection models)

#### 6.5.4 Component level results and comparisons for PVC window (convection models)

Table 6.5-16: PVC Window – Small Size, Insulating Spacer (convection models)

<b>Double Clear</b>	<b>Spacer Keff = 0.05 W/mK</b>						
<b>Section</b>	<b>T5/W5</b>	<b>2d</b>	<b>% diff</b>	<b>2D*</b>	<b>% diff</b>	<b>3d-overal</b>	<b>% diff</b>
	<b>W/m<sup>2</sup>K</b>	<b>W/m<sup>2</sup>K</b>	<b>2D vs. T5/W5</b>	<b>W/m<sup>2</sup>K</b>	<b>2D* vs. T5/W5</b>	<b>W/m<sup>2</sup>K</b>	<b>3D vs 2D</b>
Frame_sill	2.11	2.25	7%	2.26	7%	2.21	-1.6%
Frame_head	2.11	1.86	-12%	1.87	-11%	1.87	0.7%
Frame_jamb	2.33	2.14	-8%	2.14	-8%	2.20	2.8%
Center of glass	2.80	2.69	-4%	2.69	-4%	2.69	-0.1%
Edge_sill	2.82	3.39	20%	3.38	20%	3.37	-0.6%
Edge_head	2.82	2.34	-17%	2.35	-17%	2.36	0.7%
Edge_jamb	2.83	2.68	-5%	2.68	-5%	2.73	1.9%
<b>TOTAL</b>	<b>2.63</b>	<b>2.53</b>	<b>-4%</b>	<b>2.53</b>	<b>-4%</b>	<b>2.54</b>	<b>0.7%</b>
<b>Double Low-e HC</b>	<b>Spacer Keff = 0.05 W/mK</b>						
<b>Section</b>	<b>T5/W5</b>	<b>2d</b>	<b>% diff</b>	<b>2D*</b>	<b>% diff</b>	<b>3d-overal</b>	<b>% diff</b>
	<b>W/m<sup>2</sup>K</b>	<b>W/m<sup>2</sup>K</b>	<b>2D vs. T5/W5</b>	<b>W/m<sup>2</sup>K</b>	<b>2D* vs. T5/W5</b>	<b>W/m<sup>2</sup>K</b>	<b>3D vs 2D</b>
Frame_sill	1.93	2.13	11%	2.14	11%	2.11	-0.9%
Frame_head	1.93	1.68	-13%	1.69	-12%	1.72	2.6%
Frame_jamb	2.15	1.99	-7%	1.99	-7%	2.07	3.8%
Center of glass	1.73	1.54	-11%	1.54	-11%	1.55	0.6%
Edge_sill	1.91	2.66	39%	2.65	39%	2.66	-0.3%
Edge_head	1.91	1.22	-36%	1.23	-36%	1.28	5.0%
Edge_jamb	1.93	1.71	-12%	1.71	-12%	1.79	4.7%
<b>TOTAL</b>	<b>1.89</b>	<b>1.73</b>	<b>-8%</b>	<b>1.74</b>	<b>-8%</b>	<b>1.77</b>	<b>2.0%</b>
<b>Double Low-e sC</b>	<b>Spacer Keff = 0.05 W/mK</b>						
<b>Section</b>	<b>T5/W5</b>	<b>2d</b>	<b>% diff</b>	<b>2D*</b>	<b>% diff</b>	<b>3d-overal</b>	<b>% diff</b>
	<b>W/m<sup>2</sup>K</b>	<b>W/m<sup>2</sup>K</b>	<b>2D vs. T5/W5</b>	<b>W/m<sup>2</sup>K</b>	<b>2D* vs. T5/W5</b>	<b>W/m<sup>2</sup>K</b>	<b>3D vs 2D</b>
Frame_sill	1.88	2.12	12%	2.13	13%	2.10	-0.9%
Frame_head	1.88	1.62	-14%	1.65	-13%	1.68	3.7%
Frame_jamb	2.10	1.95	-7%	1.95	-7%	2.03	4.0%
Center of glass	1.47	1.23	-16%	1.24	-16%	1.24	0.7%
Edge_sill	1.69	2.53	49%	2.50	48%	2.51	-0.7%
Edge_head	1.69	0.90	-47%	0.92	-46%	0.98	8.7%
Edge_jamb	1.72	1.46	-15%	1.46	-15%	1.55	5.8%
<b>TOTAL</b>	<b>1.70</b>	<b>1.53</b>	<b>-10%</b>	<b>1.53</b>	<b>-10%</b>	<b>1.57</b>	<b>2.4%</b>

**Table 6.5-17: PVC Window – Small Size, Medium Conducting Spacer (convection models)**

<b>Double Clear</b>	<b>Spacer Keff = 0.6742 W/mK</b>						
<b>Section</b>	<b>T5/W5</b>	<b>2d</b>	<b>% diff</b>	<b>2D*</b>	<b>% diff</b>	<b>3d-overal</b>	<b>% diff</b>
	<b>W/m<sup>2</sup>K</b>	<b>W/m<sup>2</sup>K</b>	<b>2D vs. T5/W5</b>	<b>W/m<sup>2</sup>K</b>	<b>2D* vs. T5/W5</b>	<b>W/m<sup>2</sup>K</b>	<b>3D vs 2D</b>
Frame_sill	2.50	2.58	3%	2.60	4%	2.52	-2.1%
Frame_head	2.50	2.24	-10%	2.25	-10%	2.22	-0.8%
Frame_jamb	2.71	2.53	-7%	2.53	-7%	2.57	1.6%
Center of glass	2.80	2.69	-4%	2.69	-4%	2.70	0.1%
Edge_sill	3.05	3.58	17%	3.57	17%	3.58	0.1%
Edge_head	3.05	2.55	-16%	2.55	-16%	2.59	1.8%
Edge_jamb	3.04	2.90	-5%	2.90	-5%	2.96	2.1%
<b>TOTAL</b>	<b>2.81</b>	<b>2.70</b>	<b>-4%</b>	<b>2.70</b>	<b>-4%</b>	<b>2.72</b>	<b>0.6%</b>
<b>Double Low-e HC</b>	<b>Spacer Keff = 0.6742 W/mK</b>						
<b>Section</b>	<b>T5/W5</b>	<b>2d</b>	<b>% diff</b>	<b>2D*</b>	<b>% diff</b>	<b>3d-overal</b>	<b>% diff</b>
	<b>W/m<sup>2</sup>K</b>	<b>W/m<sup>2</sup>K</b>	<b>2D vs. T5/W5</b>	<b>W/m<sup>2</sup>K</b>	<b>2D* vs. T5/W5</b>	<b>W/m<sup>2</sup>K</b>	<b>3D vs 2D</b>
Frame_sill	<b>2.40</b>	2.51	5%	2.54	6%	2.47	-1.7%
Frame_head	<b>2.40</b>	2.16	-10%	2.16	-10%	2.15	-0.4%
Frame_jamb	<b>2.61</b>	2.46	-6%	2.46	-6%	2.50	1.9%
<b>Center of glass</b>	<b>1.73</b>	1.54	-11%	1.56	-10%	1.56	1.1%
Edge_sill	<b>2.23</b>	2.92	31%	2.91	31%	2.94	0.8%
Edge_head	<b>2.23</b>	1.52	-32%	1.52	-32%	1.60	5.3%
Edge_jamb	<b>2.23</b>	2.01	-10%	2.01	-10%	2.10	4.7%
<b>TOTAL</b>	<b>2.11</b>	<b>1.96</b>	<b>-7%</b>	<b>1.96</b>	<b>-7%</b>	<b>1.99</b>	<b>1.7%</b>
<b>Double Low-e sC</b>	<b>Spacer Keff = 0.6742 W/mK</b>						
<b>Section</b>	<b>T5/W5</b>	<b>2d</b>	<b>% diff</b>	<b>2D*</b>	<b>% diff</b>	<b>3d-overal</b>	<b>% diff</b>
	<b>W/m<sup>2</sup>K</b>	<b>W/m<sup>2</sup>K</b>	<b>2D vs. T5/W5</b>	<b>W/m<sup>2</sup>K</b>	<b>2D* vs. T5/W5</b>	<b>W/m<sup>2</sup>K</b>	<b>3D vs 2D</b>
Frame_sill	2.37	2.51	6%	2.53	7%	2.47	-1.8%
Frame_head	2.37	2.13	-10%	2.15	-10%	2.13	0.2%
Frame_jamb	2.58	2.44	-6%	2.44	-6%	2.49	1.9%
Center of glass	1.47	1.24	-15%	1.25	-15%	1.26	1.5%
Edge_sill	2.03	2.80	38%	2.78	37%	2.81	0.5%
Edge_head	2.03	1.24	-39%	1.25	-38%	1.34	8.3%
Edge_jamb	2.03	1.79	-12%	1.79	-12%	1.88	5.3%
<b>TOTAL</b>	<b>1.94</b>	<b>1.77</b>	<b>-9%</b>	<b>1.77</b>	<b>-8%</b>	<b>1.80</b>	<b>2.0%</b>

**Table 6.5-18: PVC Window – Small Size, Highly Conducting Spacer (convection models)**

<b>Double Clear</b>	<b>Spacer Keff = 1.9 W/mK</b>						
<b>Section</b>	<b>T5/W5</b>	<b>2d</b>	<b>% diff</b>	<b>2D*</b>	<b>% diff</b>	<b>3d-overal</b>	<b>% diff</b>
	<b>W/m<sup>2</sup>K</b>	<b>W/m<sup>2</sup>K</b>	<b>2D vs. T5/W5</b>	<b>W/m<sup>2</sup>K</b>	<b>2D* vs. T5/W5</b>	<b>W/m<sup>2</sup>K</b>	<b>3D vs 2D</b>
Frame_sill	2.66	2.70	1%	2.73	3%	2.64	-2.3%
Frame_head	2.66	2.40	-10%	2.42	-9%	2.37	-0.9%
Frame_jamb	2.88	2.69	-6%	2.69	-6%	2.72	1.1%
Center of glass	2.80	2.70	-4%	2.70	-3%	2.70	0.2%
Edge_sill	3.15	3.65	16%	3.64	16%	3.66	0.1%
Edge_head	3.15	2.63	-16%	2.64	-16%	2.69	2.2%
Edge_jamb	3.14	2.99	-5%	2.99	-5%	3.05	2.1%
<b>TOTAL</b>	<b>2.89</b>	<b>2.77</b>	<b>-4%</b>	<b>2.78</b>	<b>-4%</b>	<b>2.79</b>	<b>0.5%</b>
<b>Double Low-e HC</b>	<b>Spacer Keff = 1.9 W/mK</b>						
<b>Section</b>	<b>T5/W5</b>	<b>2d</b>	<b>% diff</b>	<b>2D*</b>	<b>% diff</b>	<b>3d-overal</b>	<b>% diff</b>
	<b>W/m<sup>2</sup>K</b>	<b>W/m<sup>2</sup>K</b>	<b>2D vs. T5/W5</b>	<b>W/m<sup>2</sup>K</b>	<b>2D* vs. T5/W5</b>	<b>W/m<sup>2</sup>K</b>	<b>3D vs 2D</b>
Frame_sill	2.58	2.65	3%	2.69	4%	2.60	-1.9%
Frame_head	2.58	2.34	-9%	2.35	-9%	2.32	-0.9%
Frame_jamb	2.80	2.64	-6%	2.64	-6%	2.67	1.3%
Center of glass	1.73	1.55	-11%	1.56	-10%	1.57	1.4%
Edge_sill	2.36	3.02	28%	3.02	28%	3.05	1.1%
Edge_head	2.36	1.65	-30%	1.65	-30%	1.74	5.6%
Edge_jamb	2.36	2.13	-10%	2.13	-10%	2.23	4.5%
<b>TOTAL</b>	<b>2.20</b>	<b>2.04</b>	<b>-7%</b>	<b>2.05</b>	<b>-7%</b>	<b>2.08</b>	<b>1.6%</b>
<b>Double Low-e sC</b>	<b>Spacer Keff = 1.9 W/mK</b>						
<b>Section</b>	<b>T5/W5</b>	<b>2d</b>	<b>% diff</b>	<b>2D*</b>	<b>% diff</b>	<b>3d-overal</b>	<b>% diff</b>
	<b>W/m<sup>2</sup>K</b>	<b>W/m<sup>2</sup>K</b>	<b>2D vs. T5/W5</b>	<b>W/m<sup>2</sup>K</b>	<b>2D* vs. T5/W5</b>	<b>W/m<sup>2</sup>K</b>	<b>3D vs 2D</b>
Frame_sill	2.56	2.65	4%	2.69	5%	2.60	-2.0%
Frame_head	2.56	2.31	-10%	2.34	-9%	2.30	-0.6%
Frame_jamb	2.78	2.62	-6%	2.62	-6%	2.66	1.3%
Center of glass	1.47	1.25	-15%	1.26	-14%	1.27	1.8%
Edge_sill	2.18	2.90	34%	2.89	33%	2.93	0.9%
Edge_head	2.17	1.38	-37%	1.39	-36%	1.49	8.4%
Edge_jamb	2.17	1.92	-12%	1.92	-12%	2.02	5.3%
<b>TOTAL</b>	<b>2.03</b>	<b>1.86</b>	<b>-9%</b>	<b>1.86</b>	<b>-8%</b>	<b>1.89</b>	<b>1.9%</b>

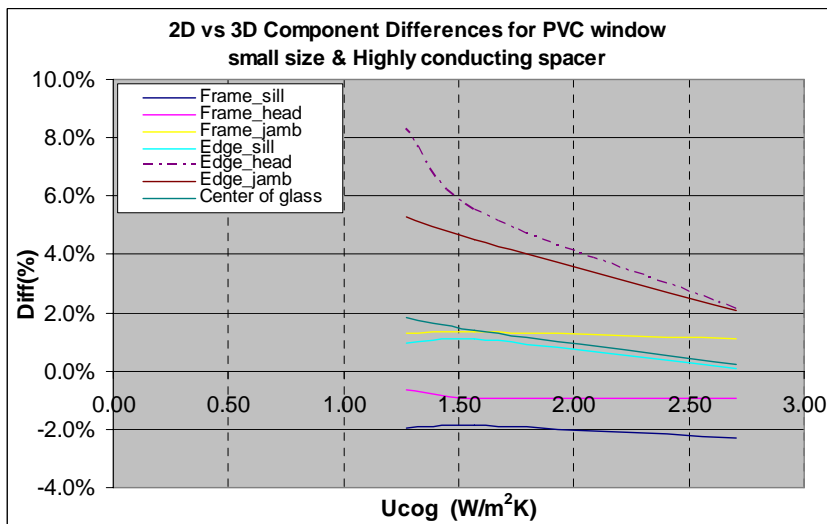
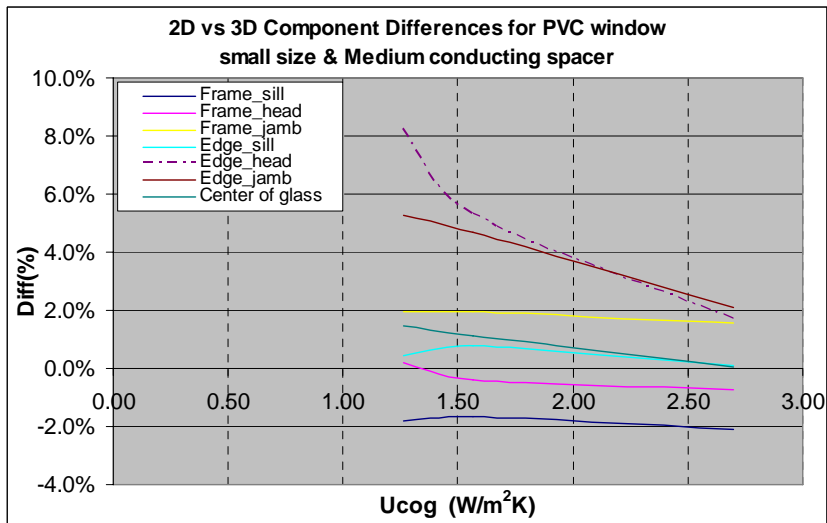
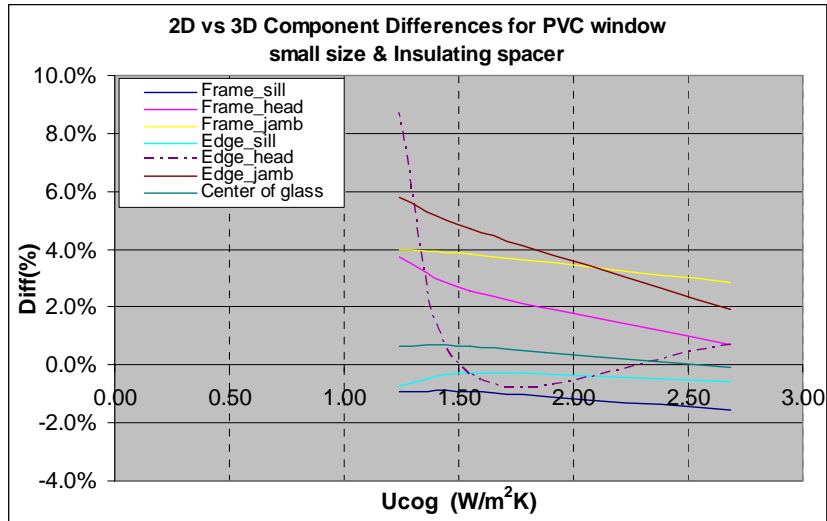

**Figure 6.5-6: Component Level Difference Graphs for small Size PVC Window (convection models)**

### 6.5.5 Component level results and comparisons for wood window (conduction models)

**Table 6.5-19: Wood Window - Large Size, Insulating Spacer (Conduction models)**

<b>Dbi Clear</b>		<b>Spacer keff = 0.050</b>		<b>W/mK</b>			
<b>Section</b>	<b>T5/W5</b>	<b>2-D</b>	<b>% diff</b>	<b>2-D*</b>	<b>% diff</b>	<b>3-D</b>	<b>% diff</b>
	<b>W/m<sup>2</sup>K</b>	<b>W/m<sup>2</sup>K</b>	<b>2D vs T5/W5</b>	<b>W/m<sup>2</sup>K</b>	<b>2D* vs T5/W5</b>	<b>W/m<sup>2</sup>K</b>	<b>3D vs 2-D</b>
Frame_sill	1.87	1.83	-2.36%	1.83	-2.31%	1.78	-2.41%
Frame_head	1.87	1.83	-2.36%	1.80	-3.91%	1.78	-2.31%
Frame_jamb	1.89	1.83	-3.51%	1.80	-5.20%	1.81	-0.93%
Center of glass	2.77	2.77	0.00%	2.77	0.00%	2.77	-0.01%
Edge_sill	2.76	2.75	-0.35%	2.75	-0.34%	2.75	0.11%
Edge_head	2.76	2.75	-0.35%	2.75	-0.34%	2.75	0.15%
Edge_jamb	2.77	2.75	-0.64%	2.75	-0.63%	2.75	0.03%
<b>TOTAL</b>	<b>2.60</b>	<b>2.58</b>	<b>-0.52%</b>	<b>2.58</b>	<b>-0.71%</b>	<b>2.58</b>	<b>-0.21%</b>
<b>Dbi Low-e HC</b>							
		<b>Spacer keff = 0.050</b>		<b>W/mK</b>			
<b>Section</b>	<b>T5/W5</b>	<b>2-D</b>	<b>% diff</b>	<b>2-D*</b>	<b>% diff</b>	<b>3-D</b>	<b>% diff</b>
	<b>W/m<sup>2</sup>K</b>	<b>W/m<sup>2</sup>K</b>	<b>2D vs T5/W5</b>	<b>W/m<sup>2</sup>K</b>	<b>2D* vs T5/W5</b>	<b>W/m<sup>2</sup>K</b>	<b>3D vs 2-D</b>
Frame_sill	1.68	1.64	-2.59%	1.64	-2.54%	1.61	-1.33%
Frame_head	1.68	1.64	-2.46%	1.61	-4.23%	1.62	-1.38%
Frame_jamb	1.72	1.64	-5.28%	1.61	-6.97%	1.63	-0.42%
Center of glass	1.72	1.74	0.79%	1.74	0.79%	1.74	0.16%
Edge_sill	1.88	1.88	-0.04%	1.88	-0.03%	1.91	1.26%
Edge_head	1.88	1.88	-0.03%	1.88	-0.04%	1.91	1.29%
Edge_jamb	1.89	1.88	-0.51%	1.88	-0.59%	1.89	0.33%
<b>TOTAL</b>	<b>1.76</b>	<b>1.75</b>	<b>-0.23%</b>	<b>1.75</b>	<b>-0.49%</b>	<b>1.76</b>	<b>0.07%</b>
<b>Dbi Low-e SC</b>							
		<b>Spacer keff = 0.050</b>		<b>W/mK</b>			
<b>Section</b>	<b>T5/W5</b>	<b>2-D</b>	<b>% diff</b>	<b>2-D*</b>	<b>% diff</b>	<b>3-D</b>	<b>% diff</b>
	<b>W/m<sup>2</sup>K</b>	<b>W/m<sup>2</sup>K</b>	<b>2D vs T5/W5</b>	<b>W/m<sup>2</sup>K</b>	<b>2D* vs T5/W5</b>	<b>W/m<sup>2</sup>K</b>	<b>3D vs 2-D</b>
Frame_sill	1.63	1.59	-2.95%	1.59	-2.90%	1.57	-0.99%
Frame_head	1.63	1.59	-2.76%	1.56	-4.56%	1.57	-1.06%
Frame_jamb	1.66	1.59	-4.34%	1.56	-6.01%	1.58	-0.28%
Center of glass	1.46	1.45	-0.61%	1.45	-0.60%	1.46	0.28%
Edge_sill	1.67	1.65	-1.23%	1.65	-1.23%	1.68	1.82%
Edge_head	1.67	1.65	-1.23%	1.65	-1.23%	1.68	1.85%
Edge_jamb	1.68	1.65	-1.78%	1.65	-1.90%	1.66	0.48%
<b>TOTAL</b>	<b>1.55</b>	<b>1.53</b>	<b>-1.42%</b>	<b>1.52</b>	<b>-1.73%</b>	<b>1.53</b>	<b>0.22%</b>
<b>Hypothetical R10</b>							
		<b>Spacer keff = 0.050</b>		<b>W/mK</b>			
<b>Section</b>	<b>T5/W5</b>	<b>2-D</b>	<b>% diff</b>	<b>2-D*</b>	<b>% diff</b>	<b>3-D</b>	<b>% diff</b>
	<b>W/m<sup>2</sup>K</b>	<b>W/m<sup>2</sup>K</b>	<b>2D vs T5/W5</b>	<b>W/m<sup>2</sup>K</b>	<b>2D* vs T5/W5</b>	<b>W/m<sup>2</sup>K</b>	<b>3D vs 2-D</b>
Frame_sill	1.48	1.45	-1.97%	1.45	-1.93%	1.45	0.11%
Frame_head	1.47	1.45	-1.77%	1.42	-3.65%	1.45	0.03%
Frame_jamb	1.50	1.45	-3.56%	1.42	-5.24%	1.45	0.19%
Center of glass	0.58	0.58	-0.07%	0.58	-0.05%	0.58	1.60%
Edge_sill	1.00	0.96	-4.39%	0.95	-4.41%	1.01	5.23%
Edge_head	1.00	0.96	-4.23%	0.95	-4.30%	1.01	5.20%
Edge_jamb	1.01	0.96	-5.65%	0.95	-6.10%	0.97	1.38%
<b>TOTAL</b>	<b>0.86</b>	<b>0.84</b>	<b>-2.45%</b>	<b>0.84</b>	<b>-3.01%</b>	<b>0.85</b>	<b>1.24%</b>

**Table 6.5-20: Wood Window – Large Size, Medium Conducting Spacer (Conduction models)**

<b>Dbf Clear</b>		<b>Spacer keff = 0.674</b>		<b>W/mK</b>			
<b>Section</b>	<b>T5/W5</b>	<b>2-D</b>	<b>% diff</b>	<b>2-D*</b>	<b>% diff</b>	<b>3-D</b>	<b>% diff</b>
	<b>W/m<sup>2</sup>K</b>	<b>W/m<sup>2</sup>K</b>	<b>2D vs T5/W5</b>	<b>W/m<sup>2</sup>K</b>	<b>2D* vs T5/W5</b>	<b>W/m<sup>2</sup>K</b>	<b>3D vs 2-D</b>
Frame_sill	2.33	2.31	-0.83%	2.31	-0.78%	2.24	-3.15%
Frame_head	2.33	2.32	-0.50%	2.28	-2.03%	2.24	-3.20%
Frame_jamb	2.33	2.31	-0.70%	2.28	-2.17%	2.29	-1.14%
Center of glass	2.77	2.77	0.05%	2.77	0.06%	2.77	0.15%
Edge_sill	3.05	3.05	0.29%	3.05	0.29%	3.09	1.10%
Edge_head	3.05	3.05	0.31%	3.05	0.30%	3.09	1.15%
Edge_jamb	3.05	3.05	0.23%	3.05	-0.03%	3.06	0.11%
<b>TOTAL</b>	<b>2.76</b>	<b>2.76</b>	<b>-0.06%</b>	<b>2.75</b>	<b>-0.31%</b>	<b>2.75</b>	<b>-0.13%</b>
<b>Dbf Low-e HC</b>		<b>Spacer keff = 0.674</b>		<b>W/mK</b>			
<b>Section</b>	<b>T5/W5</b>	<b>2-D</b>	<b>% diff</b>	<b>2-D*</b>	<b>% diff</b>	<b>3-D</b>	<b>% diff</b>
	<b>W/m<sup>2</sup>K</b>	<b>W/m<sup>2</sup>K</b>	<b>2D vs T5/W5</b>	<b>W/m<sup>2</sup>K</b>	<b>2D* vs T5/W5</b>	<b>W/m<sup>2</sup>K</b>	<b>3D vs 2-D</b>
Frame_sill	2.23	2.21	-0.68%	2.21	-0.63%	2.16	-2.67%
Frame_head	2.23	2.22	-0.38%	2.18	-1.94%	2.16	-2.71%
Frame_jamb	2.25	2.21	-1.54%	2.18	-3.04%	2.19	-0.96%
Center of glass	1.72	1.74	0.92%	1.74	0.93%	1.75	0.61%
Edge_sill	2.27	2.29	1.04%	2.29	1.03%	2.36	2.68%
Edge_head	2.27	2.29	1.06%	2.29	1.05%	2.36	2.67%
Edge_jamb	2.27	2.29	0.90%	2.28	0.40%	2.30	0.41%
<b>TOTAL</b>	<b>1.96</b>	<b>1.97</b>	<b>0.57%</b>	<b>1.96</b>	<b>0.19%</b>	<b>1.98</b>	<b>0.23%</b>
<b>Dbf Low-e SC</b>		<b>Spacer keff = 0.674</b>		<b>W/mK</b>			
<b>Section</b>	<b>T5/W5</b>	<b>2-D</b>	<b>% diff</b>	<b>2-D*</b>	<b>% diff</b>	<b>3-D</b>	<b>% diff</b>
	<b>W/m<sup>2</sup>K</b>	<b>W/m<sup>2</sup>K</b>	<b>2D vs T5/W5</b>	<b>W/m<sup>2</sup>K</b>	<b>2D* vs T5/W5</b>	<b>W/m<sup>2</sup>K</b>	<b>3D vs 2-D</b>
Frame_sill	2.20	2.19	-0.73%	2.19	-0.69%	2.13	-2.53%
Frame_head	2.20	2.19	-0.35%	2.16	-1.91%	2.13	-2.69%
Frame_jamb	2.22	2.19	-1.65%	2.16	-3.15%	2.17	-0.91%
Center of glass	1.46	1.45	-0.42%	1.45	-0.41%	1.47	0.89%
Edge_sill	2.08	2.09	0.43%	2.09	0.43%	2.16	3.32%
Edge_head	2.08	2.09	0.41%	2.09	0.40%	2.16	3.37%
Edge_jamb	2.09	2.09	0.29%	2.08	-0.32%	2.10	0.55%
<b>TOTAL</b>	<b>1.76</b>	<b>1.76</b>	<b>-0.31%</b>	<b>1.75</b>	<b>-0.75%</b>	<b>1.77</b>	<b>0.40%</b>
<b>Hypothetical R10</b>		<b>Spacer keff = 0.674</b>		<b>W/mK</b>			
<b>Section</b>	<b>T5/W5</b>	<b>2-D</b>	<b>% diff</b>	<b>2-D*</b>	<b>% diff</b>	<b>3-D</b>	<b>% diff</b>
	<b>W/m<sup>2</sup>K</b>	<b>W/m<sup>2</sup>K</b>	<b>2D vs T5/W5</b>	<b>W/m<sup>2</sup>K</b>	<b>2D* vs T5/W5</b>	<b>W/m<sup>2</sup>K</b>	<b>3D vs 2-D</b>
Frame_sill	2.10	2.12	0.82%	2.12	0.87%	2.07	-2.10%
Frame_head	2.10	2.12	0.99%	2.09	-0.57%	2.08	-2.16%
Frame_jamb	2.12	2.12	-0.08%	2.08	-1.57%	2.10	-0.74%
Center of glass	0.58	0.58	0.61%	0.58	0.66%	0.60	3.67%
Edge_sill	1.53	1.48	-3.37%	1.48	-3.35%	1.58	6.33%
Edge_head	1.54	1.48	-3.45%	1.48	-3.48%	1.58	6.36%
Edge_jamb	1.54	1.48	-3.64%	1.47	-4.70%	1.50	1.23%
<b>TOTAL</b>	<b>1.12</b>	<b>1.11</b>	<b>-0.81%</b>	<b>1.10</b>	<b>-1.53%</b>	<b>1.12</b>	<b>1.45%</b>



**Table 6.5-21: Wood Window – Large Size, Highly Conducting Spacer**

<b>Dbf Clear</b>	<b>Spacer keff = 1.900</b>			<b>W/mK</b>			
<b>Section</b>	<b>T5/W5</b>	<b>2-D</b>	<b>% diff</b>	<b>2-D*</b>	<b>% diff</b>	<b>3-D</b>	<b>% diff</b>
	<b>W/m<sup>2</sup>K</b>	<b>W/m<sup>2</sup>K</b>	<b>2D vs T5/W5</b>	<b>W/m<sup>2</sup>K</b>	<b>2D* vs T5/W5</b>	<b>W/m<sup>2</sup>K</b>	<b>3D vs 2-D</b>
Frame_sill	2.53	2.49	-1.73%	2.49	-1.68%	2.41	-3.47%
Frame_head	2.53	2.49	-1.37%	2.46	-2.88%	2.41	-3.64%
Frame_jamb	2.55	2.49	-2.45%	2.45	-4.01%	2.46	-1.34%
Center of glass	2.77	2.77	0.07%	2.77	0.08%	2.77	0.21%
Edge_sill	3.18	3.17	-0.20%	3.17	-0.20%	3.22	1.39%
Edge_head	3.18	3.17	-0.16%	3.17	-0.16%	3.22	1.40%
Edge_jamb	3.18	3.17	-0.23%	3.16	-0.65%	3.17	0.06%
<b>TOTAL</b>	<b>2.83</b>	<b>2.82</b>	<b>-0.33%</b>	<b>2.81</b>	<b>-0.63%</b>	<b>2.82</b>	<b>-0.14%</b>

<b>Dbf Low-e HC</b>	<b>Spacer keff = 1.900</b>			<b>W/mK</b>			
<b>Section</b>	<b>T5/W5</b>	<b>2-D</b>	<b>% diff</b>	<b>2-D*</b>	<b>% diff</b>	<b>3-D</b>	<b>% diff</b>
	<b>W/m<sup>2</sup>K</b>	<b>W/m<sup>2</sup>K</b>	<b>2D vs T5/W5</b>	<b>W/m<sup>2</sup>K</b>	<b>2D* vs T5/W5</b>	<b>W/m<sup>2</sup>K</b>	<b>3D vs 2-D</b>
Frame_sill	2.42	2.41	-0.38%	2.42	-0.35%	2.34	-3.14%
Frame_head	2.42	2.42	-0.23%	2.38	-1.70%	2.35	-3.13%
Frame_jamb	2.44	2.41	-1.16%	2.38	-2.75%	2.39	-1.25%
Center of glass	1.72	1.74	0.97%	1.74	0.98%	1.75	0.76%
Edge_sill	2.42	2.44	0.88%	2.44	0.86%	2.52	2.98%
Edge_head	2.42	2.44	0.86%	2.44	0.83%	2.52	3.04%
Edge_jamb	2.43	2.44	0.80%	2.43	0.07%	2.45	0.31%
<b>TOTAL</b>	<b>2.04</b>	<b>2.05</b>	<b>0.58%</b>	<b>2.04</b>	<b>0.12%</b>	<b>2.05</b>	<b>0.21%</b>

<b>Dbf Low-e SC</b>	<b>Spacer keff = 1.900</b>			<b>W/mK</b>			
<b>Section</b>	<b>T5/W5</b>	<b>2-D</b>	<b>% diff</b>	<b>2-D*</b>	<b>% diff</b>	<b>3-D</b>	<b>% diff</b>
	<b>W/m<sup>2</sup>K</b>	<b>W/m<sup>2</sup>K</b>	<b>2D vs T5/W5</b>	<b>W/m<sup>2</sup>K</b>	<b>2D* vs T5/W5</b>	<b>W/m<sup>2</sup>K</b>	<b>3D vs 2-D</b>
Frame_sill	2.41	2.40	-0.38%	2.40	-0.34%	2.33	-3.04%
Frame_head	2.41	2.40	-0.18%	2.36	-1.70%	2.33	-3.08%
Frame_jamb	2.43	2.40	-1.21%	2.36	-2.80%	2.37	-1.21%
Center of glass	1.46	1.45	-0.35%	1.46	-0.34%	1.47	1.10%
Edge_sill	2.25	2.25	0.22%	2.25	0.23%	2.34	3.65%
Edge_head	2.25	2.25	0.25%	2.25	0.19%	2.33	3.61%
Edge_jamb	2.25	2.25	0.18%	2.23	-0.64%	2.26	0.46%
<b>TOTAL</b>	<b>1.84</b>	<b>1.84</b>	<b>-0.24%</b>	<b>1.83</b>	<b>-0.76%</b>	<b>1.85</b>	<b>0.39%</b>

<b>Hypothetical R10</b>	<b>Spacer keff = 1.900</b>			<b>W/mK</b>			
<b>Section</b>	<b>T5/W5</b>	<b>2-D</b>	<b>% diff</b>	<b>2-D*</b>	<b>% diff</b>	<b>3-D</b>	<b>% diff</b>
	<b>W/m<sup>2</sup>K</b>	<b>W/m<sup>2</sup>K</b>	<b>2D vs T5/W5</b>	<b>W/m<sup>2</sup>K</b>	<b>2D* vs T5/W5</b>	<b>W/m<sup>2</sup>K</b>	<b>3D vs 2-D</b>
Frame_sill	2.33	2.34	0.61%	2.34	0.68%	2.28	-2.71%
Frame_head	2.33	2.34	0.81%	2.31	-0.67%	2.28	-2.75%
Frame_jamb	2.34	2.34	-0.16%	2.30	-1.70%	2.32	-1.07%
Center of glass	0.58	0.58	0.84%	0.58	0.91%	0.61	4.36%
Edge_sill	1.75	1.67	-4.71%	1.67	-4.66%	1.78	6.45%
Edge_head	1.75	1.67	-4.74%	1.67	-4.72%	1.79	6.52%
Edge_jamb	1.75	1.67	-4.77%	1.65	-6.07%	1.69	1.07%
<b>TOTAL</b>	<b>1.21</b>	<b>1.20</b>	<b>-1.31%</b>	<b>1.19</b>	<b>-2.12%</b>	<b>1.21</b>	<b>1.41%</b>

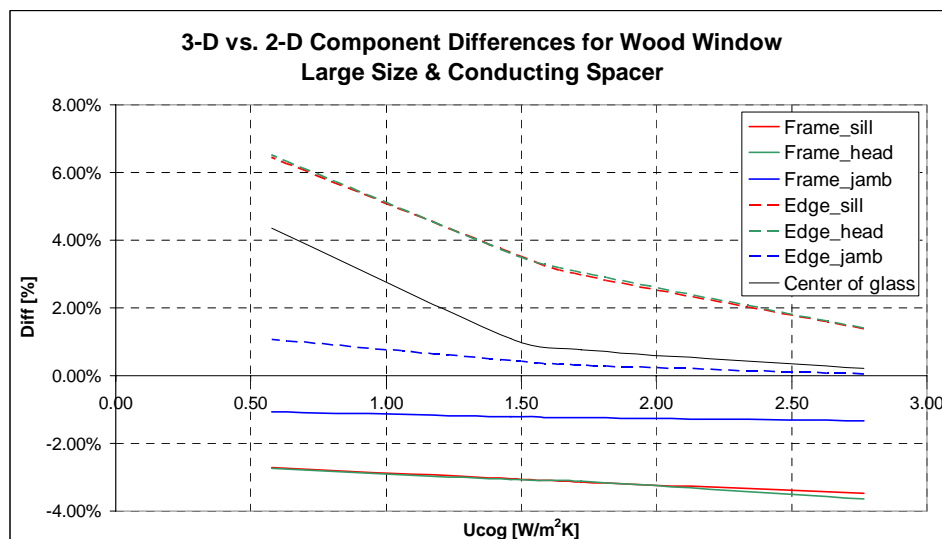
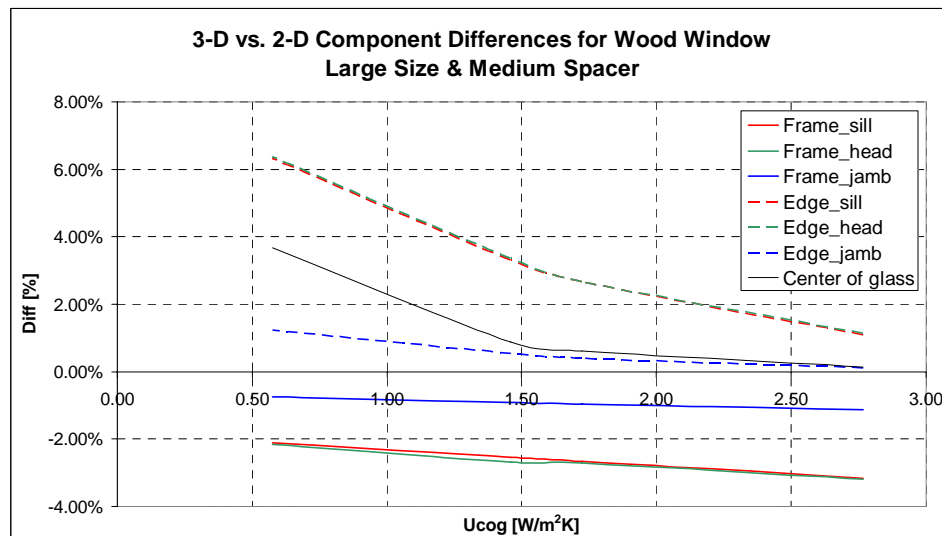
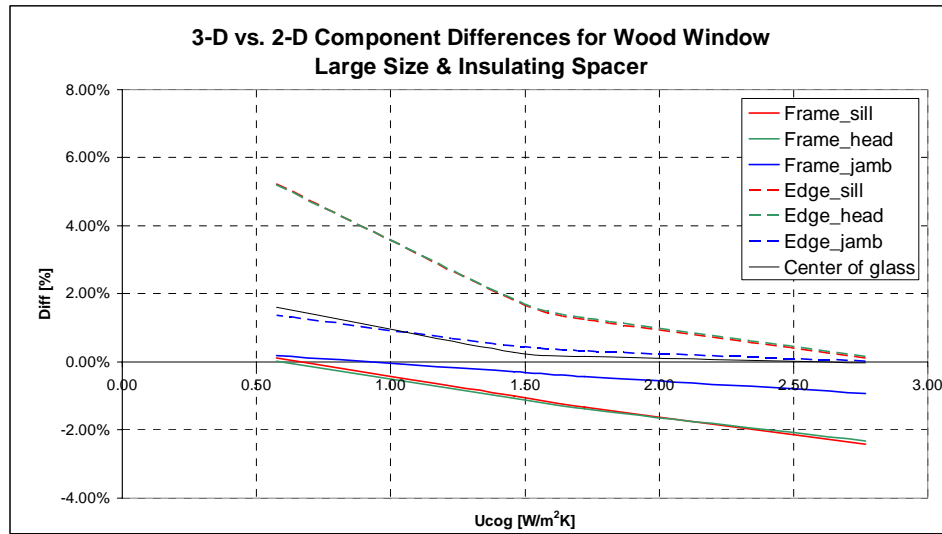

Figure 6.5-7: Component Level Difference Graphs for Large Size Wood Window

**Table 6.5-22: Wood Window – Medium Size, Insulating Spacer (conduction model)**

<b>Dbi Clear</b>		<b>Spacer keff = 0.050 W/mK</b>					
<b>Section</b>	<b>T5/W5</b>	<b>2-D</b>	<b>% diff</b>	<b>2-D*</b>	<b>% diff</b>	<b>3-D</b>	<b>% diff</b>
	<b>W/m<sup>2</sup>K</b>	<b>W/m<sup>2</sup>K</b>	<b>2D vs T5/W5</b>	<b>W/m<sup>2</sup>K</b>	<b>2D* vs T5/W5</b>	<b>W/m<sup>2</sup>K</b>	<b>3D vs 2-D</b>
Frame_sill	1.87	1.83	-2.37%	1.83	-2.30%	1.78	-2.43%
Frame_head	1.87	1.83	-2.22%	1.80	-3.90%	1.78	-2.46%
Frame_jamb	1.89	1.83	-3.52%	1.79	-5.41%	1.81	-1.13%
Center of glass	2.77	2.77	0.00%	2.77	0.00%	2.77	-0.01%
Edge_sill	2.76	2.75	-0.34%	2.75	-0.34%	2.75	0.09%
Edge_head	2.76	2.75	-0.35%	2.75	-0.33%	2.75	0.11%
Edge_jamb	2.77	2.75	-0.63%	2.75	-0.62%	2.75	0.04%
<b>TOTAL</b>	<b>2.59</b>	<b>2.57</b>	<b>-0.54%</b>	<b>2.57</b>	<b>-0.75%</b>	<b>2.57</b>	<b>-0.26%</b>
<b>Dbi Low-e HC</b>							
<b>Dbi Low-e HC</b>		<b>Spacer keff = 0.050 W/mK</b>					
<b>Section</b>	<b>T5/W5</b>	<b>2-D</b>	<b>% diff</b>	<b>2-D*</b>	<b>% diff</b>	<b>3-D</b>	<b>% diff</b>
	<b>W/m<sup>2</sup>K</b>	<b>W/m<sup>2</sup>K</b>	<b>2D vs T5/W5</b>	<b>W/m<sup>2</sup>K</b>	<b>2D* vs T5/W5</b>	<b>W/m<sup>2</sup>K</b>	<b>3D vs 2-D</b>
Frame_sill	1.68	1.64	-2.58%	1.64	-2.52%	1.61	-1.37%
Frame_head	1.68	1.64	-2.45%	1.61	-4.20%	1.62	-1.41%
Frame_jamb	1.70	1.64	-3.93%	1.61	-5.91%	1.63	-0.62%
Center of glass	1.72	1.74	0.80%	1.74	0.80%	1.74	0.15%
Edge_sill	1.88	1.88	-0.04%	1.88	0.02%	1.91	1.26%
Edge_head	1.88	1.88	-0.04%	1.88	0.02%	1.91	1.23%
Edge_jamb	1.89	1.88	-0.51%	1.88	-0.45%	1.89	0.58%
<b>TOTAL</b>	<b>1.76</b>	<b>1.76</b>	<b>-0.24%</b>	<b>1.75</b>	<b>-0.51%</b>	<b>1.76</b>	<b>0.08%</b>
<b>Dbi Low-e SC</b>							
<b>Dbi Low-e SC</b>		<b>Spacer keff = 0.050 W/mK</b>					
<b>Section</b>	<b>T5/W5</b>	<b>2-D</b>	<b>% diff</b>	<b>2-D*</b>	<b>% diff</b>	<b>3-D</b>	<b>% diff</b>
	<b>W/m<sup>2</sup>K</b>	<b>W/m<sup>2</sup>K</b>	<b>2D vs T5/W5</b>	<b>W/m<sup>2</sup>K</b>	<b>2D* vs T5/W5</b>	<b>W/m<sup>2</sup>K</b>	<b>3D vs 2-D</b>
Frame_sill	1.63	1.59	-2.95%	1.59	-2.90%	1.57	-1.04%
Frame_head	1.63	1.59	-2.76%	1.56	-4.55%	1.57	-1.05%
Frame_jamb	1.66	1.59	-4.34%	1.56	-6.34%	1.58	-0.45%
Center of glass	1.46	1.45	-0.58%	1.45	-0.58%	1.46	0.26%
Edge_sill	1.67	1.65	-1.25%	1.65	-1.23%	1.68	1.80%
Edge_head	1.67	1.65	-1.25%	1.65	-1.17%	1.68	1.82%
Edge_jamb	1.68	1.65	-1.80%	1.65	-1.70%	1.66	0.85%
<b>TOTAL</b>	<b>1.56</b>	<b>1.53</b>	<b>-1.47%</b>	<b>1.53</b>	<b>-1.78%</b>	<b>1.54</b>	<b>0.26%</b>
<b>Hypothetical R10</b>							
<b>Hypothetical R10</b>		<b>Spacer keff = 0.050 W/mK</b>					
<b>Section</b>	<b>T5/W5</b>	<b>2-D</b>	<b>% diff</b>	<b>2-D*</b>	<b>% diff</b>	<b>3-D</b>	<b>% diff</b>
	<b>W/m<sup>2</sup>K</b>	<b>W/m<sup>2</sup>K</b>	<b>2D vs T5/W5</b>	<b>W/m<sup>2</sup>K</b>	<b>2D* vs T5/W5</b>	<b>W/m<sup>2</sup>K</b>	<b>3D vs 2-D</b>
Frame_sill	1.48	1.45	-1.97%	1.45	-1.91%	1.45	0.04%
Frame_head	1.47	1.45	-1.78%	1.42	-3.63%	1.45	0.02%
Frame_jamb	1.50	1.45	-3.57%	1.42	-5.64%	1.45	0.07%
Center of glass	0.58	0.58	0.08%	0.58	0.07%	0.58	1.45%
Edge_sill	1.00	0.95	-4.44%	0.96	-4.24%	1.01	5.34%
Edge_head	1.00	0.95	-4.30%	0.96	-4.13%	1.01	5.33%
Edge_jamb	1.01	0.95	-5.74%	0.96	-5.46%	0.98	2.55%
<b>TOTAL</b>	<b>0.88</b>	<b>0.86</b>	<b>-2.37%</b>	<b>0.85</b>	<b>-2.87%</b>	<b>0.87</b>	<b>1.42%</b>

**Table 6.5-23: Wood Window – Medium Size, Medium Conducting Spacer  
(CONDUCTION MODEL)**

<b>Dbf Clear</b>		<b>Spacer keff = 0.674 W/mK</b>						
<b>Section</b>	<b>T5/W5</b>	<b>2-D</b>	<b>% diff</b>	<b>2-D*</b>	<b>% diff</b>	<b>3-D</b>	<b>% diff</b>	
	<b>W/m<sup>2</sup>K</b>	<b>W/m<sup>2</sup>K</b>	<b>2D vs T5/W5</b>	<b>W/m<sup>2</sup>K</b>	<b>2D* vs T5/W5</b>	<b>W/m<sup>2</sup>K</b>	<b>3D vs 2-D</b>	
Frame_sill	2.33	2.31	-0.84%	2.31	-0.79%	2.24	-3.16%	
Frame_head	2.33	2.31	-0.71%	2.28	-2.03%	2.24	-2.99%	
Frame_jamb	2.33	2.31	-0.71%	2.27	-2.38%	2.28	-1.46%	
Center of glass	2.77	2.77	0.06%	2.77	0.07%	2.77	0.13%	
Edge_sill	3.05	3.05	0.27%	3.06	0.30%	3.09	1.13%	
Edge_head	3.05	3.05	0.30%	3.05	0.32%	3.09	1.14%	
Edge_jamb	3.05	3.05	0.20%	3.06	0.24%	3.07	0.51%	
<b>TOTAL</b>	<b>2.76</b>	<b>2.75</b>	<b>-0.07%</b>	<b>2.75</b>	<b>-0.28%</b>	<b>2.75</b>	<b>-0.11%</b>	
<b>Dbf Low-e HC</b>								
		<b>Spacer keff = 0.674 W/mK</b>						
<b>Section</b>	<b>T5/W5</b>	<b>2-D</b>	<b>% diff</b>	<b>2-D*</b>	<b>% diff</b>	<b>3-D</b>	<b>% diff</b>	
	<b>W/m<sup>2</sup>K</b>	<b>W/m<sup>2</sup>K</b>	<b>2D vs T5/W5</b>	<b>W/m<sup>2</sup>K</b>	<b>2D* vs T5/W5</b>	<b>W/m<sup>2</sup>K</b>	<b>3D vs 2-D</b>	
Frame_sill	2.23	2.21	-0.70%	2.21	-0.64%	2.15	-2.68%	
Frame_head	2.23	2.22	-0.40%	2.18	-1.94%	2.16	-2.69%	
Frame_jamb	2.25	2.21	-1.55%	2.18	-3.25%	2.19	-1.22%	
Center of glass	1.72	1.74	0.97%	1.74	0.97%	1.75	0.55%	
Edge_sill	2.27	2.29	0.95%	2.29	1.09%	2.36	2.78%	
Edge_head	2.27	2.29	1.00%	2.29	1.11%	2.36	2.73%	
Edge_jamb	2.27	2.29	0.82%	2.30	0.97%	2.32	1.29%	
<b>TOTAL</b>	<b>1.97</b>	<b>1.98</b>	<b>0.57%</b>	<b>1.98</b>	<b>0.31%</b>	<b>1.99</b>	<b>0.35%</b>	
<b>Dbf Low-e SC</b>								
		<b>Spacer keff = 0.674 W/mK</b>						
<b>Section</b>	<b>T5/W5</b>	<b>2-D</b>	<b>% diff</b>	<b>2-D*</b>	<b>% diff</b>	<b>3-D</b>	<b>% diff</b>	
	<b>W/m<sup>2</sup>K</b>	<b>W/m<sup>2</sup>K</b>	<b>2D vs T5/W5</b>	<b>W/m<sup>2</sup>K</b>	<b>2D* vs T5/W5</b>	<b>W/m<sup>2</sup>K</b>	<b>3D vs 2-D</b>	
Frame_sill	2.20	2.19	-0.75%	2.19	-0.68%	2.13	-2.51%	
Frame_head	2.20	2.19	-0.37%	2.16	-1.89%	2.14	-2.67%	
Frame_jamb	2.22	2.19	-1.67%	2.15	-3.35%	2.16	-1.12%	
Center of glass	1.46	1.46	-0.34%	1.46	-0.34%	1.47	0.80%	
Edge_sill	2.08	2.09	0.36%	2.09	0.53%	2.19	4.42%	
Edge_head	2.08	2.09	0.34%	2.09	0.51%	2.19	4.42%	
Edge_jamb	2.09	2.09	0.22%	2.09	0.40%	2.12	1.66%	
<b>TOTAL</b>	<b>1.78</b>	<b>1.77</b>	<b>-0.28%</b>	<b>1.77</b>	<b>-0.57%</b>	<b>1.79</b>	<b>0.57%</b>	
<b>Hypothetical R10</b>								
		<b>Spacer keff = 0.674 W/mK</b>						
<b>Section</b>	<b>T5/W5</b>	<b>2-D</b>	<b>% diff</b>	<b>2-D*</b>	<b>% diff</b>	<b>3-D</b>	<b>% diff</b>	
	<b>W/m<sup>2</sup>K</b>	<b>W/m<sup>2</sup>K</b>	<b>2D vs T5/W5</b>	<b>W/m<sup>2</sup>K</b>	<b>2D* vs T5/W5</b>	<b>W/m<sup>2</sup>K</b>	<b>3D vs 2-D</b>	
Frame_sill	2.10	2.12	0.81%	2.12	0.89%	2.07	-2.12%	
Frame_head	2.10	2.12	0.97%	2.09	-0.56%	2.08	-2.14%	
Frame_jamb	2.12	2.12	-0.09%	2.07	-2.23%	2.10	-0.93%	
Center of glass	0.58	0.58	0.96%	0.58	0.95%	0.60	3.33%	
Edge_sill	1.53	1.48	-3.46%	1.49	-3.12%	1.59	6.63%	
Edge_head	1.54	1.48	-3.55%	1.49	-3.23%	1.59	6.62%	
Edge_jamb	1.54	1.48	-3.73%	1.40	-9.60%	1.53	3.15%	
<b>TOTAL</b>	<b>1.14</b>	<b>1.14</b>	<b>-0.73%</b>	<b>1.11</b>	<b>-2.68%</b>	<b>1.16</b>	<b>1.77%</b>	

**Table 6.5-24: Wood Window – Medium Size, Highly Conducting Spacer  
(CONDUCTION MODEL)**

<b>Dbl Clear</b>		<b>Spacer keff = 1.900</b>		<b>W/mK</b>			
<b>Section</b>	<b>T5/W5</b>	<b>2-D</b>	<b>% diff</b>	<b>2-D*</b>	<b>% diff</b>	<b>3-D</b>	<b>% diff</b>
	<b>W/m<sup>2</sup>K</b>	<b>W/m<sup>2</sup>K</b>	<b>2D vs T5/W5</b>	<b>W/m<sup>2</sup>K</b>	<b>2D* vs T5/W5</b>	<b>W/m<sup>2</sup>K</b>	<b>3D vs 2-D</b>
Frame_sill	2.53	2.49	-1.75%	2.49	-1.68%	2.41	-3.46%
Frame_head	2.53	2.49	-1.39%	2.46	-2.89%	2.41	-3.62%
Frame_jamb	2.55	2.49	-2.47%	2.45	-4.12%	2.45	-1.60%
Center of glass	2.77	2.77	0.09%	2.77	0.09%	2.77	0.19%
Edge_sill	3.18	3.17	-0.25%	3.17	-0.18%	3.22	1.43%
Edge_head	3.18	3.17	-0.21%	3.17	-0.14%	3.22	1.45%
Edge_jamb	3.18	3.17	-0.28%	3.17	-0.21%	3.19	0.66%
<b>TOTAL</b>	<b>2.83</b>	<b>2.82</b>	<b>-0.36%</b>	<b>2.81</b>	<b>-0.57%</b>	<b>2.82</b>	<b>-0.08%</b>
<b>Dbl Low-e HC</b>							
<b>Dbl Low-e HC</b>		<b>Spacer keff = 1.900</b>		<b>W/mK</b>			
<b>Section</b>	<b>T5/W5</b>	<b>2-D</b>	<b>% diff</b>	<b>2-D*</b>	<b>% diff</b>	<b>3-D</b>	<b>% diff</b>
	<b>W/m<sup>2</sup>K</b>	<b>W/m<sup>2</sup>K</b>	<b>2D vs T5/W5</b>	<b>W/m<sup>2</sup>K</b>	<b>2D* vs T5/W5</b>	<b>W/m<sup>2</sup>K</b>	<b>3D vs 2-D</b>
Frame_sill	2.42	2.41	-0.42%	2.42	-0.34%	2.34	-3.08%
Frame_head	2.42	2.42	-0.23%	2.38	-1.69%	2.35	-3.12%
Frame_jamb	2.44	2.41	-1.21%	2.38	-2.82%	2.38	-1.41%
Center of glass	1.72	1.74	1.05%	1.74	1.04%	1.75	0.69%
Edge_sill	2.42	2.44	0.78%	2.45	0.95%	2.52	3.22%
Edge_head	2.42	2.44	0.76%	2.45	0.92%	2.52	3.18%
Edge_jamb	2.43	2.44	0.70%	2.45	0.87%	2.48	1.50%
<b>TOTAL</b>	<b>2.05</b>	<b>2.07</b>	<b>0.59%</b>	<b>2.06</b>	<b>0.33%</b>	<b>2.07</b>	<b>0.41%</b>
<b>Dbl Low-e SC</b>							
<b>Dbl Low-e SC</b>		<b>Spacer keff = 1.900</b>		<b>W/mK</b>			
<b>Section</b>	<b>T5/W5</b>	<b>2-D</b>	<b>% diff</b>	<b>2-D*</b>	<b>% diff</b>	<b>3-D</b>	<b>% diff</b>
	<b>W/m<sup>2</sup>K</b>	<b>W/m<sup>2</sup>K</b>	<b>2D vs T5/W5</b>	<b>W/m<sup>2</sup>K</b>	<b>2D* vs T5/W5</b>	<b>W/m<sup>2</sup>K</b>	<b>3D vs 2-D</b>
Frame_sill	2.41	2.39	-0.43%	2.40	-0.33%	2.33	-2.98%
Frame_head	2.41	2.40	-0.23%	2.37	-1.69%	2.33	-3.02%
Frame_jamb	2.43	2.39	-1.26%	2.36	-2.87%	2.36	-1.33%
Center of glass	1.46	1.46	-0.24%	1.46	-0.25%	1.47	0.99%
Edge_sill	2.25	2.25	0.13%	2.25	0.34%	2.34	3.89%
Edge_head	2.25	2.25	0.10%	2.25	0.31%	2.34	3.89%
Edge_jamb	2.25	2.25	0.09%	2.25	0.30%	2.29	1.83%
<b>TOTAL</b>	<b>1.86</b>	<b>1.86</b>	<b>-0.15%</b>	<b>1.86</b>	<b>-0.43%</b>	<b>1.87</b>	<b>0.64%</b>
<b>Hypothetical R10</b>							
<b>Hypothetical R10</b>		<b>Spacer keff = 1.900</b>		<b>W/mK</b>			
<b>Section</b>	<b>T5/W5</b>	<b>2-D</b>	<b>% diff</b>	<b>2-D*</b>	<b>% diff</b>	<b>3-D</b>	<b>% diff</b>
	<b>W/m<sup>2</sup>K</b>	<b>W/m<sup>2</sup>K</b>	<b>2D vs T5/W5</b>	<b>W/m<sup>2</sup>K</b>	<b>2D* vs T5/W5</b>	<b>W/m<sup>2</sup>K</b>	<b>3D vs 2-D</b>
Frame_sill	2.33	2.34	0.58%	2.34	0.69%	2.28	-2.70%
Frame_head	2.33	2.34	0.79%	2.31	-0.66%	2.28	-2.73%
Frame_jamb	2.34	2.34	-0.19%	2.30	-1.78%	2.31	-1.19%
Center of glass	0.58	0.58	1.27%	0.58	1.25%	0.61	3.97%
Edge_sill	1.75	1.67	-4.84%	1.67	-4.43%	1.79	6.82%
Edge_head	1.75	1.67	-4.86%	1.67	-4.47%	1.79	6.81%
Edge_jamb	1.75	1.67	-4.90%	1.67	-4.49%	1.72	3.27%
<b>TOTAL</b>	<b>1.25</b>	<b>1.23</b>	<b>-1.17%</b>	<b>1.23</b>	<b>-1.54%</b>	<b>1.25</b>	<b>1.83%</b>

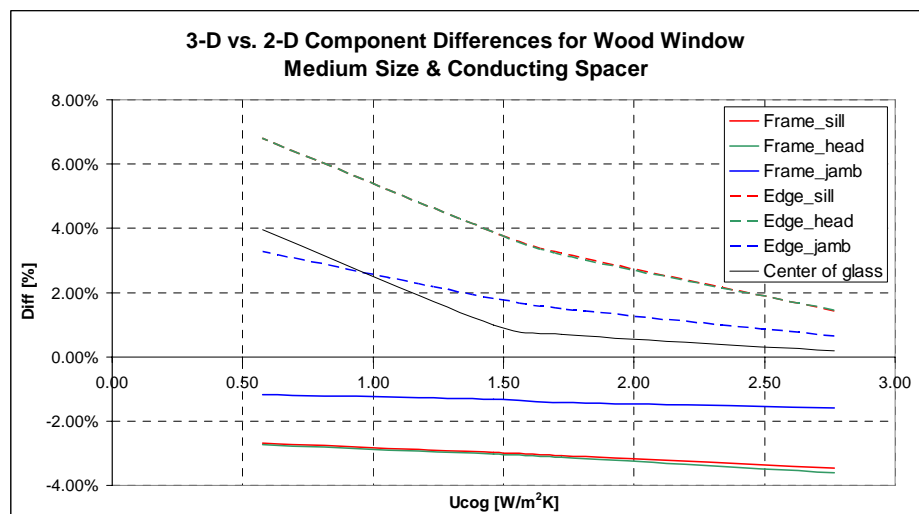
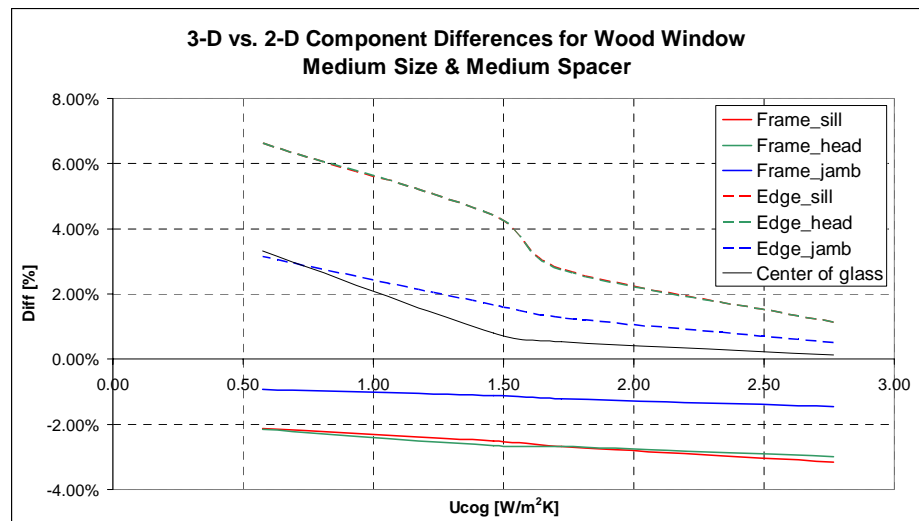
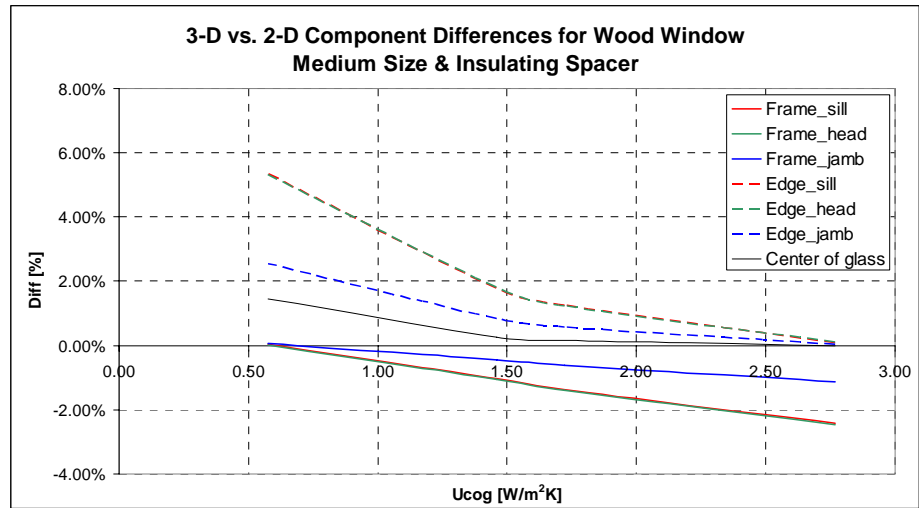

**Figure 6.5-8: Component Level Difference Graphs for Medium Size Wood Window**

**Table 6.5-25: Wood Window - Small Size, Insulating Spacer (CONDUCTION MODEL)**

<b>Dbl Clear</b>		<b>Spacer keff = 0.050 W/mK</b>					
<b>Section</b>	<b>T5/W5</b>	<b>2-D</b>	<b>% diff</b>	<b>2-D*</b>	<b>% diff</b>	<b>3-D</b>	<b>% diff</b>
	<b>W/m<sup>2</sup>K</b>	<b>W/m<sup>2</sup>K</b>	<b>2D vs T5/W5</b>	<b>W/m<sup>2</sup>K</b>	<b>2D* vs T5/W5</b>	<b>W/m<sup>2</sup>K</b>	<b>3D vs 2-D</b>
Frame_sill	1.87	1.83	-2.36%	1.83	-2.31%	1.78	-2.45%
Frame_head	1.87	1.83	-2.21%	1.80	-3.91%	1.78	-2.47%
Frame_jamb	1.89	1.82	-3.81%	1.80	-5.20%	1.80	-1.24%
Center of glass	2.77	2.77	0.00%	2.77	0.00%	2.77	-0.02%
Edge_sill	2.76	2.75	-0.34%	2.75	-0.34%	2.75	0.08%
Edge_head	2.76	2.75	-0.34%	2.75	-0.34%	2.75	0.09%
Edge_jamb	2.77	2.75	-0.61%	2.75	-0.63%	2.76	0.15%
<b>TOTAL</b>	<b>2.57</b>	<b>2.55</b>	<b>-0.64%</b>	<b>2.55</b>	<b>-0.82%</b>	<b>2.55</b>	<b>-0.28%</b>
<b>Dbl Low-e HC</b>		<b>Spacer keff = 0.050 W/mK</b>					
<b>Section</b>	<b>T5/W5</b>	<b>2-D</b>	<b>% diff</b>	<b>2-D*</b>	<b>% diff</b>	<b>3-D</b>	<b>% diff</b>
	<b>W/m<sup>2</sup>K</b>	<b>W/m<sup>2</sup>K</b>	<b>2D vs T5/W5</b>	<b>W/m<sup>2</sup>K</b>	<b>2D* vs T5/W5</b>	<b>W/m<sup>2</sup>K</b>	<b>3D vs 2-D</b>
Frame_sill	1.68	1.64	-2.58%	1.64	-2.55%	1.61	-1.38%
Frame_head	1.68	1.64	-2.45%	1.61	-4.24%	1.62	-1.41%
Frame_jamb	1.72	1.64	-5.27%	1.61	-7.00%	1.62	-0.79%
Center of glass	1.72	1.74	0.83%	1.74	0.83%	1.74	0.16%
Edge_sill	1.88	1.88	-0.04%	1.88	-0.05%	1.91	1.22%
Edge_head	1.88	1.88	-0.03%	1.88	-0.05%	1.91	1.23%
Edge_jamb	1.89	1.88	-0.51%	1.88	-0.58%	1.90	0.78%
<b>TOTAL</b>	<b>1.76</b>	<b>1.76</b>	<b>-0.35%</b>	<b>1.75</b>	<b>-0.64%</b>	<b>1.76</b>	<b>0.11%</b>
<b>Dbl Low-e SC</b>		<b>Spacer keff = 0.050 W/mK</b>					
<b>Section</b>	<b>T5/W5</b>	<b>2-D</b>	<b>% diff</b>	<b>2-D*</b>	<b>% diff</b>	<b>3-D</b>	<b>% diff</b>
	<b>W/m<sup>2</sup>K</b>	<b>W/m<sup>2</sup>K</b>	<b>2D vs T5/W5</b>	<b>W/m<sup>2</sup>K</b>	<b>2D* vs T5/W5</b>	<b>W/m<sup>2</sup>K</b>	<b>3D vs 2-D</b>
Frame_sill	1.63	1.59	-2.95%	1.59	-2.90%	1.57	-1.04%
Frame_head	1.63	1.59	-2.76%	1.56	-4.55%	1.57	-1.05%
Frame_jamb	1.66	1.59	-4.34%	1.57	-5.68%	1.58	-0.56%
Center of glass	1.46	1.45	-0.54%	1.45	-0.53%	1.46	0.29%
Edge_sill	1.67	1.65	-1.25%	1.65	-1.23%	1.68	1.80%
Edge_head	1.67	1.65	-1.25%	1.65	-1.22%	1.68	1.82%
Edge_jamb	1.68	1.65	-1.80%	1.64	-2.46%	1.67	1.10%
<b>TOTAL</b>	<b>1.56</b>	<b>1.54</b>	<b>-1.49%</b>	<b>1.53</b>	<b>-1.87%</b>	<b>1.54</b>	<b>0.34%</b>

**Table 6.5-26: Wood Window – Small Size, Medium Conducting Spacer  
(CONDUCTION MODEL)**

<b>DbI Clear</b>		<b>Spacer keff = 0.674 W/mK</b>					
<b>Section</b>	<b>T5/W5</b>	<b>2-D</b>	<b>% diff</b>	<b>2-D*</b>	<b>% diff</b>	<b>3-D</b>	<b>% diff</b>
	<b>W/m<sup>2</sup>K</b>	<b>W/m<sup>2</sup>K</b>	<b>2D vs T5/W5</b>	<b>W/m<sup>2</sup>K</b>	<b>2D* vs T5/W5</b>	<b>W/m<sup>2</sup>K</b>	<b>3D vs 2-D</b>
Frame_sill	2.33	2.31	-0.84%	2.31	-0.78%	2.24	-3.16%
Frame_head	2.33	2.31	-0.71%	2.28	-2.03%	2.24	-2.98%
Frame_jamb	2.33	2.31	-0.71%	2.28	-2.21%	2.27	-1.97%
Center of glass	2.77	2.77	0.09%	2.77	0.09%	2.77	0.15%
Edge_sill	3.05	3.05	0.27%	3.05	0.29%	3.09	1.12%
Edge_head	3.05	3.05	0.30%	3.05	0.31%	3.09	1.11%
Edge_jamb	3.05	3.05	0.20%	3.05	0.01%	3.07	0.59%
<b>TOTAL</b>	<b>2.75</b>	<b>2.75</b>	<b>-0.09%</b>	<b>2.74</b>	<b>-0.34%</b>	<b>2.74</b>	<b>-0.16%</b>
<b>DbI Low-e HC</b>		<b>Spacer keff = 0.674 W/mK</b>					
<b>Section</b>	<b>T5/W5</b>	<b>2-D</b>	<b>% diff</b>	<b>2-D*</b>	<b>% diff</b>	<b>3-D</b>	<b>% diff</b>
	<b>W/m<sup>2</sup>K</b>	<b>W/m<sup>2</sup>K</b>	<b>2D vs T5/W5</b>	<b>W/m<sup>2</sup>K</b>	<b>2D* vs T5/W5</b>	<b>W/m<sup>2</sup>K</b>	<b>3D vs 2-D</b>
Frame_sill	2.23	2.21	-0.70%	2.21	-0.64%	2.15	-2.68%
Frame_head	2.23	2.22	-0.40%	2.18	-1.94%	2.16	-2.71%
Frame_jamb	2.25	2.21	-1.55%	2.18	-3.10%	2.18	-1.68%
Center of glass	1.72	1.74	1.08%	1.74	1.09%	1.75	0.61%
Edge_sill	2.27	2.29	0.95%	2.29	1.03%	2.36	2.75%
Edge_head	2.27	2.29	1.00%	2.29	1.06%	2.36	2.73%
Edge_jamb	2.27	2.29	0.82%	2.28	0.46%	2.32	1.39%
<b>TOTAL</b>	<b>1.99</b>	<b>2.00</b>	<b>0.53%</b>	<b>2.00</b>	<b>0.17%</b>	<b>2.01</b>	<b>0.34%</b>
<b>DbI Low-e SC</b>		<b>Spacer keff = 0.674 W/mK</b>					
<b>Section</b>	<b>T5/W5</b>	<b>2-D</b>	<b>% diff</b>	<b>2-D*</b>	<b>% diff</b>	<b>3-D</b>	<b>% diff</b>
	<b>W/m<sup>2</sup>K</b>	<b>W/m<sup>2</sup>K</b>	<b>2D vs T5/W5</b>	<b>W/m<sup>2</sup>K</b>	<b>2D* vs T5/W5</b>	<b>W/m<sup>2</sup>K</b>	<b>3D vs 2-D</b>
Frame_sill	2.20	2.19	-0.75%	2.19	-0.69%	2.14	-2.43%
Frame_head	2.20	2.19	-0.36%	2.16	-1.91%	2.14	-2.53%
Frame_jamb	2.22	2.19	-1.66%	2.15	-3.22%	2.15	-1.57%
Center of glass	1.46	1.46	-0.19%	1.46	-0.18%	1.47	0.89%
Edge_sill	2.08	2.09	0.36%	2.09	0.43%	2.17	3.51%
Edge_head	2.08	2.09	0.34%	2.09	0.41%	2.17	3.51%
Edge_jamb	2.09	2.09	0.22%	2.08	-0.23%	2.13	1.78%
<b>TOTAL</b>	<b>1.80</b>	<b>1.80</b>	<b>-0.25%</b>	<b>1.79</b>	<b>-0.66%</b>	<b>1.81</b>	<b>0.58%</b>



**Table 6.5-27: Wood Window – Small Size, Highly Conducting Spacer  
(CONDUCTION MODEL)**

<b>DbI Clear</b>	<b>Spacer keff = 1.900 W/mK</b>						
<b>Section</b>	<b>T5/W5</b>	<b>2-D</b>	<b>% diff</b>	<b>2-D*</b>	<b>% diff</b>	<b>3-D</b>	<b>% diff</b>
	<b>W/m<sup>2</sup>K</b>	<b>W/m<sup>2</sup>K</b>	<b>2D vs T5/W5</b>	<b>W/m<sup>2</sup>K</b>	<b>2D* vs T5/W5</b>	<b>W/m<sup>2</sup>K</b>	<b>3D vs 2-D</b>
Frame_sill	2.53	2.49	-1.75%	2.49	-1.68%	2.41	-3.46%
Frame_head	2.53	2.49	-1.39%	2.46	-2.88%	2.41	-3.62%
Frame_jamb	2.55	2.49	-2.47%	2.45	-4.06%	2.43	-2.25%
Center of glass	2.77	2.77	0.13%	2.77	0.13%	2.78	0.21%
Edge_sill	3.18	3.17	-0.25%	3.17	-0.20%	3.22	1.43%
Edge_head	3.18	3.17	-0.21%	3.17	-0.16%	3.22	1.45%
Edge_jamb	3.18	3.17	-0.28%	3.16	-0.60%	3.19	0.65%
<b>TOTAL</b>	<b>2.83</b>	<b>2.82</b>	<b>-0.40%</b>	<b>2.81</b>	<b>-0.70%</b>	<b>2.82</b>	<b>-0.17%</b>
<b>DbI Low-e HC</b>	<b>Spacer keff = 1.900 W/mK</b>						
<b>Section</b>	<b>T5/W5</b>	<b>2-D</b>	<b>% diff</b>	<b>2-D*</b>	<b>% diff</b>	<b>3-D</b>	<b>% diff</b>
	<b>W/m<sup>2</sup>K</b>	<b>W/m<sup>2</sup>K</b>	<b>2D vs T5/W5</b>	<b>W/m<sup>2</sup>K</b>	<b>2D* vs T5/W5</b>	<b>W/m<sup>2</sup>K</b>	<b>3D vs 2-D</b>
Frame_sill	2.42	2.41	-0.42%	2.42	-0.35%	2.34	-3.10%
Frame_head	2.42	2.42	-0.23%	2.38	-1.70%	2.35	-3.13%
Frame_jamb	2.44	2.41	-1.21%	2.38	-2.81%	2.37	-2.05%
Center of glass	1.72	1.74	1.17%	1.74	1.09%	1.76	0.77%
Edge_sill	2.42	2.44	0.78%	2.44	0.84%	2.52	3.10%
Edge_head	2.42	2.44	0.76%	2.44	0.86%	2.52	3.10%
Edge_jamb	2.43	2.44	0.70%	2.43	0.17%	2.48	1.45%
<b>TOTAL</b>	<b>2.08</b>	<b>2.09</b>	<b>0.55%</b>	<b>2.08</b>	<b>0.10%</b>	<b>2.09</b>	<b>-0.02%</b>
<b>DbI Low-e SC</b>	<b>Spacer keff = 1.900 W/mK</b>						
<b>Section</b>	<b>T5/W5</b>	<b>2-D</b>	<b>% diff</b>	<b>2-D*</b>	<b>% diff</b>	<b>3-D</b>	<b>% diff</b>
	<b>W/m<sup>2</sup>K</b>	<b>W/m<sup>2</sup>K</b>	<b>2D vs T5/W5</b>	<b>W/m<sup>2</sup>K</b>	<b>2D* vs T5/W5</b>	<b>W/m<sup>2</sup>K</b>	<b>3D vs 2-D</b>
Frame_sill	2.41	2.39	-0.43%	2.40	-0.34%	2.33	-3.00%
Frame_head	2.41	2.40	-0.23%	2.36	-1.70%	2.33	-3.03%
Frame_jamb	2.43	2.39	-1.26%	2.36	-2.87%	2.35	-1.99%
Center of glass	1.46	1.46	-0.06%	1.46	-0.05%	1.48	1.10%
Edge_sill	2.25	2.25	0.13%	2.25	0.23%	2.34	3.75%
Edge_head	2.25	2.25	0.10%	2.25	0.21%	2.33	3.75%
Edge_jamb	2.25	2.25	0.09%	2.23	-0.52%	2.29	1.77%
<b>TOTAL</b>	<b>1.90</b>	<b>1.89</b>	<b>-0.19%</b>	<b>1.88</b>	<b>-0.65%</b>	<b>1.90</b>	<b>0.58%</b>

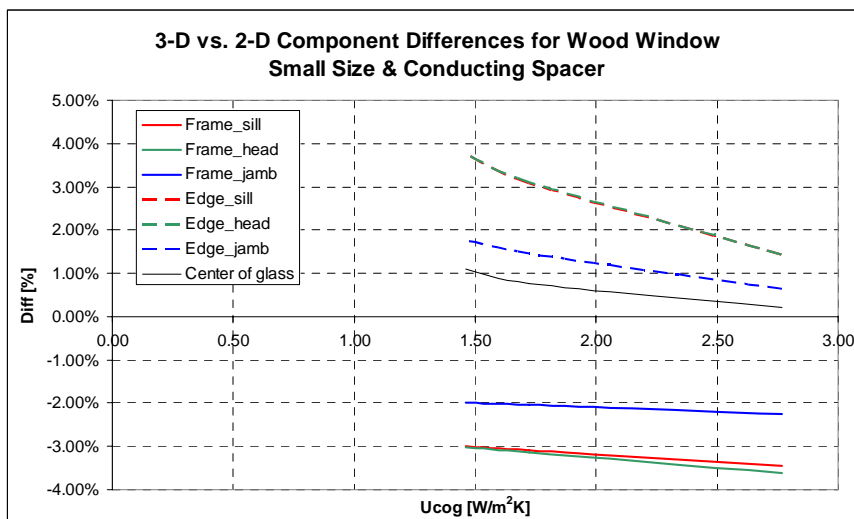
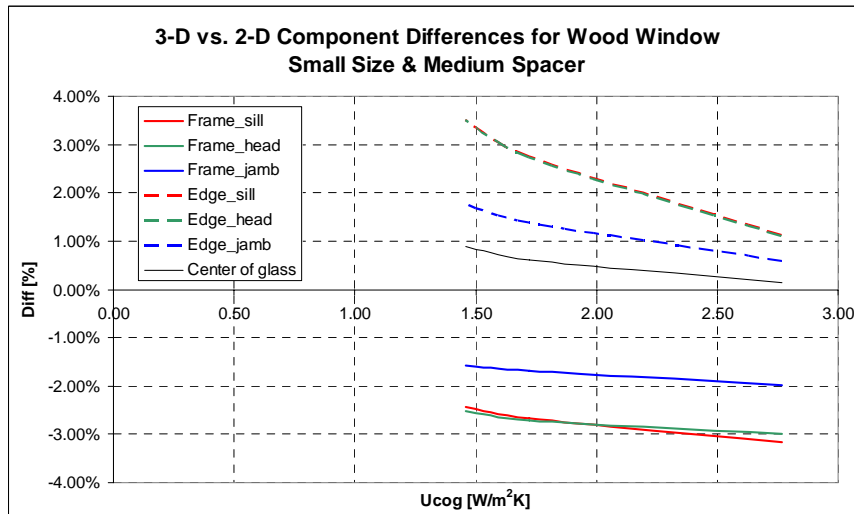
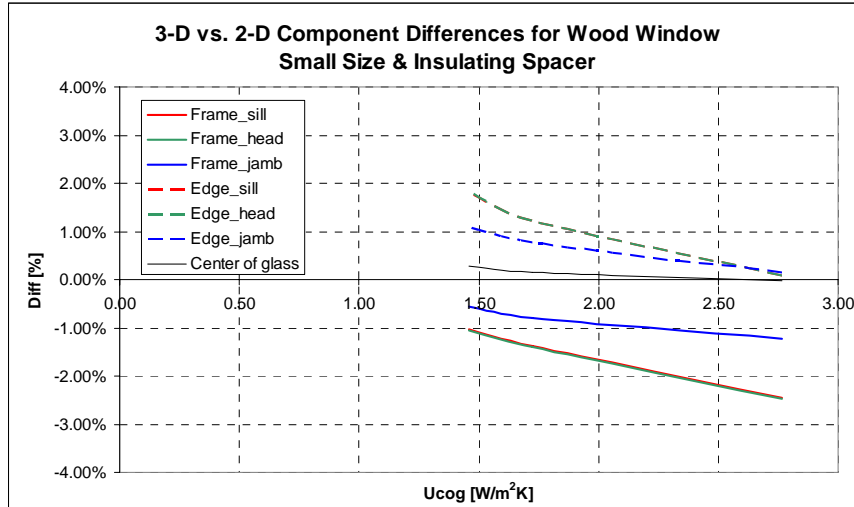

**Figure 6.5-9: Component Level Difference Graphs for Small Size Wood Window (conduction model)**

### 6.5.6 Component level results and comparisons for T/B AL window (conduction models)

**Table 6.5-28: T/B AL Window – Large Size, Insulating Spacer (Conduction models)**

<b>Dbf Clear</b>	<b>Spacer keff = 0.050 W/mK</b>						
<b>Section</b>	<b>T5/W5</b>	<b>2-D</b>	<b>% diff</b>	<b>2-D*</b>	<b>% diff</b>	<b>3-D</b>	<b>% diff</b>
	<b>W/m<sup>2</sup>K</b>	<b>W/m<sup>2</sup>K</b>	<b>2D vs T5/W5</b>	<b>W/m<sup>2</sup>K</b>	<b>2D* vs T5/W5</b>	<b>W/m<sup>2</sup>K</b>	<b>3D vs 2-D</b>
Frame_sill	5.02	4.84	-3.70%	5.08	1.21%	4.92	1.68%
Frame_head	4.99	4.84	-3.29%	5.08	1.68%	4.92	1.77%
Frame_jamb	5.38	5.10	-5.40%	5.10	-5.40%	5.15	0.95%
Center of glass	2.80	2.79	-0.07%	2.79	-0.11%	2.79	0.01%
Edge_sill	2.87	2.85	-0.63%	2.87	-0.04%	2.88	1.07%
Edge_head	2.87	2.85	-0.60%	2.87	0.02%	2.88	1.11%
Edge_jamb	2.90	2.88	-0.64%	2.88	-0.64%	2.83	-1.54%
<b>TOTAL</b>	<b>3.48</b>	<b>3.41</b>	<b>-2.07%</b>	<b>3.43</b>	<b>-1.53%</b>	<b>3.43</b>	<b>0.54%</b>
<b>Dbf Low-e HC</b>	<b>Spacer keff = 0.050 W/mK</b>						
<b>Section</b>	<b>T5/W5</b>	<b>2-D</b>	<b>% diff</b>	<b>2-D*</b>	<b>% diff</b>	<b>3-D</b>	<b>% diff</b>
	<b>W/m<sup>2</sup>K</b>	<b>W/m<sup>2</sup>K</b>	<b>2D vs T5/W5</b>	<b>W/m<sup>2</sup>K</b>	<b>2D* vs T5/W5</b>	<b>W/m<sup>2</sup>K</b>	<b>3D vs 2-D</b>
Frame_sill	4.83	4.66	-3.68%	4.92	1.74%	4.78	2.40%
Frame_head	4.83	4.65	-3.75%	4.92	1.79%	4.77	2.51%
Frame_jamb	5.19	4.94	-5.06%	4.94	-5.06%	4.99	1.10%
Center of glass	1.73	1.75	0.80%	1.75	0.77%	1.75	0.30%
Edge_sill	2.00	1.99	-0.42%	2.01	0.61%	2.05	2.92%
Edge_head	2.00	1.99	-0.50%	2.01	0.58%	2.05	2.98%
Edge_jamb	2.03	2.02	-0.38%	2.02	-0.38%	2.04	0.60%
<b>TOTAL</b>	<b>2.70</b>	<b>2.65</b>	<b>-2.11%</b>	<b>2.67</b>	<b>-1.34%</b>	<b>2.67</b>	<b>1.03%</b>
<b>Dbf Low-e SC</b>	<b>Spacer keff = 0.050 W/mK</b>						
<b>Section</b>	<b>T5/W5</b>	<b>2-D</b>	<b>% diff</b>	<b>2-D*</b>	<b>% diff</b>	<b>3-D</b>	<b>% diff</b>
	<b>W/m<sup>2</sup>K</b>	<b>W/m<sup>2</sup>K</b>	<b>2D vs T5/W5</b>	<b>W/m<sup>2</sup>K</b>	<b>2D* vs T5/W5</b>	<b>W/m<sup>2</sup>K</b>	<b>3D vs 2-D</b>
Frame_sill	4.79	4.62	-3.75%	4.88	1.91%	4.74	2.69%
Frame_head	4.79	4.61	-3.88%	4.88	1.85%	4.74	2.75%
Frame_jamb	5.16	4.90	-5.25%	4.90	-5.25%	4.96	1.15%
Center of glass	1.47	1.46	-0.59%	1.46	-0.61%	1.47	0.49%
Edge_sill	1.79	1.76	-1.52%	1.78	-0.26%	1.83	3.78%
Edge_head	1.79	1.76	-1.61%	1.78	-0.30%	1.83	3.84%
Edge_jamb	1.82	1.80	-1.46%	1.80	-1.46%	1.81	0.81%
<b>TOTAL</b>	<b>2.51</b>	<b>2.44</b>	<b>-2.99%</b>	<b>2.46</b>	<b>-2.13%</b>	<b>2.47</b>	<b>1.25%</b>
<b>Hypothetical R10</b>	<b>Spacer keff = 0.050 W/mK</b>						
<b>Section</b>	<b>T5/W5</b>	<b>2-D</b>	<b>% diff</b>	<b>2-D*</b>	<b>% diff</b>	<b>3-D</b>	<b>% diff</b>
	<b>W/m<sup>2</sup>K</b>	<b>W/m<sup>2</sup>K</b>	<b>2D vs T5/W5</b>	<b>W/m<sup>2</sup>K</b>	<b>2D* vs T5/W5</b>	<b>W/m<sup>2</sup>K</b>	<b>3D vs 2-D</b>
Frame_sill	4.65	4.49	-3.56%	4.77	2.43%	4.64	3.20%
Frame_head	4.65	4.48	-3.75%	4.76	2.38%	4.64	3.32%
Frame_jamb	5.02	4.88	-2.81%	4.78	-4.99%	4.84	-0.82%
Center of glass	0.58	0.58	0.30%	0.58	0.34%	0.59	2.43%
Edge_sill	1.11	1.07	-3.16%	1.10	-0.80%	1.17	8.34%
Edge_head	1.11	1.07	-3.40%	1.10	-0.89%	1.17	8.49%
Edge_jamb	1.15	1.12	-3.02%	1.12	-3.14%	1.14	1.88%
<b>TOTAL</b>	<b>1.87</b>	<b>1.83</b>	<b>-2.44%</b>	<b>1.83</b>	<b>-2.33%</b>	<b>1.85</b>	<b>1.07%</b>

**Table 6.5-29: T/B AL Window – Large Size, Medium Conducting Spacer  
(Conduction models)**

<b>Dbf Clear</b>	<b>Spacer keff = 0.674 W/mK</b>							
<b>Section</b>	<b>T5/W5</b>	<b>2-D</b>	<b>% diff</b>	<b>2-D*</b>	<b>% diff</b>	<b>3-D</b>	<b>% diff</b>	
	<b>W/m<sup>2</sup>K</b>	<b>W/m<sup>2</sup>K</b>	<b>2D vs T5/W5</b>	<b>W/m<sup>2</sup>K</b>	<b>2D* vs T5/W5</b>	<b>W/m<sup>2</sup>K</b>	<b>3D vs 2-D</b>	
Frame_sill	5.35	5.22	-2.41%	5.45	1.90%	5.27	0.90%	
Frame_head	5.35	5.22	-2.50%	5.45	1.82%	5.27	0.88%	
Frame_jamb	5.69	5.45	-4.26%	5.45	-4.26%	5.50	0.87%	
Center of glass	2.80	2.79	-0.04%	2.79	-0.07%	2.80	0.11%	
Edge_sill	3.05	3.04	-0.51%	3.05	-0.08%	3.09	1.52%	
Edge_head	3.05	3.04	-0.50%	3.05	-0.07%	3.09	1.52%	
Edge_jamb	3.07	3.05	-0.54%	3.05	-0.54%	3.06	0.37%	
<b>TOTAL</b>	<b>3.61</b>	<b>3.55</b>	<b>-1.62%</b>	<b>3.57</b>	<b>-1.13%</b>	<b>3.57</b>	<b>0.53%</b>	
<b>Dbf Low-e HC</b>	<b>Spacer keff = 0.674 W/mK</b>							
<b>Section</b>	<b>T5/W5</b>	<b>2-D</b>	<b>% diff</b>	<b>2-D*</b>	<b>% diff</b>	<b>3-D</b>	<b>% diff</b>	
	<b>W/m<sup>2</sup>K</b>	<b>W/m<sup>2</sup>K</b>	<b>2D vs T5/W5</b>	<b>W/m<sup>2</sup>K</b>	<b>2D* vs T5/W5</b>	<b>W/m<sup>2</sup>K</b>	<b>3D vs 2-D</b>	
Frame_sill	5.22	5.10	-2.30%	5.36	2.50%	5.18	1.49%	
Frame_head	5.23	5.11	-2.29%	5.36	2.40%	5.18	1.38%	
Frame_jamb	5.57	5.35	-4.01%	5.35	-4.01%	5.40	0.96%	
Center of glass	1.73	1.75	0.88%	1.75	0.85%	1.76	0.56%	
Edge_sill	2.25	2.24	-0.40%	2.25	0.34%	2.32	3.47%	
Edge_head	2.25	2.24	-0.38%	2.25	0.34%	2.32	3.46%	
Edge_jamb	2.26	2.25	-0.36%	2.25	-0.36%	2.28	0.89%	
<b>TOTAL</b>	<b>2.86</b>	<b>2.82</b>	<b>-1.55%</b>	<b>2.84</b>	<b>-0.88%</b>	<b>2.85</b>	<b>1.01%</b>	
<b>Dbf Low-e SC</b>	<b>Spacer keff = 0.674 W/mK</b>							
<b>Section</b>	<b>T5/W5</b>	<b>2-D</b>	<b>% diff</b>	<b>2-D*</b>	<b>% diff</b>	<b>3-D</b>	<b>% diff</b>	
	<b>W/m<sup>2</sup>K</b>	<b>W/m<sup>2</sup>K</b>	<b>2D vs T5/W5</b>	<b>W/m<sup>2</sup>K</b>	<b>2D* vs T5/W5</b>	<b>W/m<sup>2</sup>K</b>	<b>3D vs 2-D</b>	
Frame_sill	5.20	5.07	-2.47%	5.33	2.47%	5.16	1.65%	
Frame_head	5.20	5.08	-2.31%	5.33	2.44%	5.16	1.46%	
Frame_jamb	5.54	5.33	-4.09%	5.33	-4.09%	5.38	0.98%	
Center of glass	1.47	1.46	-0.47%	1.46	-0.42%	1.47	0.93%	
Edge_sill	2.05	2.03	-1.31%	2.05	-0.33%	2.12	4.38%	
Edge_head	2.05	2.03	-1.28%	2.04	-0.35%	2.12	4.33%	
Edge_jamb	2.07	2.05	-1.14%	2.05	-1.14%	2.07	1.15%	
<b>TOTAL</b>	<b>2.68</b>	<b>2.62</b>	<b>-2.29%</b>	<b>2.64</b>	<b>-1.52%</b>	<b>2.65</b>	<b>1.23%</b>	
<b>Hypothetical R10</b>	<b>Spacer keff = 0.674 W/mK</b>							
<b>Section</b>	<b>T5/W5</b>	<b>2-D</b>	<b>% diff</b>	<b>2-D*</b>	<b>% diff</b>	<b>3-D</b>	<b>% diff</b>	
	<b>W/m<sup>2</sup>K</b>	<b>W/m<sup>2</sup>K</b>	<b>2D vs T5/W5</b>	<b>W/m<sup>2</sup>K</b>	<b>2D* vs T5/W5</b>	<b>W/m<sup>2</sup>K</b>	<b>3D vs 2-D</b>	
Frame_sill	5.11	5.01	-1.90%	5.25	2.80%	5.09	1.53%	
Frame_head	5.11	5.00	-2.14%	5.25	2.79%	5.09	1.76%	
Frame_jamb	5.45	5.36	-1.72%	5.25	-3.84%	5.30	-1.00%	
Center of glass	0.58	0.58	0.72%	0.58	0.77%	0.60	3.65%	
Edge_sill	1.43	1.39	-2.87%	1.41	-1.61%	1.51	7.89%	
Edge_head	1.43	1.39	-2.97%	1.41	-1.61%	1.51	7.97%	
Edge_jamb	1.45	1.41	-2.92%	1.41	-2.97%	1.45	2.24%	
<b>TOTAL</b>	<b>2.07</b>	<b>2.03</b>	<b>-1.57%</b>	<b>2.03</b>	<b>-1.67%</b>	<b>2.05</b>	<b>0.93%</b>	

**Table 6.5-30: T/B AL Window – Large Size, Highly Conducting Spacer (Conduction models)**

<b>Dbf Clear</b>	<b>Spacer keff = 1.900 W/mK</b>						
<b>Section</b>	<b>T5/W5</b>	<b>2-D</b>	<b>% diff</b>	<b>2-D*</b>	<b>% diff</b>	<b>3-D</b>	<b>% diff</b>
	<b>W/m<sup>2</sup>K</b>	<b>W/m<sup>2</sup>K</b>	<b>2D vs T5/W5</b>	<b>W/m<sup>2</sup>K</b>	<b>2D* vs T5/W5</b>	<b>W/m<sup>2</sup>K</b>	<b>3D vs 2-D</b>
Frame_sill	5.52	5.39	-2.49%	5.62	1.73%	5.42	0.64%
Frame_head	5.51	5.40	-2.12%	5.62	1.90%	5.42	0.46%
Frame_jamb	5.85	5.62	-4.07%	5.62	-4.07%	5.67	0.77%
Center of glass	2.80	2.80	-0.02%	2.79	-0.06%	2.80	0.16%
Edge_sill	3.15	3.12	-0.72%	3.13	-0.33%	3.18	1.71%
Edge_head	3.14	3.12	-0.67%	3.03	-3.89%	3.18	1.70%
Edge_jamb	3.15	3.13	-0.69%	3.13	-0.69%	3.15	0.45%
<b>TOTAL</b>	<b>3.68</b>	<b>3.62</b>	<b>-1.61%</b>	<b>3.62</b>	<b>-1.47%</b>	<b>3.64</b>	<b>0.51%</b>
<b>Dbf Low-e HC</b>	<b>Spacer keff = 1.900 W/mK</b>						
<b>Section</b>	<b>T5/W5</b>	<b>2-D</b>	<b>% diff</b>	<b>2-D*</b>	<b>% diff</b>	<b>3-D</b>	<b>% diff</b>
	<b>W/m<sup>2</sup>K</b>	<b>W/m<sup>2</sup>K</b>	<b>2D vs T5/W5</b>	<b>W/m<sup>2</sup>K</b>	<b>2D* vs T5/W5</b>	<b>W/m<sup>2</sup>K</b>	<b>3D vs 2-D</b>
Frame_sill	5.42	5.31	-2.02%	5.54	2.21%	5.35	0.78%
Frame_head	5.41	5.31	-1.91%	5.54	2.38%	5.35	0.84%
Frame_jamb	5.76	5.54	-3.91%	5.54	-3.91%	5.59	0.86%
Center of glass	1.73	1.75	0.92%	1.75	0.89%	1.76	0.69%
Edge_sill	2.37	2.35	-0.73%	2.36	-0.14%	2.44	3.62%
Edge_head	2.36	2.35	-0.71%	2.36	-0.09%	2.44	3.64%
Edge_jamb	2.38	2.36	-0.72%	2.36	-0.72%	2.38	1.02%
<b>TOTAL</b>	<b>2.94</b>	<b>2.89</b>	<b>-1.54%</b>	<b>2.91</b>	<b>-0.93%</b>	<b>2.92</b>	<b>0.96%</b>
<b>Dbf Low-e SC</b>	<b>Spacer keff = 1.900 W/mK</b>						
<b>Section</b>	<b>T5/W5</b>	<b>2-D</b>	<b>% diff</b>	<b>2-D*</b>	<b>% diff</b>	<b>3-D</b>	<b>% diff</b>
	<b>W/m<sup>2</sup>K</b>	<b>W/m<sup>2</sup>K</b>	<b>2D vs T5/W5</b>	<b>W/m<sup>2</sup>K</b>	<b>2D* vs T5/W5</b>	<b>W/m<sup>2</sup>K</b>	<b>3D vs 2-D</b>
Frame_sill	5.40	5.29	-2.04%	5.52	2.20%	5.34	0.81%
Frame_head	5.39	5.29	-1.92%	5.52	2.42%	5.33	0.93%
Frame_jamb	5.74	5.52	-3.98%	5.52	-3.98%	5.57	0.88%
Center of glass	1.47	1.46	-0.42%	1.46	-0.44%	1.48	1.01%
Edge_sill	2.18	2.14	-1.61%	2.16	-0.95%	2.24	4.37%
Edge_head	2.18	2.14	-1.65%	2.16	-0.94%	2.24	4.40%
Edge_jamb	2.19	2.15	-1.62%	2.15	-1.62%	2.18	1.25%
<b>TOTAL</b>	<b>2.76</b>	<b>2.70</b>	<b>-2.26%</b>	<b>2.72</b>	<b>-1.59%</b>	<b>2.73</b>	<b>1.14%</b>
<b>Hypothetical R10</b>	<b>Spacer keff = 1.900 W/mK</b>						
<b>Section</b>	<b>T5/W5</b>	<b>2-D</b>	<b>% diff</b>	<b>2-D*</b>	<b>% diff</b>	<b>3-D</b>	<b>% diff</b>
	<b>W/m<sup>2</sup>K</b>	<b>W/m<sup>2</sup>K</b>	<b>2D vs T5/W5</b>	<b>W/m<sup>2</sup>K</b>	<b>2D* vs T5/W5</b>	<b>W/m<sup>2</sup>K</b>	<b>3D vs 2-D</b>
Frame_sill	5.33	5.23	-1.87%	5.46	2.48%	5.28	1.01%
Frame_head	5.31	5.22	-1.83%	5.46	2.75%	5.28	1.25%
Frame_jamb	5.65	5.57	-1.59%	5.45	-3.66%	5.51	-1.07%
Center of glass	0.58	0.58	0.89%	0.58	0.95%	0.61	4.18%
Edge_sill	1.58	1.53	-3.71%	1.54	-2.62%	1.66	7.87%
Edge_head	1.58	1.53	-3.81%	1.54	-2.62%	1.66	7.95%
Edge_jamb	1.60	1.54	-3.71%	1.54	-3.66%	1.58	2.40%
<b>TOTAL</b>	<b>2.16</b>	<b>2.12</b>	<b>-1.62%</b>	<b>2.12</b>	<b>-1.75%</b>	<b>2.14</b>	<b>0.91%</b>

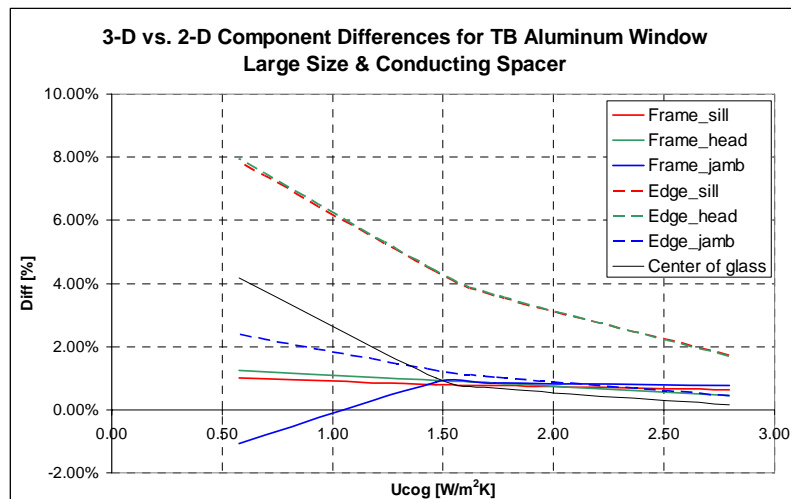
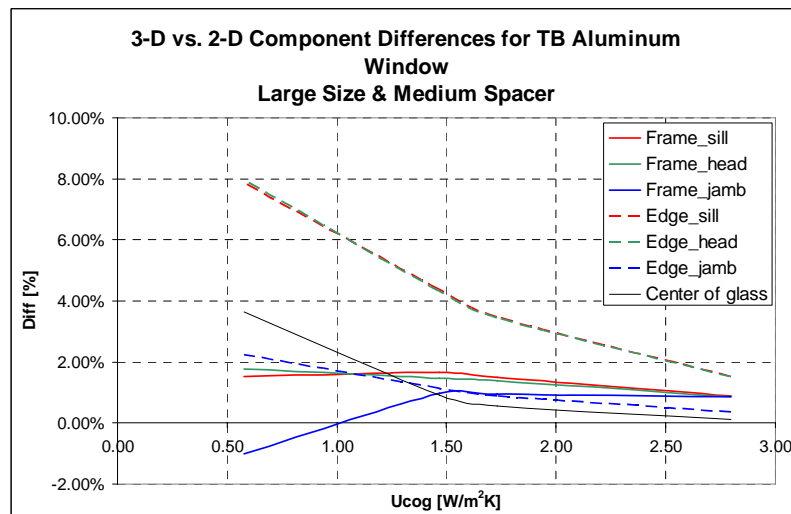
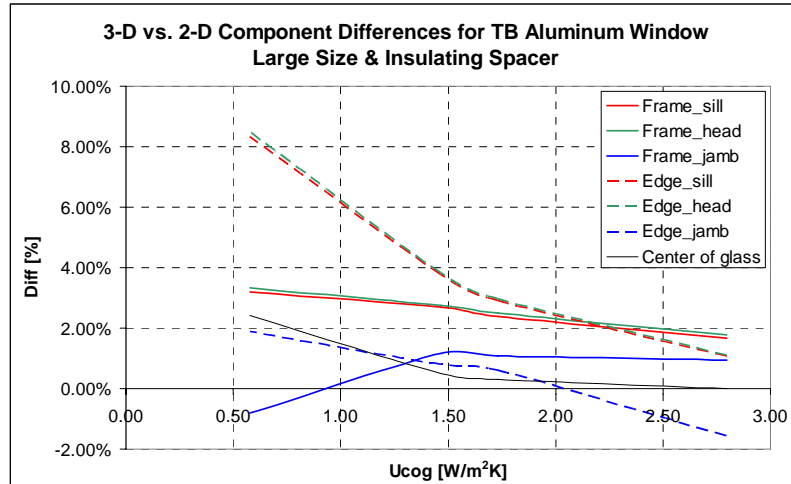

**Figure 6.5-10: Component Level Difference Graphs for Large Size T/B AL Window (Conduction Model)**

**Table 6.5-31: T/B AL Window – Medium Size, Insulating Spacer (Conduction models)**

<b>DbI Clear</b>		<b>Spacer keff = 0.050 W/mK</b>					
<b>Section</b>	<b>T5/W5</b>	<b>2-D</b>	<b>% diff</b>	<b>2-D*</b>	<b>% diff</b>	<b>3-D</b>	<b>% diff</b>
	<b>W/m<sup>2</sup>K</b>	<b>W/m<sup>2</sup>K</b>	<b>2D vs T5/W5</b>	<b>W/m<sup>2</sup>K</b>	<b>2D* vs T5/W5</b>	<b>W/m<sup>2</sup>K</b>	<b>3D vs 2-D</b>
Frame_sill	5.02	4.84	-3.68%	5.11	1.84%	4.96	2.30%
Frame_head	4.99	4.83	-3.34%	5.11	2.35%	4.96	2.48%
Frame_jamb	5.38	5.21	-3.22%	5.14	-4.59%	5.04	-3.37%
Center of glass	2.80	2.79	-0.11%	2.79	-0.10%	2.79	0.06%
Edge_sill	2.87	2.85	-0.62%	2.88	0.32%	2.89	1.50%
Edge_head	2.87	2.85	-0.60%	2.88	0.38%	2.89	1.55%
Edge_jamb	2.90	2.88	-0.59%	2.89	-0.20%	2.90	0.57%
<b>TOTAL</b>	<b>3.52</b>	<b>3.46</b>	<b>-1.51%</b>	<b>3.48</b>	<b>-1.03%</b>	<b>3.45</b>	<b>-0.43%</b>
<b>DbI Low-e HC</b>		<b>Spacer keff = 0.050 W/mK</b>					
<b>Section</b>	<b>T5/W5</b>	<b>2-D</b>	<b>% diff</b>	<b>2-D*</b>	<b>% diff</b>	<b>3-D</b>	<b>% diff</b>
	<b>W/m<sup>2</sup>K</b>	<b>W/m<sup>2</sup>K</b>	<b>2D vs T5/W5</b>	<b>W/m<sup>2</sup>K</b>	<b>2D* vs T5/W5</b>	<b>W/m<sup>2</sup>K</b>	<b>3D vs 2-D</b>
Frame_sill	4.83	4.66	-3.68%	4.95	2.46%	4.81	3.08%
Frame_head	4.83	4.66	-3.67%	4.95	2.54%	4.81	3.14%
Frame_jamb	5.19	5.04	-2.83%	4.98	-4.08%	4.89	-3.16%
Center of glass	1.73	1.75	0.78%	1.75	0.80%	1.75	0.35%
Edge_sill	2.00	1.99	-0.42%	2.02	1.06%	2.06	3.45%
Edge_head	2.00	1.99	-0.49%	2.02	1.05%	2.06	3.53%
Edge_jamb	2.03	2.03	-0.29%	2.04	0.23%	2.05	1.25%
<b>TOTAL</b>	<b>2.75</b>	<b>2.71</b>	<b>-1.38%</b>	<b>2.73</b>	<b>-0.65%</b>	<b>2.71</b>	<b>-0.15%</b>
<b>DbI Low-e SC</b>		<b>Spacer keff = 0.050 W/mK</b>					
<b>Section</b>	<b>T5/W5</b>	<b>2-D</b>	<b>% diff</b>	<b>2-D*</b>	<b>% diff</b>	<b>3-D</b>	<b>% diff</b>
	<b>W/m<sup>2</sup>K</b>	<b>W/m<sup>2</sup>K</b>	<b>2D vs T5/W5</b>	<b>W/m<sup>2</sup>K</b>	<b>2D* vs T5/W5</b>	<b>W/m<sup>2</sup>K</b>	<b>3D vs 2-D</b>
Frame_sill	4.79	4.62	-3.76%	4.91	2.51%	4.77	3.26%
Frame_head	4.79	4.61	-3.86%	4.91	2.49%	4.77	3.32%
Frame_jamb	5.16	5.00	-3.10%	4.94	-4.32%	4.85	-3.10%
Center of glass	1.47	1.46	-0.59%	1.46	-0.56%	1.47	0.54%
Edge_sill	1.79	1.76	-1.53%	1.79	0.19%	1.84	4.31%
Edge_head	1.79	1.76	-1.62%	1.79	0.18%	1.84	4.41%
Edge_jamb	1.82	1.80	-1.40%	1.81	-0.80%	1.83	1.56%
<b>TOTAL</b>	<b>2.57</b>	<b>2.51</b>	<b>-2.21%</b>	<b>2.53</b>	<b>-1.39%</b>	<b>2.51</b>	<b>-0.02%</b>
<b>Hypothetical R10</b>		<b>Spacer keff = 0.050 W/mK</b>					
<b>Section</b>	<b>T5/W5</b>	<b>2-D</b>	<b>% diff</b>	<b>2-D*</b>	<b>% diff</b>	<b>3-D</b>	<b>% diff</b>
	<b>W/m<sup>2</sup>K</b>	<b>W/m<sup>2</sup>K</b>	<b>2D vs T5/W5</b>	<b>W/m<sup>2</sup>K</b>	<b>2D* vs T5/W5</b>	<b>W/m<sup>2</sup>K</b>	<b>3D vs 2-D</b>
Frame_sill	4.65	4.49	-3.63%	4.80	3.07%	4.67	3.85%
Frame_head	4.65	4.48	-3.71%	4.80	3.07%	4.67	3.91%
Frame_jamb	5.02	4.88	-2.84%	4.83	-3.96%	4.74	-2.90%
Center of glass	0.58	0.58	0.47%	0.58	0.57%	0.59	2.46%
Edge_sill	1.11	1.07	-3.19%	1.10	-0.22%	1.18	9.02%
Edge_head	1.11	1.07	-3.39%	1.10	-0.23%	1.18	9.24%
Edge_jamb	1.15	1.12	-3.04%	1.13	-2.13%	1.16	3.26%
<b>TOTAL</b>	<b>1.94</b>	<b>1.90</b>	<b>-2.50%</b>	<b>1.92</b>	<b>-1.28%</b>	<b>1.91</b>	<b>0.60%</b>

**Table 6.5-32: T/B AL Window – Medium Size, medium conducting Spacer  
(Conduction models)**

<b>Dbi Clear</b>	<b>Spacer keff = 0.674 W/mK</b>						
<b>Section</b>	<b>T5/W5</b>	<b>2-D</b>	<b>% diff</b>	<b>2-D*</b>	<b>% diff</b>	<b>3-D</b>	<b>% diff</b>
	<b>W/m<sup>2</sup>K</b>	<b>W/m<sup>2</sup>K</b>	<b>2D vs T5/W5</b>	<b>W/m<sup>2</sup>K</b>	<b>2D* vs T5/W5</b>	<b>W/m<sup>2</sup>K</b>	<b>3D vs 2-D</b>
Frame_sill	5.35	5.23	-2.19%	5.49	2.54%	5.31	1.37%
Frame_head	5.35	5.22	-2.46%	5.49	2.48%	5.31	1.56%
Frame_jamb	5.69	5.57	-2.05%	5.50	-3.48%	5.39	-3.48%
Center of glass	2.80	2.79	-0.07%	2.79	-0.06%	2.80	0.16%
Edge_sill	3.05	3.04	-0.48%	3.07	0.45%	3.10	2.10%
Edge_head	3.05	3.04	-0.50%	3.07	0.44%	3.10	2.12%
Edge_jamb	3.07	3.05	-0.47%	3.07	0.06%	3.08	1.01%
<b>TOTAL</b>	<b>3.65</b>	<b>3.62</b>	<b>-1.00%</b>	<b>3.63</b>	<b>-0.61%</b>	<b>3.60</b>	<b>-0.48%</b>
<b>Dbi Low-e HC</b>	<b>Spacer keff = 0.674 W/mK</b>						
<b>Section</b>	<b>T5/W5</b>	<b>2-D</b>	<b>% diff</b>	<b>2-D*</b>	<b>% diff</b>	<b>3-D</b>	<b>% diff</b>
	<b>W/m<sup>2</sup>K</b>	<b>W/m<sup>2</sup>K</b>	<b>2D vs T5/W5</b>	<b>W/m<sup>2</sup>K</b>	<b>2D* vs T5/W5</b>	<b>W/m<sup>2</sup>K</b>	<b>3D vs 2-D</b>
Frame_sill	5.22	5.12	-1.94%	5.39	3.09%	5.21	1.79%
Frame_head	5.23	5.11	-2.27%	5.39	2.99%	5.21	1.99%
Frame_jamb	5.57	5.46	-1.90%	5.39	-3.21%	5.29	-3.30%
Center of glass	1.73	1.75	0.89%	1.75	0.92%	1.76	0.63%
Edge_sill	2.25	2.24	-0.32%	2.27	1.13%	2.34	4.29%
Edge_head	2.25	2.24	-0.37%	2.27	1.12%	2.34	4.34%
Edge_jamb	2.26	2.26	-0.31%	2.28	0.61%	2.30	2.05%
<b>TOTAL</b>	<b>2.92</b>	<b>2.90</b>	<b>-0.80%</b>	<b>2.92</b>	<b>-0.19%</b>	<b>2.89</b>	<b>-0.15%</b>
<b>Dbi Low-e SC</b>	<b>Spacer keff = 0.674 W/mK</b>						
<b>Section</b>	<b>T5/W5</b>	<b>2-D</b>	<b>% diff</b>	<b>2-D*</b>	<b>% diff</b>	<b>3-D</b>	<b>% diff</b>
	<b>W/m<sup>2</sup>K</b>	<b>W/m<sup>2</sup>K</b>	<b>2D vs T5/W5</b>	<b>W/m<sup>2</sup>K</b>	<b>2D* vs T5/W5</b>	<b>W/m<sup>2</sup>K</b>	<b>3D vs 2-D</b>
Frame_sill	5.20	5.09	-2.04%	5.36	3.09%	5.19	1.91%
Frame_head	5.20	5.08	-2.27%	5.36	3.08%	5.19	2.11%
Frame_jamb	5.54	5.44	-1.98%	5.37	-3.26%	5.26	-3.24%
Center of glass	1.47	1.46	-0.44%	1.46	-0.40%	1.48	0.91%
Edge_sill	2.05	2.03	-1.22%	2.06	0.46%	2.14	5.17%
Edge_head	2.05	2.03	-1.27%	2.06	0.45%	2.14	5.24%
Edge_jamb	2.07	2.04	-1.20%	2.07	-0.13%	2.10	2.48%
<b>TOTAL</b>	<b>2.74</b>	<b>2.70</b>	<b>-1.44%</b>	<b>2.72</b>	<b>-0.74%</b>	<b>2.70</b>	<b>-0.01%</b>
<b>Hypothetical R10</b>	<b>Spacer keff = 0.674 W/mK</b>						
<b>Section</b>	<b>T5/W5</b>	<b>2-D</b>	<b>% diff</b>	<b>2-D*</b>	<b>% diff</b>	<b>3-D</b>	<b>% diff</b>
	<b>W/m<sup>2</sup>K</b>	<b>W/m<sup>2</sup>K</b>	<b>2D vs T5/W5</b>	<b>W/m<sup>2</sup>K</b>	<b>2D* vs T5/W5</b>	<b>W/m<sup>2</sup>K</b>	<b>3D vs 2-D</b>
Frame_sill	5.11	5.01	-1.93%	5.29	3.45%	5.13	2.25%
Frame_head	5.11	5.00	-2.14%	5.29	3.46%	5.13	2.45%
Frame_jamb	5.45	5.36	-1.75%	5.29	-2.91%	5.20	-3.07%
Center of glass	0.58	0.58	1.01%	0.58	1.15%	0.60	3.73%
Edge_sill	1.43	1.39	-2.89%	1.43	-0.16%	1.54	9.35%
Edge_head	1.43	1.39	-2.98%	1.43	-0.17%	1.54	9.47%
Edge_jamb	1.45	1.41	-2.94%	1.44	-1.12%	1.48	4.52%
<b>TOTAL</b>	<b>2.15</b>	<b>2.11</b>	<b>-1.61%</b>	<b>2.13</b>	<b>-0.56%</b>	<b>2.13</b>	<b>0.62%</b>



**Table 6.5-33: T/B AL Window – Medium Size, Highly Conducting Spacer  
(Conduction Model)**

<b>Dbf Clear</b>		<b>Spacer keff =</b>		<b>1.900 W/mK</b>			
<b>Section</b>	<b>T5/W5</b>	<b>2-D</b>	<b>% diff</b>	<b>2-D*</b>	<b>% diff</b>	<b>3-D</b>	<b>% diff</b>
	<b>W/m<sup>2</sup>K</b>	<b>W/m<sup>2</sup>K</b>	<b>2D vs T5/W5</b>	<b>W/m<sup>2</sup>K</b>	<b>2D* vs T5/W5</b>	<b>W/m<sup>2</sup>K</b>	<b>3D vs 2-D</b>
Frame_sill	5.52	5.41	-2.13%	5.66	2.45%	5.47	1.12%
Frame_head	5.51	5.40	-2.09%	5.66	2.69%	5.47	1.32%
Frame_jamb	5.85	5.74	-1.91%	5.67	-3.24%	5.55	-3.42%
Center of glass	2.80	2.79	-0.05%	2.79	-0.04%	2.80	0.21%
Edge_sill	3.15	3.12	-0.67%	3.15	0.24%	3.20	2.35%
Edge_head	3.14	3.12	-0.66%	3.15	0.27%	3.20	2.36%
Edge_jamb	3.15	3.13	-0.64%	3.15	-0.01%	3.17	1.21%
<b>TOTAL</b>	<b>3.72</b>	<b>3.68</b>	<b>-0.98%</b>	<b>3.70</b>	<b>-0.56%</b>	<b>3.67</b>	<b>-0.44%</b>
<b>Dbf Low-e HC</b>		<b>Spacer keff =</b>		<b>1.900 W/mK</b>			
<b>Section</b>	<b>T5/W5</b>	<b>2-D</b>	<b>% diff</b>	<b>2-D*</b>	<b>% diff</b>	<b>3-D</b>	<b>% diff</b>
	<b>W/m<sup>2</sup>K</b>	<b>W/m<sup>2</sup>K</b>	<b>2D vs T5/W5</b>	<b>W/m<sup>2</sup>K</b>	<b>2D* vs T5/W5</b>	<b>W/m<sup>2</sup>K</b>	<b>3D vs 2-D</b>
Frame_sill	5.42	5.32	-1.90%	5.58	2.94%	5.40	1.47%
Frame_head	5.41	5.31	-1.92%	5.58	3.14%	5.40	1.68%
Frame_jamb	5.76	5.65	-1.81%	5.59	-3.02%	5.47	-3.24%
Center of glass	1.73	1.75	0.94%	1.75	0.97%	1.76	0.75%
Edge_sill	2.37	2.35	-0.71%	2.38	0.75%	2.46	4.60%
Edge_head	2.36	2.35	-0.72%	2.38	0.79%	2.46	4.65%
Edge_jamb	2.38	2.36	-0.70%	2.38	0.34%	2.42	2.31%
<b>TOTAL</b>	<b>3.00</b>	<b>2.98</b>	<b>-0.81%</b>	<b>3.00</b>	<b>-0.16%</b>	<b>2.98</b>	<b>-0.09%</b>
<b>Dbf Low-e SC</b>		<b>Spacer keff =</b>		<b>1.900 W/mK</b>			
<b>Section</b>	<b>T5/W5</b>	<b>2-D</b>	<b>% diff</b>	<b>2-D*</b>	<b>% diff</b>	<b>3-D</b>	<b>% diff</b>
	<b>W/m<sup>2</sup>K</b>	<b>W/m<sup>2</sup>K</b>	<b>2D vs T5/W5</b>	<b>W/m<sup>2</sup>K</b>	<b>2D* vs T5/W5</b>	<b>W/m<sup>2</sup>K</b>	<b>3D vs 2-D</b>
Frame_sill	5.40	5.30	-1.98%	5.56	2.94%	5.38	1.57%
Frame_head	5.39	5.28	-1.94%	5.56	3.19%	5.38	1.79%
Frame_jamb	5.74	5.63	-1.89%	5.57	-3.05%	5.46	-3.18%
Center of glass	1.47	1.46	-0.32%	1.46	-0.33%	1.48	1.02%
Edge_sill	2.18	2.14	-1.62%	2.18	0.07%	2.27	5.49%
Edge_head	2.18	2.14	-1.68%	2.18	0.07%	2.27	5.55%
Edge_jamb	2.19	2.15	-1.63%	2.18	-0.40%	2.22	2.77%
<b>TOTAL</b>	<b>2.83</b>	<b>2.79</b>	<b>-1.41%</b>	<b>2.81</b>	<b>-0.68%</b>	<b>2.79</b>	<b>0.05%</b>
<b>Hypothetical R10</b>		<b>Spacer keff =</b>		<b>1.900 W/mK</b>			
<b>Section</b>	<b>T5/W5</b>	<b>2-D</b>	<b>% diff</b>	<b>2-D*</b>	<b>% diff</b>	<b>3-D</b>	<b>% diff</b>
	<b>W/m<sup>2</sup>K</b>	<b>W/m<sup>2</sup>K</b>	<b>2D vs T5/W5</b>	<b>W/m<sup>2</sup>K</b>	<b>2D* vs T5/W5</b>	<b>W/m<sup>2</sup>K</b>	<b>3D vs 2-D</b>
Frame_sill	5.33	5.23	-1.90%	5.51	3.25%	5.33	1.87%
Frame_head	5.31	5.22	-1.82%	5.51	3.55%	5.33	2.09%
Frame_jamb	5.65	5.56	-1.61%	5.51	-2.64%	5.40	-3.01%
Center of glass	0.58	0.58	1.24%	0.58	1.40%	0.61	4.27%
Edge_sill	1.58	1.53	-3.72%	1.57	-0.95%	1.69	9.51%
Edge_head	1.58	1.53	-3.81%	1.57	-0.96%	1.69	9.63%
Edge_jamb	1.60	1.54	-3.72%	1.57	-1.63%	1.62	4.86%
<b>TOTAL</b>	<b>2.24</b>	<b>2.21</b>	<b>-1.61%</b>	<b>2.23</b>	<b>-0.50%</b>	<b>2.22</b>	<b>0.74%</b>

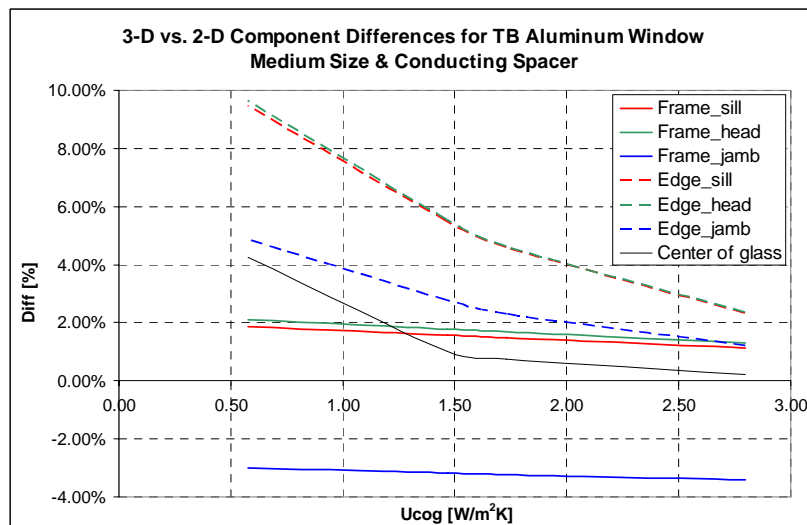
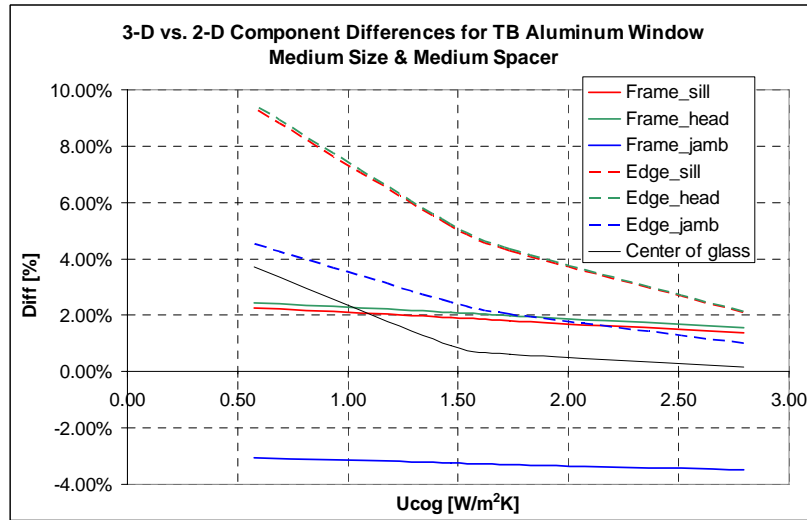
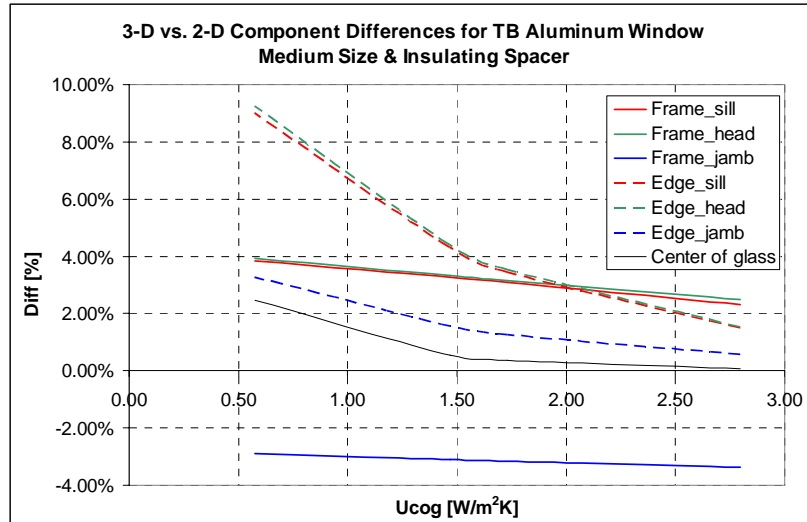

**Figure 6.5-11: Component Level Difference Graphs for Medium Size T/B AL Window**

**Table 6.5-34: T/B AL Window – Small Size, Insulating Spacer (Conduction Model)**

<b>DbI Clear</b>		<b>Spacer keff = 0.050 W/mK</b>					
<b>Section</b>	<b>T5/W5</b>	<b>2-D</b>	<b>% diff</b>	<b>2-D*</b>	<b>% diff</b>	<b>3-D</b>	<b>% diff</b>
	<b>W/m<sup>2</sup>K</b>	<b>W/m<sup>2</sup>K</b>	<b>2D vs T5/W5</b>	<b>W/m<sup>2</sup>K</b>	<b>2D* vs T5/W5</b>	<b>W/m<sup>2</sup>K</b>	<b>3D vs 2-D</b>
Frame_sill	5.02	4.83	-3.88%	5.14	2.33%	4.98	2.94%
Frame_head	4.99	4.83	-3.40%	5.13	2.64%	4.97	2.83%
Frame_jamb	5.38	5.21	-3.26%	5.16	-4.28%	5.15	-1.12%
Center of glass	2.80	2.80	-0.02%	2.79	-0.10%	2.79	-0.02%
Edge_sill	2.87	2.85	-0.65%	2.87	-0.10%	2.88	0.87%
Edge_head	2.87	2.85	-0.62%	2.87	-0.01%	2.88	0.91%
Edge_jamb	2.90	2.88	-0.58%	2.88	-0.60%	2.89	0.30%
<b>TOTAL</b>	<b>3.57</b>	<b>3.52</b>	<b>-1.58%</b>	<b>3.54</b>	<b>-0.80%</b>	<b>3.52</b>	<b>0.24%</b>
<b>DbI Low-e HC</b>		<b>Spacer keff = 0.050 W/mK</b>					
<b>Section</b>	<b>T5/W5</b>	<b>2-D</b>	<b>% diff</b>	<b>2-D*</b>	<b>% diff</b>	<b>3-D</b>	<b>% diff</b>
	<b>W/m<sup>2</sup>K</b>	<b>W/m<sup>2</sup>K</b>	<b>2D vs T5/W5</b>	<b>W/m<sup>2</sup>K</b>	<b>2D* vs T5/W5</b>	<b>W/m<sup>2</sup>K</b>	<b>3D vs 2-D</b>
Frame_sill	4.83	4.65	-3.92%	4.98	3.01%	4.83	3.83%
Frame_head	4.83	4.65	-3.82%	4.97	2.87%	4.83	3.65%
Frame_jamb	5.19	5.04	-2.91%	5.00	-3.74%	5.00	-0.77%
Center of glass	1.73	1.75	0.90%	1.75	0.85%	1.75	0.27%
Edge_sill	2.00	1.99	-0.49%	2.00	0.45%	2.04	2.69%
Edge_head	2.00	1.99	-0.53%	2.01	0.47%	2.04	2.74%
Edge_jamb	2.03	2.02	-0.30%	2.02	-0.39%	2.05	1.03%
<b>TOTAL</b>	<b>2.83</b>	<b>2.79</b>	<b>-1.53%</b>	<b>2.82</b>	<b>-0.36%</b>	<b>2.81</b>	<b>0.85%</b>
<b>DbI Low-e SC</b>		<b>Spacer keff = 0.050 W/mK</b>					
<b>Section</b>	<b>T5/W5</b>	<b>2-D</b>	<b>% diff</b>	<b>2-D*</b>	<b>% diff</b>	<b>3-D</b>	<b>% diff</b>
	<b>W/m<sup>2</sup>K</b>	<b>W/m<sup>2</sup>K</b>	<b>2D vs T5/W5</b>	<b>W/m<sup>2</sup>K</b>	<b>2D* vs T5/W5</b>	<b>W/m<sup>2</sup>K</b>	<b>3D vs 2-D</b>
Frame_sill	4.79	4.62	-3.76%	4.89	2.06%	4.75	2.83%
Frame_head	4.79	4.61	-3.88%	4.89	2.00%	4.75	2.90%
Frame_jamb	5.16	5.00	-3.18%	4.92	-4.72%	4.93	-1.46%
Center of glass	1.47	1.46	-0.44%	1.46	-0.49%	1.47	0.45%
Edge_sill	1.79	1.76	-1.53%	1.77	-0.58%	1.82	3.28%
Edge_head	1.79	1.76	-1.62%	1.77	-0.58%	1.82	3.37%
Edge_jamb	1.82	1.80	-1.41%	1.79	-1.63%	1.82	1.22%
<b>TOTAL</b>	<b>2.65</b>	<b>2.59</b>	<b>-2.27%</b>	<b>2.61</b>	<b>-1.50%</b>	<b>2.61</b>	<b>0.53%</b>

**Table 6.5-35: T/B AL Window – Small Size, Medium Conducting Spacer  
(Conduction Model)**

<b>Dbi Clear</b>	<b>Spacer keff = 0.674</b>		<b>W/mK</b>				
<b>Section</b>	<b>T5/W5</b>	<b>2-D</b>	<b>% diff</b>	<b>2-D*</b>	<b>% diff</b>	<b>3-D</b>	<b>% diff</b>
	<b>W/m<sup>2</sup>K</b>	<b>W/m<sup>2</sup>K</b>	<b>2D vs T5/W5</b>	<b>W/m<sup>2</sup>K</b>	<b>2D* vs T5/W5</b>	<b>W/m<sup>2</sup>K</b>	<b>3D vs 2-D</b>
Frame_sill	5.35	5.22	-2.48%	5.50	2.67%	5.31	1.70%
Frame_head	5.35	5.22	-2.47%	5.50	2.72%	5.32	1.75%
Frame_jamb	5.69	5.57	-2.03%	5.50	-3.31%	5.49	-1.53%
Center of glass	2.80	2.80	0.04%	2.79	-0.04%	2.80	0.07%
Edge_sill	3.05	3.04	-0.51%	3.05	-0.27%	3.07	1.13%
Edge_head	3.05	3.04	-0.50%	3.05	-0.23%	3.07	1.16%
Edge_jamb	3.07	3.05	-0.46%	3.05	-0.66%	3.07	0.51%
<b>TOTAL</b>	<b>3.72</b>	<b>3.68</b>	<b>-1.02%</b>	<b>3.70</b>	<b>-0.50%</b>	<b>3.68</b>	<b>0.01%</b>
<b>Dbi Low-e HC</b>	<b>Spacer keff = 0.674</b>		<b>W/mK</b>				
<b>Section</b>	<b>T5/W5</b>	<b>2-D</b>	<b>% diff</b>	<b>2-D*</b>	<b>% diff</b>	<b>3-D</b>	<b>% diff</b>
	<b>W/m<sup>2</sup>K</b>	<b>W/m<sup>2</sup>K</b>	<b>2D vs T5/W5</b>	<b>W/m<sup>2</sup>K</b>	<b>2D* vs T5/W5</b>	<b>W/m<sup>2</sup>K</b>	<b>3D vs 2-D</b>
Frame_sill	5.22	5.11	-2.08%	5.39	3.17%	5.22	1.94%
Frame_head	5.23	5.11	-2.25%	5.40	3.19%	5.22	2.12%
Frame_jamb	5.57	5.46	-1.91%	5.40	-3.06%	5.39	-1.32%
Center of glass	1.73	1.75	1.07%	1.75	1.00%	1.76	0.52%
Edge_sill	2.25	2.24	-0.35%	2.24	-0.15%	2.30	2.74%
Edge_head	2.25	2.24	-0.36%	2.25	-0.08%	2.30	2.81%
Edge_jamb	2.26	2.26	-0.30%	2.25	-0.73%	2.28	1.22%
<b>TOTAL</b>	<b>3.01</b>	<b>2.99</b>	<b>-0.83%</b>	<b>3.01</b>	<b>-0.14%</b>	<b>3.00</b>	<b>0.42%</b>
<b>Dbi Low-e SC</b>	<b>Spacer keff = 0.674</b>		<b>W/mK</b>				
<b>Section</b>	<b>T5/W5</b>	<b>2-D</b>	<b>% diff</b>	<b>2-D*</b>	<b>% diff</b>	<b>3-D</b>	<b>% diff</b>
	<b>W/m<sup>2</sup>K</b>	<b>W/m<sup>2</sup>K</b>	<b>2D vs T5/W5</b>	<b>W/m<sup>2</sup>K</b>	<b>2D* vs T5/W5</b>	<b>W/m<sup>2</sup>K</b>	<b>3D vs 2-D</b>
Frame_sill	5.20	5.09	-2.15%	5.39	3.63%	5.22	2.49%
Frame_head	5.20	5.08	-2.26%	5.41	3.83%	5.23	2.80%
Frame_jamb	5.54	5.44	-1.99%	5.40	-2.66%	5.39	-0.80%
Center of glass	1.47	1.46	-0.22%	1.46	-0.28%	1.48	0.79%
Edge_sill	2.05	2.03	-1.23%	2.03	-1.01%	2.10	3.45%
Edge_head	2.05	2.03	-1.26%	2.03	-0.94%	2.10	3.54%
Edge_jamb	2.07	2.04	-1.19%	2.04	-1.67%	2.08	1.59%
<b>TOTAL</b>	<b>2.84</b>	<b>2.80</b>	<b>-1.42%</b>	<b>2.83</b>	<b>-0.37%</b>	<b>2.83</b>	<b>0.88%</b>

**Table 6.5-36: T/B AL Window – Small Size, Highly Conducting Spacer (Conduction Model)**

<b>DbI Clear</b>		<b>Spacer keff = 1.900</b>		<b>W/mK</b>			
<b>Section</b>	<b>T5/W5</b>	<b>2-D</b>	<b>% diff</b>	<b>2-D*</b>	<b>% diff</b>	<b>3-D</b>	<b>% diff</b>
	<b>W/m<sup>2</sup>K</b>	<b>W/m<sup>2</sup>K</b>	<b>2D vs T5/W5</b>	<b>W/m<sup>2</sup>K</b>	<b>2D* vs T5/W5</b>	<b>W/m<sup>2</sup>K</b>	<b>3D vs 2-D</b>
Frame_sill	5.52	5.39	-2.40%	5.65	2.21%	5.45	1.05%
Frame_head	5.51	5.40	-2.10%	5.65	2.49%	5.45	1.04%
Frame_jamb	5.85	5.74	-1.92%	5.66	-3.44%	5.63	-1.88%
Center of glass	2.80	2.80	0.06%	2.80	-0.01%	2.80	0.12%
Edge_sill	3.15	3.12	-0.71%	3.13	-0.56%	3.16	1.28%
Edge_head	3.14	3.12	-0.67%	3.13	-0.49%	3.16	1.30%
Edge_jamb	3.15	3.13	-0.63%	3.13	-0.86%	3.15	0.62%
<b>TOTAL</b>	<b>3.79</b>	<b>3.76</b>	<b>-1.01%</b>	<b>3.77</b>	<b>-0.67%</b>	<b>3.75</b>	<b>-0.17%</b>

<b>DbI Low-e HC</b>		<b>Spacer keff = 1.900</b>		<b>W/mK</b>			
<b>Section</b>	<b>T5/W5</b>	<b>2-D</b>	<b>% diff</b>	<b>2-D*</b>	<b>% diff</b>	<b>3-D</b>	<b>% diff</b>
	<b>W/m<sup>2</sup>K</b>	<b>W/m<sup>2</sup>K</b>	<b>2D vs T5/W5</b>	<b>W/m<sup>2</sup>K</b>	<b>2D* vs T5/W5</b>	<b>W/m<sup>2</sup>K</b>	<b>3D vs 2-D</b>
Frame_sill	5.42	5.31	-2.06%	5.58	2.92%	5.39	1.52%
Frame_head	5.41	5.31	-1.91%	5.59	3.22%	5.40	1.68%
Frame_jamb	5.76	5.65	-1.82%	5.59	-2.99%	5.57	-1.44%
Center of glass	1.73	1.75	1.13%	1.75	1.07%	1.76	0.64%
Edge_sill	2.37	2.35	-0.74%	2.35	-0.58%	2.42	2.94%
Edge_head	2.36	2.35	-0.71%	2.35	-0.60%	2.42	3.00%
Edge_jamb	2.38	2.36	-0.69%	2.35	-1.12%	2.39	1.42%
<b>TOTAL</b>	<b>3.10</b>	<b>3.08</b>	<b>-0.84%</b>	<b>3.10</b>	<b>-0.22%</b>	<b>3.09</b>	<b>0.37%</b>

<b>DbI Low-e SC</b>		<b>Spacer keff = 1.900</b>		<b>W/mK</b>			
<b>Section</b>	<b>T5/W5</b>	<b>2-D</b>	<b>% diff</b>	<b>2-D*</b>	<b>% diff</b>	<b>3-D</b>	<b>% diff</b>
	<b>W/m<sup>2</sup>K</b>	<b>W/m<sup>2</sup>K</b>	<b>2D vs T5/W5</b>	<b>W/m<sup>2</sup>K</b>	<b>2D* vs T5/W5</b>	<b>W/m<sup>2</sup>K</b>	<b>3D vs 2-D</b>
Frame_sill	5.40	5.29	-2.11%	5.57	2.95%	5.38	1.62%
Frame_head	5.39	5.28	-1.95%	5.57	3.32%	5.38	1.84%
Frame_jamb	5.74	5.63	-1.90%	5.57	-2.98%	5.56	-1.34%
Center of glass	1.47	1.47	-0.12%	1.47	-0.18%	1.48	0.95%
Edge_sill	2.18	2.14	-1.64%	2.14	-1.58%	2.22	3.60%
Edge_head	2.18	2.14	-1.67%	2.14	-1.50%	2.22	3.69%
Edge_jamb	2.19	2.15	-1.62%	2.14	-2.12%	2.19	1.76%
<b>TOTAL</b>	<b>2.93</b>	<b>2.89</b>	<b>-1.41%</b>	<b>2.91</b>	<b>-0.69%</b>	<b>2.91</b>	<b>0.55%</b>

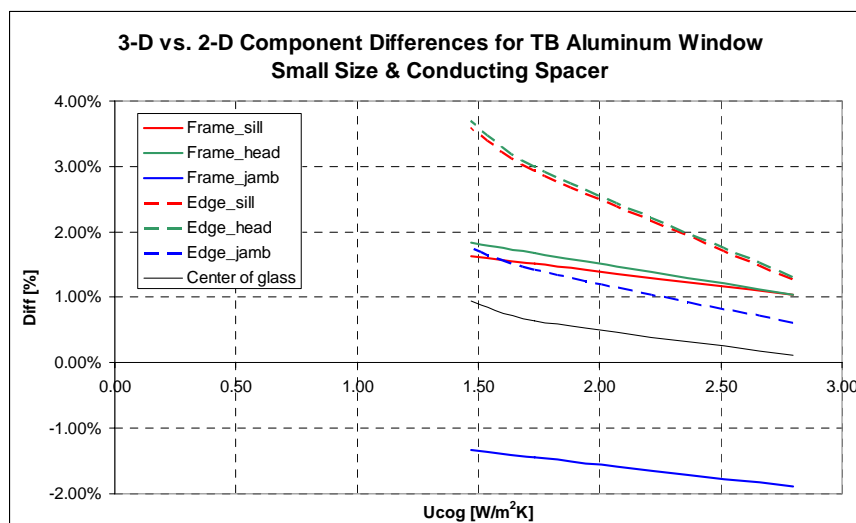
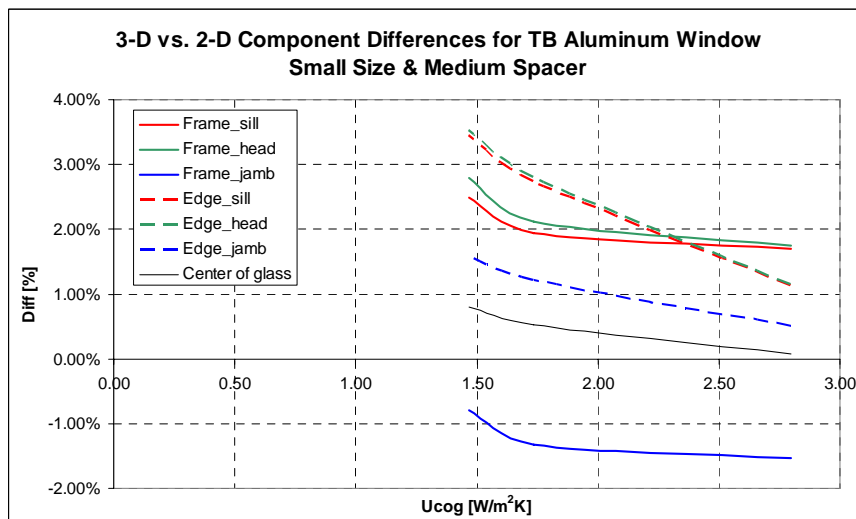
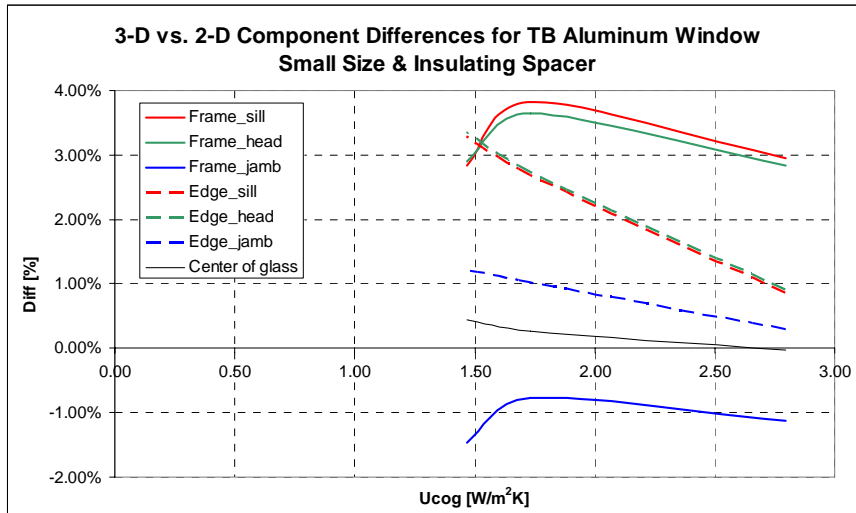

Figure 6.5-12: Component Level Difference Graphs for Small Size T/B AL Window

### 6.5.7 Component level results and comparisons for AL window (conduction models)

**Table 6.5-37: AL Window – Large Size, Insulating Spacer (Conduction Model)**

Dbi Clear		Spacer keff = 0.050			W/mK		
Section	T5/W5	2-D	% diff	2-D*	% diff	3-D	% diff
	W/m <sup>2</sup> K	W/m <sup>2</sup> K	2D vs T5/W5	W/m <sup>2</sup> K	2D* vs T5/W5	W/m <sup>2</sup> K	3D vs 2-D
Frame_sill	8.80	8.75	-0.51%	8.88	0.90%	8.53	-2.62%
Frame_head	8.80	8.75	-0.58%	8.88	0.90%	8.53	-2.54%
Frame_jamb	8.80	8.77	-0.36%	8.61	-2.16%	8.71	-0.65%
Center of glass	2.80	2.80	-0.02%	2.79	-0.07%	2.80	0.15%
Edge_sill	3.08	3.11	1.03%	3.12	1.33%	3.16	1.72%
Edge_head	3.08	3.11	0.96%	3.12	1.28%	3.16	1.76%
Edge_jamb	3.08	3.12	1.26%	3.12	1.30%	3.14	0.55%
<b>TOTAL</b>	<b>4.47</b>	<b>4.47</b>	<b>0.02%</b>	<b>4.45</b>	<b>-0.44%</b>	<b>4.45</b>	<b>-0.42%</b>
Dbi Low-e HC		Spacer keff = 0.050			W/mK		
Section	T5/W5	2-D	% diff	2-D*	% diff	3-D	% diff
	W/m <sup>2</sup> K	W/m <sup>2</sup> K	2D vs T5/W5	W/m <sup>2</sup> K	2D* vs T5/W5	W/m <sup>2</sup> K	3D vs 2-D
Frame_sill	8.72	8.67	-0.49%	8.79	0.84%	8.45	-2.63%
Frame_head	8.72	8.66	-0.66%	8.79	0.82%	8.45	-2.47%
Frame_jamb	8.72	8.69	-0.31%	8.52	-2.27%	8.63	-0.75%
Center of glass	1.73	1.75	0.90%	1.75	0.88%	1.76	0.65%
Edge_sill	2.24	2.30	2.58%	2.31	3.02%	2.39	3.60%
Edge_head	2.24	2.30	2.42%	2.31	2.94%	2.39	3.69%
Edge_jamb	2.25	2.32	3.02%	2.32	3.07%	2.34	1.15%
<b>TOTAL</b>	<b>3.72</b>	<b>3.74</b>	<b>0.45%</b>	<b>3.72</b>	<b>-0.15%</b>	<b>3.73</b>	<b>-0.34%</b>
Dbi Low-e SC		Spacer keff = 0.050			W/mK		
Section	T5/W5	2-D	% diff	2-D*	% diff	3-D	% diff
	W/m <sup>2</sup> K	W/m <sup>2</sup> K	2D vs T5/W5	W/m <sup>2</sup> K	2D* vs T5/W5	W/m <sup>2</sup> K	3D vs 2-D
Frame_sill	8.70	8.65	-0.50%	8.77	0.83%	8.43	-2.62%
Frame_head	8.70	8.64	-0.63%	8.77	0.82%	8.43	-2.49%
Frame_jamb	8.70	8.67	-0.32%	8.50	-2.29%	8.61	-0.75%
Center of glass	1.47	1.46	-0.45%	1.46	-0.45%	1.48	0.97%
Edge_sill	2.04	2.09	2.27%	2.10	2.80%	2.18	4.38%
Edge_head	2.04	2.08	2.11%	2.10	2.69%	2.18	4.47%
Edge_jamb	2.04	2.10	2.77%	2.10	2.85%	2.13	1.42%
<b>TOTAL</b>	<b>3.54</b>	<b>3.54</b>	<b>0.09%</b>	<b>3.52</b>	<b>-0.56%</b>	<b>3.53</b>	<b>-0.28%</b>
Hypothetical R10		Spacer keff = 0.050			W/mK		
Section	T5/W5	2-D	% diff	2-D*	% diff	3-D	% diff
	W/m <sup>2</sup> K	W/m <sup>2</sup> K	2D vs T5/W5	W/m <sup>2</sup> K	2D* vs T5/W5	W/m <sup>2</sup> K	3D vs 2-D
Frame_sill	8.61	8.59	-0.19%	8.71	1.21%	8.38	-2.48%
Frame_head	8.61	8.58	-0.27%	8.71	1.19%	8.38	-2.42%
Frame_jamb	8.57	8.60	0.36%	8.44	-1.45%	8.55	-0.56%
Center of glass	0.58	0.58	0.78%	0.58	0.83%	0.60	3.87%
Edge_sill	1.40	1.44	2.77%	1.45	3.60%	1.57	8.04%
Edge_head	1.40	1.44	2.53%	1.45	3.42%	1.57	8.15%
Edge_jamb	1.39	1.46	4.68%	1.46	4.82%	1.50	2.67%
<b>TOTAL</b>	<b>2.91</b>	<b>2.94</b>	<b>0.80%</b>	<b>2.92</b>	<b>0.14%</b>	<b>2.94</b>	<b>0.05%</b>

**Table 6.5-38: AL Window – Large Size, Medium Conducting Spacer (Conduction Model)**

<b>Dbi Clear</b>		<b>Spacer keff = 0.674</b>		<b>W/mK</b>			
<b>Section</b>	<b>T5/W5</b>	<b>2-D</b>	<b>% diff</b>	<b>2-D*</b>	<b>% diff</b>	<b>3-D</b>	<b>% diff</b>
	<b>W/m<sup>2</sup>K</b>	<b>W/m<sup>2</sup>K</b>	<b>2D vs T5/W5</b>	<b>W/m<sup>2</sup>K</b>	<b>2D* vs T5/W5</b>	<b>W/m<sup>2</sup>K</b>	<b>3D vs 2-D</b>
Frame_sill	8.86	8.81	-0.55%	8.94	0.97%	8.59	-2.54%
Frame_head	8.86	8.80	-0.69%	8.94	0.96%	8.59	-2.41%
Frame_jamb	8.86	8.82	-0.47%	8.68	-2.09%	8.77	-0.49%
Center of glass	2.80	2.80	-0.01%	2.80	-0.03%	2.80	0.22%
Edge_sill	3.19	3.20	0.21%	3.21	0.51%	3.26	1.92%
Edge_head	3.19	3.19	0.15%	3.21	0.47%	3.26	1.95%
Edge_jamb	3.19	3.20	0.29%	3.20	0.35%	3.22	0.65%
<b>TOTAL</b>	<b>4.51</b>	<b>4.50</b>	<b>-0.18%</b>	<b>4.49</b>	<b>-0.54%</b>	<b>4.49</b>	<b>-0.30%</b>
<b>Dbi Low-e HC</b>							
<b>Spacer keff = 0.674</b>		<b>W/mK</b>					
<b>Section</b>	<b>T5/W5</b>	<b>2-D</b>	<b>% diff</b>	<b>2-D*</b>	<b>% diff</b>	<b>3-D</b>	<b>% diff</b>
	<b>W/m<sup>2</sup>K</b>	<b>W/m<sup>2</sup>K</b>	<b>2D vs T5/W5</b>	<b>W/m<sup>2</sup>K</b>	<b>2D* vs T5/W5</b>	<b>W/m<sup>2</sup>K</b>	<b>3D vs 2-D</b>
Frame_sill	8.79	8.74	-0.63%	8.86	0.74%	8.51	-2.64%
Frame_head	8.79	8.72	-0.81%	8.86	0.73%	8.51	-2.48%
Frame_jamb	8.80	8.75	-0.52%	8.59	-2.39%	8.69	-0.69%
Center of glass	1.73	1.75	0.95%	1.75	0.92%	1.76	0.78%
Edge_sill	2.41	2.42	0.76%	2.43	1.19%	2.52	3.81%
Edge_head	2.41	2.42	0.65%	2.43	1.13%	2.52	3.87%
Edge_jamb	2.41	2.43	0.94%	2.43	1.02%	2.46	1.27%
<b>TOTAL</b>	<b>3.78</b>	<b>3.79</b>	<b>0.05%</b>	<b>3.76</b>	<b>-0.51%</b>	<b>3.78</b>	<b>-0.25%</b>
<b>Dbi Low-e SC</b>							
<b>Spacer keff = 0.674</b>		<b>W/mK</b>					
<b>Section</b>	<b>T5/W5</b>	<b>2-D</b>	<b>% diff</b>	<b>2-D*</b>	<b>% diff</b>	<b>3-D</b>	<b>% diff</b>
	<b>W/m<sup>2</sup>K</b>	<b>W/m<sup>2</sup>K</b>	<b>2D vs T5/W5</b>	<b>W/m<sup>2</sup>K</b>	<b>2D* vs T5/W5</b>	<b>W/m<sup>2</sup>K</b>	<b>3D vs 2-D</b>
Frame_sill	8.78	8.72	-0.64%	8.86	0.95%	8.52	-2.41%
Frame_head	8.78	8.71	-0.79%	8.86	0.95%	8.52	-2.26%
Frame_jamb	8.78	8.73	-0.55%	8.59	-2.17%	8.69	-0.43%
Center of glass	1.47	1.46	-0.39%	1.46	-0.41%	1.48	1.13%
Edge_sill	2.22	2.22	0.15%	2.23	0.65%	2.32	4.57%
Edge_head	2.22	2.22	0.03%	2.23	0.58%	2.32	4.63%
Edge_jamb	2.22	2.22	0.30%	2.23	0.43%	2.26	1.57%
<b>TOTAL</b>	<b>3.61</b>	<b>3.59</b>	<b>-0.39%</b>	<b>3.58</b>	<b>-0.81%</b>	<b>3.59</b>	<b>-0.02%</b>
<b>Hypothetical R10</b>							
<b>Spacer keff = 0.674</b>		<b>W/mK</b>					
<b>Section</b>	<b>T5/W5</b>	<b>2-D</b>	<b>% diff</b>	<b>2-D*</b>	<b>% diff</b>	<b>3-D</b>	<b>% diff</b>
	<b>W/m<sup>2</sup>K</b>	<b>W/m<sup>2</sup>K</b>	<b>2D vs T5/W5</b>	<b>W/m<sup>2</sup>K</b>	<b>2D* vs T5/W5</b>	<b>W/m<sup>2</sup>K</b>	<b>3D vs 2-D</b>
Frame_sill	8.70	8.67	-0.37%	8.79	1.00%	8.45	-2.59%
Frame_head	8.70	8.66	-0.46%	8.79	0.98%	8.45	-2.52%
Frame_jamb	8.70	8.67	-0.35%	8.52	-2.17%	8.62	-0.60%
Center of glass	0.58	0.58	0.99%	0.58	1.05%	0.61	4.48%
Edge_sill	1.62	1.60	-1.23%	1.62	-0.44%	1.74	7.94%
Edge_head	1.62	1.60	-1.36%	1.61	-0.56%	1.74	7.98%
Edge_jamb	1.63	1.61	-0.89%	1.61	-0.72%	1.66	2.72%
<b>TOTAL</b>	<b>3.00</b>	<b>3.00</b>	<b>-0.27%</b>	<b>2.98</b>	<b>-0.93%</b>	<b>3.00</b>	<b>0.11%</b>



**Table 6.5-39: AL Window – Large Size, Highly Conducting Spacer (Conduction Model)**

<b>Dbf Clear</b>	<b>Spacer keff =</b>		<b>1.900 W/mK</b>				
<b>Section</b>	<b>T5/W5</b>	<b>2-D</b>	<b>% diff</b>	<b>2-D*</b>	<b>% diff</b>	<b>3-D</b>	<b>% diff</b>
	<b>W/m<sup>2</sup>K</b>	<b>W/m<sup>2</sup>K</b>	<b>2D vs T5/W5</b>	<b>W/m<sup>2</sup>K</b>	<b>2D* vs T5/W5</b>	<b>W/m<sup>2</sup>K</b>	<b>3D vs 2-D</b>
Frame_sill	8.89	8.82	-0.70%	8.97	0.95%	8.61	-2.44%
Frame_head	8.89	8.83	-0.57%	8.97	0.95%	8.61	-2.57%
Frame_jamb	8.89	8.84	-0.48%	8.70	-2.10%	8.80	-0.51%
Center of glass	2.80	2.80	0.00%	2.80	-0.02%	2.80	0.24%
Edge_sill	3.25	3.24	-0.24%	3.25	0.07%	3.31	2.02%
Edge_head	3.25	3.24	-0.29%	3.25	0.03%	3.31	2.04%
Edge_jamb	3.25	3.24	-0.27%	3.24	-0.20%	3.26	0.69%
<b>TOTAL</b>	<b>4.53</b>	<b>4.52</b>	<b>-0.28%</b>	<b>4.50</b>	<b>-0.64%</b>	<b>4.51</b>	<b>-0.29%</b>
<b>Dbf Low-e HC</b>	<b>Spacer keff =</b>		<b>1.900 W/mK</b>				
<b>Section</b>	<b>T5/W5</b>	<b>2-D</b>	<b>% diff</b>	<b>2-D*</b>	<b>% diff</b>	<b>3-D</b>	<b>% diff</b>
	<b>W/m<sup>2</sup>K</b>	<b>W/m<sup>2</sup>K</b>	<b>2D vs T5/W5</b>	<b>W/m<sup>2</sup>K</b>	<b>2D* vs T5/W5</b>	<b>W/m<sup>2</sup>K</b>	<b>3D vs 2-D</b>
Frame_sill	8.83	8.77	-0.68%	8.89	0.70%	8.54	-2.68%
Frame_head	8.83	8.76	-0.84%	8.89	0.69%	8.54	-2.53%
Frame_jamb	8.83	8.78	-0.57%	8.62	-2.43%	8.72	-0.71%
Center of glass	1.73	1.75	0.96%	1.75	0.94%	1.76	0.85%
Edge_sill	2.48	2.48	0.04%	2.49	0.50%	2.58	3.93%
Edge_head	2.48	2.48	-0.01%	2.49	0.48%	2.58	3.97%
Edge_jamb	2.48	2.48	0.13%	2.49	0.23%	2.52	1.33%
<b>TOTAL</b>	<b>3.81</b>	<b>3.81</b>	<b>-0.09%</b>	<b>3.79</b>	<b>-0.64%</b>	<b>3.80</b>	<b>-0.23%</b>
<b>Dbf Low-e SC</b>	<b>Spacer keff =</b>		<b>1.900 W/mK</b>				
<b>Section</b>	<b>T5/W5</b>	<b>2-D</b>	<b>% diff</b>	<b>2-D*</b>	<b>% diff</b>	<b>3-D</b>	<b>% diff</b>
	<b>W/m<sup>2</sup>K</b>	<b>W/m<sup>2</sup>K</b>	<b>2D vs T5/W5</b>	<b>W/m<sup>2</sup>K</b>	<b>2D* vs T5/W5</b>	<b>W/m<sup>2</sup>K</b>	<b>3D vs 2-D</b>
Frame_sill	8.82	8.76	-0.68%	8.87	0.62%	8.52	-2.75%
Frame_head	8.82	8.74	-0.84%	8.87	0.61%	8.52	-2.60%
Frame_jamb	8.82	8.77	-0.56%	8.60	-2.53%	8.70	-0.80%
Center of glass	1.47	1.46	-0.36%	1.46	-0.38%	1.48	1.21%
Edge_sill	2.30	2.28	-0.66%	2.29	-0.17%	2.39	4.65%
Edge_head	2.30	2.28	-0.75%	2.29	-0.23%	2.39	4.69%
Edge_jamb	2.30	2.28	-0.56%	2.29	-0.45%	2.32	1.58%
<b>TOTAL</b>	<b>3.63</b>	<b>3.62</b>	<b>-0.51%</b>	<b>3.59</b>	<b>-1.15%</b>	<b>3.61</b>	<b>-0.22%</b>
<b>Hypothetical R10</b>	<b>Spacer keff =</b>		<b>1.900 W/mK</b>				
<b>Section</b>	<b>T5/W5</b>	<b>2-D</b>	<b>% diff</b>	<b>2-D*</b>	<b>% diff</b>	<b>3-D</b>	<b>% diff</b>
	<b>W/m<sup>2</sup>K</b>	<b>W/m<sup>2</sup>K</b>	<b>2D vs T5/W5</b>	<b>W/m<sup>2</sup>K</b>	<b>2D* vs T5/W5</b>	<b>W/m<sup>2</sup>K</b>	<b>3D vs 2-D</b>
Frame_sill	8.75	8.71	-0.40%	8.83	0.95%	8.49	-2.65%
Frame_head	8.75	8.70	-0.54%	8.83	0.92%	8.49	-2.55%
Frame_jamb	8.75	8.71	-0.41%	8.56	-2.24%	8.66	-0.64%
Center of glass	0.58	0.58	1.08%	0.58	1.15%	0.61	4.77%
Edge_sill	1.72	1.68	-2.70%	1.69	-1.89%	1.82	7.95%
Edge_head	1.72	1.68	-2.82%	1.69	-1.99%	1.82	7.99%
Edge_jamb	1.72	1.68	-2.49%	1.69	-2.27%	1.73	2.77%
<b>TOTAL</b>	<b>3.04</b>	<b>3.02</b>	<b>-0.52%</b>	<b>3.00</b>	<b>-1.18%</b>	<b>3.03</b>	<b>0.14%</b>

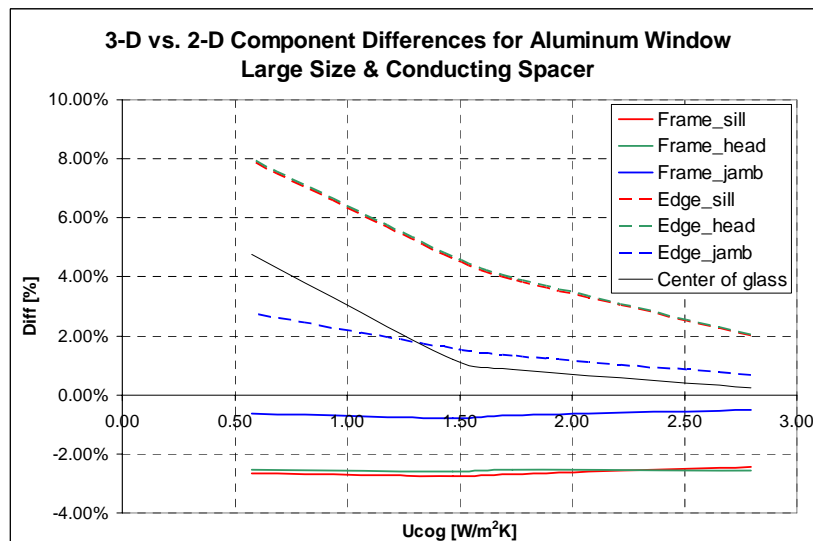
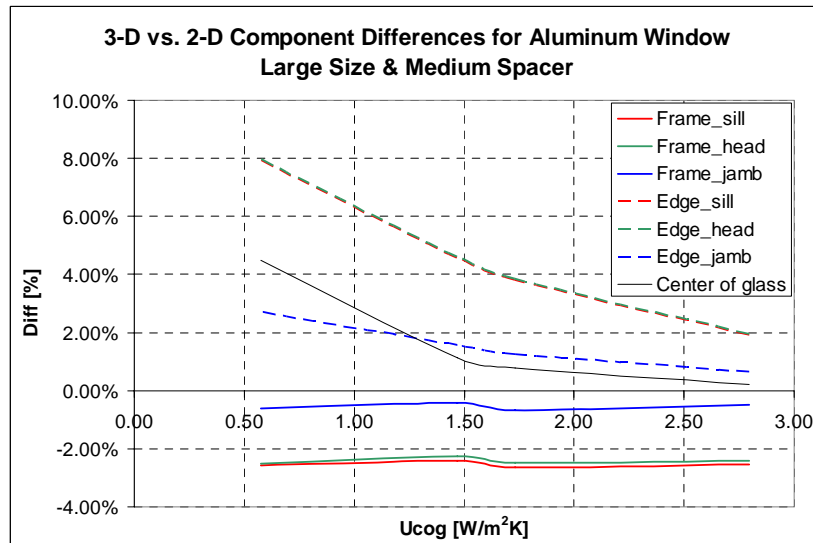
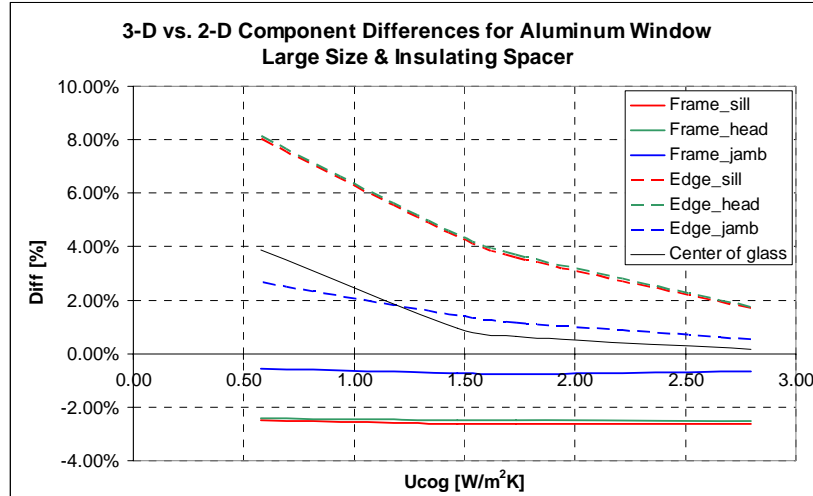

Figure 6.5-13: Component Level Difference Graphs for Large Size AL Window

**Table 6.5-40: AL Window – Medium Size, Insulating Spacer (Conduction Model)**

<b>Dbi Clear</b>		<b>Spacer keff = 0.050</b>		<b>W/mK</b>			
<b>Section</b>	<b>T5/W5</b>	<b>2-D</b>	<b>% diff</b>	<b>2-D*</b>	<b>% diff</b>	<b>3-D</b>	<b>% diff</b>
	<b>W/m<sup>2</sup>K</b>	<b>W/m<sup>2</sup>K</b>	<b>2D vs T5/W5</b>	<b>W/m<sup>2</sup>K</b>	<b>2D* vs T5/W5</b>	<b>W/m<sup>2</sup>K</b>	<b>3D vs 2-D</b>
Frame_sill	8.80	8.76	-0.48%	8.89	1.09%	8.54	-2.56%
Frame_head	8.80	8.75	-0.57%	8.89	1.09%	8.54	-2.46%
Frame_jamb	8.80	8.76	-0.44%	8.65	-1.77%	8.48	-3.29%
Center of glass	2.80	2.79	-0.05%	2.79	-0.04%	2.80	0.20%
Edge_sill	3.08	3.11	1.04%	3.12	1.47%	3.17	1.87%
Edge_head	3.08	3.11	0.96%	3.12	1.46%	3.17	1.96%
Edge_jamb	3.08	3.12	1.26%	3.13	1.54%	3.15	0.88%
<b>TOTAL</b>	<b>4.57</b>	<b>4.57</b>	<b>-0.01%</b>	<b>4.56</b>	<b>-0.15%</b>	<b>4.51</b>	<b>-1.38%</b>
<b>Dbi Low-e HC</b>							
<b>Spacer keff = 0.050</b>		<b>W/mK</b>					
<b>Section</b>	<b>T5/W5</b>	<b>2-D</b>	<b>% diff</b>	<b>2-D*</b>	<b>% diff</b>	<b>3-D</b>	<b>% diff</b>
	<b>W/m<sup>2</sup>K</b>	<b>W/m<sup>2</sup>K</b>	<b>2D vs T5/W5</b>	<b>W/m<sup>2</sup>K</b>	<b>2D* vs T5/W5</b>	<b>W/m<sup>2</sup>K</b>	<b>3D vs 2-D</b>
Frame_sill	8.72	8.67	-0.48%	8.82	1.16%	8.47	-2.41%
Frame_head	8.72	8.67	-0.57%	8.82	1.16%	8.47	-2.32%
Frame_jamb	8.72	8.68	-0.45%	8.57	-1.73%	8.41	-3.19%
Center of glass	1.73	1.75	0.92%	1.75	0.94%	1.76	0.68%
Edge_sill	2.24	2.30	2.58%	2.32	3.18%	2.39	3.77%
Edge_head	2.24	2.30	2.45%	2.32	3.18%	2.39	3.92%
Edge_jamb	2.25	2.32	3.01%	2.33	3.41%	2.36	1.69%
<b>TOTAL</b>	<b>3.84</b>	<b>3.86</b>	<b>0.38%</b>	<b>3.85</b>	<b>0.26%</b>	<b>3.80</b>	<b>-1.35%</b>
<b>Dbi Low-e SC</b>							
<b>Spacer keff = 0.050</b>		<b>W/mK</b>					
<b>Section</b>	<b>T5/W5</b>	<b>2-D</b>	<b>% diff</b>	<b>2-D*</b>	<b>% diff</b>	<b>3-D</b>	<b>% diff</b>
	<b>W/m<sup>2</sup>K</b>	<b>W/m<sup>2</sup>K</b>	<b>2D vs T5/W5</b>	<b>W/m<sup>2</sup>K</b>	<b>2D* vs T5/W5</b>	<b>W/m<sup>2</sup>K</b>	<b>3D vs 2-D</b>
Frame_sill	8.70	8.65	-0.51%	8.80	1.16%	8.45	-2.37%
Frame_head	8.70	8.65	-0.59%	8.80	1.16%	8.43	-2.59%
Frame_jamb	8.70	8.66	-0.47%	8.55	-1.74%	8.39	-3.17%
Center of glass	1.47	1.46	-0.40%	1.46	-0.38%	1.48	0.97%
Edge_sill	2.04	2.09	2.26%	2.10	2.93%	2.19	4.54%
Edge_head	2.04	2.08	2.11%	2.10	2.93%	2.19	4.72%
Edge_jamb	2.04	2.10	2.74%	2.11	3.19%	2.14	2.02%
<b>TOTAL</b>	<b>3.66</b>	<b>3.66</b>	<b>0.01%</b>	<b>3.66</b>	<b>-0.10%</b>	<b>3.61</b>	<b>-1.37%</b>
<b>Hypothetical R10</b>							
<b>Spacer keff = 0.050</b>		<b>W/mK</b>					
<b>Section</b>	<b>T5/W5</b>	<b>2-D</b>	<b>% diff</b>	<b>2-D*</b>	<b>% diff</b>	<b>3-D</b>	<b>% diff</b>
	<b>W/m<sup>2</sup>K</b>	<b>W/m<sup>2</sup>K</b>	<b>2D vs T5/W5</b>	<b>W/m<sup>2</sup>K</b>	<b>2D* vs T5/W5</b>	<b>W/m<sup>2</sup>K</b>	<b>3D vs 2-D</b>
Frame_sill	8.61	8.59	-0.18%	8.74	1.54%	8.40	-2.26%
Frame_head	8.61	8.58	-0.27%	8.74	1.54%	8.40	-2.15%
Frame_jamb	8.57	8.60	0.37%	8.49	-0.88%	8.34	-3.12%
Center of glass	0.58	0.58	1.09%	0.58	1.20%	0.61	3.83%
Edge_sill	1.40	1.44	2.77%	1.46	3.75%	1.57	8.18%
Edge_head	1.40	1.44	2.52%	1.46	3.74%	1.57	8.50%
Edge_jamb	1.39	1.46	4.69%	1.47	5.30%	1.52	3.60%
<b>TOTAL</b>	<b>3.05</b>	<b>3.08</b>	<b>0.79%</b>	<b>3.07</b>	<b>0.68%</b>	<b>3.04</b>	<b>-1.24%</b>

**Table 6.5-41: AL Window – Medium Size, Medium Conducting Spacer (Conduction Model)**

<b>Dbf Clear</b>	<b>Spacer keff = 0.674</b>			<b>W/mK</b>			
<b>Section</b>	<b>T5/W5</b>	<b>2-D</b>	<b>% diff</b>	<b>2-D*</b>	<b>% diff</b>	<b>3-D</b>	<b>% diff</b>
	<b>W/m<sup>2</sup>K</b>	<b>W/m<sup>2</sup>K</b>	<b>2D vs T5/W5</b>	<b>W/m<sup>2</sup>K</b>	<b>2D* vs T5/W5</b>	<b>W/m<sup>2</sup>K</b>	<b>3D vs 2-D</b>
Frame_sill	8.86	8.81	-0.58%	8.95	1.04%	8.59	-2.55%
Frame_head	8.86	8.80	-0.67%	8.95	1.03%	8.59	-2.46%
Frame_jamb	8.86	8.81	-0.57%	8.70	-1.83%	8.53	-3.23%
Center of glass	2.80	2.80	-0.03%	2.80	-0.02%	2.80	0.24%
Edge_sill	3.19	3.20	0.20%	3.21	0.70%	3.27	2.14%
Edge_head	3.19	3.19	0.15%	3.21	0.70%	3.27	2.20%
Edge_jamb	3.19	3.20	0.29%	3.21	0.67%	3.23	1.06%
<b>TOTAL</b>	<b>4.61</b>	<b>4.60</b>	<b>-0.22%</b>	<b>4.60</b>	<b>-0.31%</b>	<b>4.54</b>	<b>-1.31%</b>
<b>Dbf Low-e HC</b>	<b>Spacer keff = 0.674</b>			<b>W/mK</b>			
<b>Section</b>	<b>T5/W5</b>	<b>2-D</b>	<b>% diff</b>	<b>2-D*</b>	<b>% diff</b>	<b>3-D</b>	<b>% diff</b>
	<b>W/m<sup>2</sup>K</b>	<b>W/m<sup>2</sup>K</b>	<b>2D vs T5/W5</b>	<b>W/m<sup>2</sup>K</b>	<b>2D* vs T5/W5</b>	<b>W/m<sup>2</sup>K</b>	<b>3D vs 2-D</b>
Frame_sill	8.79	8.74	-0.62%	8.89	1.07%	8.53	-2.42%
Frame_head	8.79	8.73	-0.71%	8.89	1.07%	8.53	-2.32%
Frame_jamb	8.80	8.74	-0.61%	8.64	-1.83%	8.47	-3.15%
Center of glass	1.73	1.75	0.98%	1.75	1.00%	1.76	0.81%
Edge_sill	2.41	2.42	0.76%	2.44	1.51%	2.53	4.14%
Edge_head	2.41	2.42	0.68%	2.44	1.50%	2.53	4.24%
Edge_jamb	2.41	2.43	0.94%	2.44	1.54%	2.48	2.00%
<b>TOTAL</b>	<b>3.90</b>	<b>3.90</b>	<b>-0.01%</b>	<b>3.90</b>	<b>-0.06%</b>	<b>3.86</b>	<b>-1.23%</b>
<b>Dbf Low-e SC</b>	<b>Spacer keff = 0.674</b>			<b>W/mK</b>			
<b>Section</b>	<b>T5/W5</b>	<b>2-D</b>	<b>% diff</b>	<b>2-D*</b>	<b>% diff</b>	<b>3-D</b>	<b>% diff</b>
	<b>W/m<sup>2</sup>K</b>	<b>W/m<sup>2</sup>K</b>	<b>2D vs T5/W5</b>	<b>W/m<sup>2</sup>K</b>	<b>2D* vs T5/W5</b>	<b>W/m<sup>2</sup>K</b>	<b>3D vs 2-D</b>
Frame_sill	8.78	8.72	-0.67%	8.87	1.05%	8.52	-2.38%
Frame_head	8.78	8.71	-0.74%	8.87	1.07%	8.52	-2.29%
Frame_jamb	8.78	8.72	-0.64%	8.62	-1.85%	8.46	-3.12%
Center of glass	1.47	1.46	-0.33%	1.46	-0.30%	1.48	1.15%
Edge_sill	2.22	2.22	0.12%	2.24	0.98%	2.33	4.92%
Edge_head	2.22	2.22	0.04%	2.24	0.98%	2.33	5.04%
Edge_jamb	2.22	2.22	0.30%	2.24	0.99%	2.28	2.37%
<b>TOTAL</b>	<b>3.73</b>	<b>3.71</b>	<b>-0.41%</b>	<b>3.71</b>	<b>-0.45%</b>	<b>3.67</b>	<b>-1.19%</b>
<b>Hypothetical R10</b>	<b>Spacer keff = 0.674</b>			<b>W/mK</b>			
<b>Section</b>	<b>T5/W5</b>	<b>2-D</b>	<b>% diff</b>	<b>2-D*</b>	<b>% diff</b>	<b>3-D</b>	<b>% diff</b>
	<b>W/m<sup>2</sup>K</b>	<b>W/m<sup>2</sup>K</b>	<b>2D vs T5/W5</b>	<b>W/m<sup>2</sup>K</b>	<b>2D* vs T5/W5</b>	<b>W/m<sup>2</sup>K</b>	<b>3D vs 2-D</b>
Frame_sill	8.70	8.67	-0.38%	8.83	1.42%	8.48	-2.26%
Frame_head	8.70	8.66	-0.46%	8.83	1.42%	8.48	-2.17%
Frame_jamb	8.70	8.67	-0.35%	8.58	-1.50%	8.42	-3.04%
Center of glass	0.58	0.58	1.36%	0.58	1.49%	0.61	4.46%
Edge_sill	1.62	1.60	-1.23%	1.62	0.11%	1.75	8.45%
Edge_head	1.62	1.60	-1.36%	1.62	0.11%	1.75	8.64%
Edge_jamb	1.63	1.61	-0.89%	1.63	0.21%	1.68	4.08%
<b>TOTAL</b>	<b>3.14</b>	<b>3.14</b>	<b>-0.22%</b>	<b>3.14</b>	<b>-0.18%</b>	<b>3.10</b>	<b>-1.01%</b>

**Table 6.5-42: AL Window – Medium Size, Highly Conducting Spacer (Conduction Model)**

<b>Dbf Clear</b>	<b>Spacer keff =</b>		<b>1.900 W/mK</b>				
<b>Section</b>	<b>T5/W5</b>	<b>2-D</b>	<b>% diff</b>	<b>2-D*</b>	<b>% diff</b>	<b>3-D</b>	<b>% diff</b>
	<b>W/m<sup>2</sup>K</b>	<b>W/m<sup>2</sup>K</b>	<b>2D vs T5/W5</b>	<b>W/m<sup>2</sup>K</b>	<b>2D* vs T5/W5</b>	<b>W/m<sup>2</sup>K</b>	<b>3D vs 2-D</b>
Frame_sill	8.89	8.83	-0.59%	8.98	1.06%	8.62	-2.54%
Frame_head	8.89	8.83	-0.66%	8.98	1.07%	8.62	-2.45%
Frame_jamb	8.89	8.84	-0.58%	8.73	-1.79%	8.56	-3.19%
Center of glass	2.80	2.80	-0.02%	2.80	-0.01%	2.80	0.27%
Edge_sill	3.25	3.24	-0.24%	3.26	0.29%	3.31	2.27%
Edge_head	3.25	3.24	-0.28%	3.26	0.29%	3.31	2.32%
Edge_jamb	3.25	3.24	-0.27%	3.26	0.16%	3.28	1.15%
<b>TOTAL</b>	<b>4.64</b>	<b>4.62</b>	<b>-0.33%</b>	<b>4.62</b>	<b>-0.38%</b>	<b>4.56</b>	<b>-1.26%</b>
<b>Dbf Low-e HC</b>	<b>Spacer keff =</b>		<b>1.900 W/mK</b>				
<b>Section</b>	<b>T5/W5</b>	<b>2-D</b>	<b>% diff</b>	<b>2-D*</b>	<b>% diff</b>	<b>3-D</b>	<b>% diff</b>
	<b>W/m<sup>2</sup>K</b>	<b>W/m<sup>2</sup>K</b>	<b>2D vs T5/W5</b>	<b>W/m<sup>2</sup>K</b>	<b>2D* vs T5/W5</b>	<b>W/m<sup>2</sup>K</b>	<b>3D vs 2-D</b>
Frame_sill	8.83	8.77	-0.67%	8.93	1.08%	8.57	-2.39%
Frame_head	8.83	8.76	-0.76%	8.93	1.07%	8.57	-2.31%
Frame_jamb	8.83	8.77	-0.67%	8.67	-1.83%	8.51	-3.10%
Center of glass	1.73	1.75	1.00%	1.75	1.03%	1.77	0.88%
Edge_sill	2.48	2.48	0.03%	2.50	0.88%	2.59	4.34%
Edge_head	2.48	2.48	0.02%	2.50	0.92%	2.59	4.42%
Edge_jamb	2.48	2.48	0.13%	2.50	0.84%	2.54	2.15%
<b>TOTAL</b>	<b>3.93</b>	<b>3.93</b>	<b>-0.15%</b>	<b>3.93</b>	<b>-0.15%</b>	<b>3.88</b>	<b>-1.15%</b>
<b>Dbf Low-e SC</b>	<b>Spacer keff =</b>		<b>1.900 W/mK</b>				
<b>Section</b>	<b>T5/W5</b>	<b>2-D</b>	<b>% diff</b>	<b>2-D*</b>	<b>% diff</b>	<b>3-D</b>	<b>% diff</b>
	<b>W/m<sup>2</sup>K</b>	<b>W/m<sup>2</sup>K</b>	<b>2D vs T5/W5</b>	<b>W/m<sup>2</sup>K</b>	<b>2D* vs T5/W5</b>	<b>W/m<sup>2</sup>K</b>	<b>3D vs 2-D</b>
Frame_sill	8.82	8.76	-0.72%	8.91	1.06%	8.55	-2.35%
Frame_head	8.82	8.75	-0.79%	8.91	1.06%	8.55	-2.28%
Frame_jamb	8.82	8.76	-0.71%	8.66	-1.85%	8.50	-3.07%
Center of glass	1.47	1.46	-0.29%	1.46	-0.26%	1.48	1.24%
Edge_sill	2.30	2.28	-0.69%	2.30	0.29%	2.40	5.13%
Edge_head	2.30	2.28	-0.75%	2.30	0.29%	2.40	5.23%
Edge_jamb	2.30	2.28	-0.58%	2.30	0.26%	2.34	2.55%
<b>TOTAL</b>	<b>3.76</b>	<b>3.74</b>	<b>-0.58%</b>	<b>3.74</b>	<b>-0.55%</b>	<b>3.70</b>	<b>-1.10%</b>
<b>Hypothetical R10</b>	<b>Spacer keff =</b>		<b>1.900 W/mK</b>				
<b>Section</b>	<b>T5/W5</b>	<b>2-D</b>	<b>% diff</b>	<b>2-D*</b>	<b>% diff</b>	<b>3-D</b>	<b>% diff</b>
	<b>W/m<sup>2</sup>K</b>	<b>W/m<sup>2</sup>K</b>	<b>2D vs T5/W5</b>	<b>W/m<sup>2</sup>K</b>	<b>2D* vs T5/W5</b>	<b>W/m<sup>2</sup>K</b>	<b>3D vs 2-D</b>
Frame_sill	8.75	8.71	-0.43%	8.87	1.42%	8.52	-2.24%
Frame_head	8.75	8.70	-0.53%	8.87	1.41%	8.52	-2.14%
Frame_jamb	8.75	8.67	-0.86%	8.62	-1.51%	8.46	-2.55%
Center of glass	0.58	0.58	1.49%	0.59	1.63%	0.61	4.76%
Edge_sill	1.72	1.68	-2.72%	1.70	-1.15%	1.84	8.63%
Edge_head	1.72	1.68	-2.82%	1.70	-1.15%	1.84	8.80%
Edge_jamb	1.72	1.61	-7.04%	1.70	-1.14%	1.76	8.36%
<b>TOTAL</b>	<b>3.18</b>	<b>3.15</b>	<b>-1.13%</b>	<b>3.17</b>	<b>-0.37%</b>	<b>3.14</b>	<b>-0.25%</b>

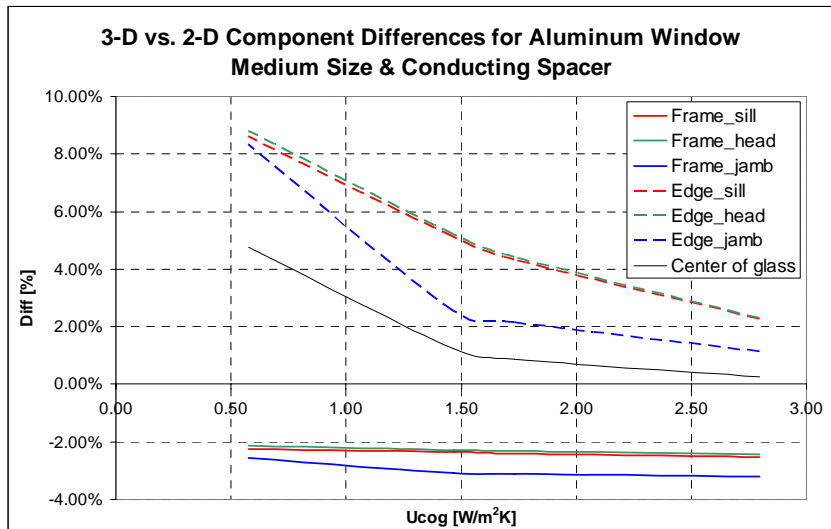
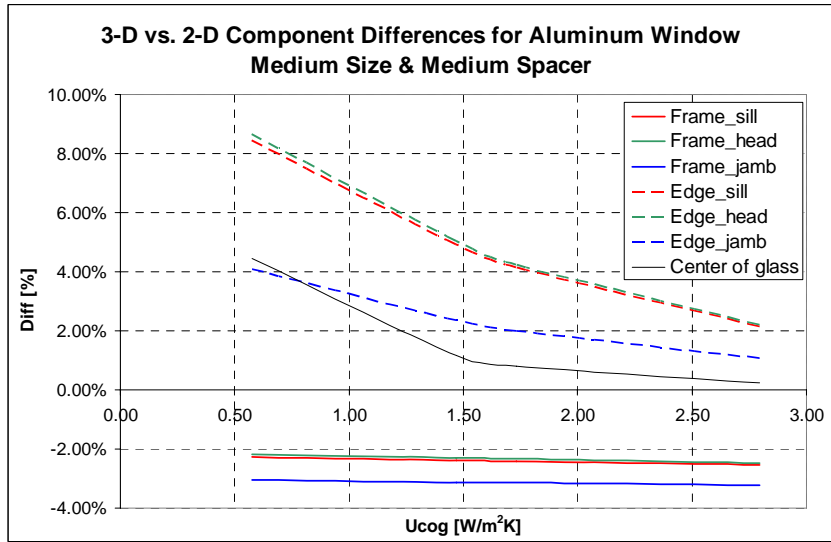
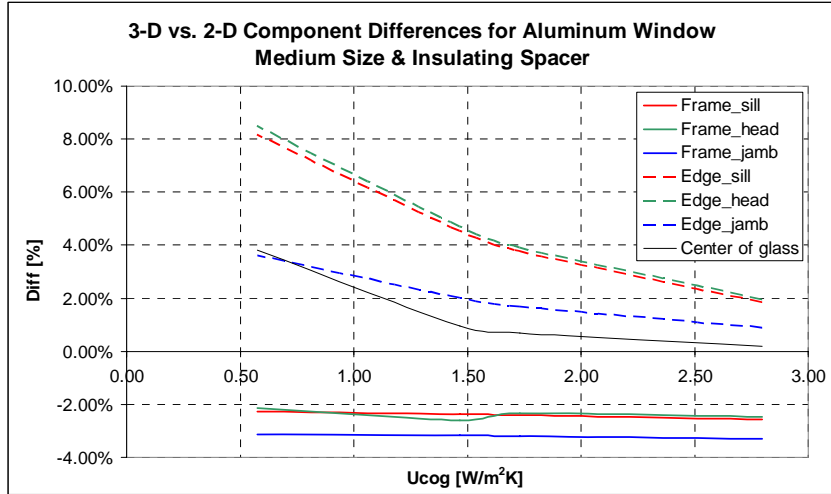

Figure 6.5-14: Component Level Difference Graphs for Medium Size AL Window (Conduction Model)

**Table 6.5-43: AL Window – Small Size, Insulating Spacer (Conduction Model)**

<b>Dbf Clear</b>		<b>Spacer keff = 0.050 W/mK</b>					
<b>Section</b>	<b>T5/W5</b>	<b>2-D</b>	<b>% diff</b>	<b>2-D*</b>	<b>% diff</b>	<b>3-D</b>	<b>% diff</b>
	<b>W/m<sup>2</sup>K</b>	<b>W/m<sup>2</sup>K</b>	<b>2D vs T5/W5</b>	<b>W/m<sup>2</sup>K</b>	<b>2D* vs T5/W5</b>	<b>W/m<sup>2</sup>K</b>	<b>3D vs 2-D</b>
Frame_sill	8.80	8.76	-0.47%	8.90	1.17%	8.55	-2.39%
Frame_head	8.80	8.75	-0.57%	8.90	1.15%	8.55	-2.31%
Frame_jamb	8.80	8.76	-0.43%	8.66	-1.57%	8.66	-1.13%
Center of glass	2.80	2.80	0.06%	2.80	-0.01%	2.80	0.12%
Edge_sill	3.08	3.11	1.04%	3.12	1.22%	3.15	1.43%
Edge_head	3.08	3.11	0.96%	3.12	1.22%	3.15	1.50%
Edge_jamb	3.08	3.12	1.26%	3.12	1.33%	3.15	0.99%
<b>TOTAL</b>	<b>4.72</b>	<b>4.72</b>	<b>0.03%</b>	<b>4.72</b>	<b>0.02%</b>	<b>4.69</b>	<b>-0.71%</b>
<b>Dbf Low-e HC</b>							
		<b>Spacer keff = 0.050 W/mK</b>					
<b>Section</b>	<b>T5/W5</b>	<b>2-D</b>	<b>% diff</b>	<b>2-D*</b>	<b>% diff</b>	<b>3-D</b>	<b>% diff</b>
	<b>W/m<sup>2</sup>K</b>	<b>W/m<sup>2</sup>K</b>	<b>2D vs T5/W5</b>	<b>W/m<sup>2</sup>K</b>	<b>2D* vs T5/W5</b>	<b>W/m<sup>2</sup>K</b>	<b>3D vs 2-D</b>
Frame_sill	8.72	8.67	-0.52%	8.83	1.29%	8.49	-2.16%
Frame_head	8.72	8.66	-0.62%	8.83	1.27%	8.49	-2.08%
Frame_jamb	8.72	8.68	-0.39%	8.59	-1.47%	8.60	-1.01%
Center of glass	1.73	1.75	1.11%	1.75	1.05%	1.76	0.61%
Edge_sill	2.24	2.30	2.56%	2.31	2.84%	2.38	3.26%
Edge_head	2.24	2.30	2.43%	2.31	2.82%	2.38	3.37%
Edge_jamb	2.25	2.32	3.02%	2.32	3.10%	2.36	1.99%
<b>TOTAL</b>	<b>4.02</b>	<b>4.04</b>	<b>0.40%</b>	<b>4.04</b>	<b>0.47%</b>	<b>4.02</b>	<b>-0.49%</b>
<b>Dbf Low-e SC</b>							
		<b>Spacer keff = 0.050 W/mK</b>					
<b>Section</b>	<b>T5/W5</b>	<b>2-D</b>	<b>% diff</b>	<b>2-D*</b>	<b>% diff</b>	<b>3-D</b>	<b>% diff</b>
	<b>W/m<sup>2</sup>K</b>	<b>W/m<sup>2</sup>K</b>	<b>2D vs T5/W5</b>	<b>W/m<sup>2</sup>K</b>	<b>2D* vs T5/W5</b>	<b>W/m<sup>2</sup>K</b>	<b>3D vs 2-D</b>
Frame_sill	8.70	8.65	-0.50%	8.82	1.35%	8.48	-2.09%
Frame_head	8.70	8.64	-0.64%	8.81	1.33%	8.47	-1.97%
Frame_jamb	8.70	8.66	-0.42%	8.58	-1.41%	8.58	-0.89%
Center of glass	1.47	1.47	-0.17%	1.46	-0.22%	1.48	0.91%
Edge_sill	2.04	2.09	2.26%	2.09	2.64%	2.17	4.08%
Edge_head	2.04	2.08	2.09%	2.09	2.59%	2.17	4.20%
Edge_jamb	2.04	2.10	2.75%	2.10	2.88%	2.15	2.47%
<b>TOTAL</b>	<b>3.85</b>	<b>3.85</b>	<b>0.10%</b>	<b>3.86</b>	<b>0.23%</b>	<b>3.84</b>	<b>-0.35%</b>

**Table 6.5-44: AL Window – Small Size, Medium Conducting Spacer (Conduction Model)**

<b>Dbf Clear</b>		<b>Spacer keff = 0.674</b>		<b>W/mK</b>			
<b>Section</b>	<b>T5/W5</b>	<b>2-D</b>	<b>% diff</b>	<b>2-D*</b>	<b>% diff</b>	<b>3-D</b>	<b>% diff</b>
	<b>W/m<sup>2</sup>K</b>	<b>W/m<sup>2</sup>K</b>	<b>2D vs T5/W5</b>	<b>W/m<sup>2</sup>K</b>	<b>2D* vs T5/W5</b>	<b>W/m<sup>2</sup>K</b>	<b>3D vs 2-D</b>
Frame_sill	8.86	8.81	-0.57%	8.95	1.08%	8.60	-2.44%
Frame_head	8.86	8.80	-0.70%	8.95	1.07%	8.60	-2.31%
Frame_jamb	8.86	8.82	-0.49%	8.71	-1.67%	8.71	-1.20%
Center of glass	2.80	2.80	0.09%	2.80	0.03%	2.80	0.18%
Edge_sill	3.19	3.20	0.20%	3.20	0.32%	3.25	1.55%
Edge_head	3.19	3.19	0.14%	3.20	0.30%	3.25	1.59%
Edge_jamb	3.19	3.20	0.29%	3.20	0.26%	3.23	1.02%
<b>TOTAL</b>	<b>4.77</b>	<b>4.76</b>	<b>-0.16%</b>	<b>4.76</b>	<b>-0.20%</b>	<b>4.73</b>	<b>-0.71%</b>
<b>Dbf Low-e HC</b>		<b>Spacer keff = 0.674</b>		<b>W/mK</b>			
<b>Section</b>	<b>T5/W5</b>	<b>2-D</b>	<b>% diff</b>	<b>2-D*</b>	<b>% diff</b>	<b>3-D</b>	<b>% diff</b>
	<b>U-value</b>	<b>U-value</b>	<b>2D vs T5/W5</b>	<b>U-value</b>	<b>2D* vs T5/W5</b>	<b>U-value</b>	<b>3D vs 2-D</b>
Frame_sill	8.79	8.74	-0.66%	8.89	1.13%	8.54	-2.24%
Frame_head	8.79	8.73	-0.77%	8.89	1.12%	8.54	-2.14%
Frame_jamb	8.80	8.75	-0.57%	8.65	-1.64%	8.65	-1.04%
Center of glass	1.73	1.75	1.18%	1.75	1.12%	1.77	0.74%
Edge_sill	2.41	2.42	0.74%	2.43	0.89%	2.51	3.35%
Edge_head	2.41	2.42	0.66%	2.43	0.83%	2.51	3.37%
Edge_jamb	2.41	2.43	0.94%	2.43	0.83%	2.48	1.98%
<b>TOTAL</b>	<b>4.09</b>	<b>4.09</b>	<b>0.01%</b>	<b>4.09</b>	<b>0.04%</b>	<b>4.07</b>	<b>-0.48%</b>
<b>Dbf Low-e SC</b>		<b>Spacer keff = 0.674</b>		<b>W/mK</b>			
<b>Section</b>	<b>T5/W5</b>	<b>2-D</b>	<b>% diff</b>	<b>2-D*</b>	<b>% diff</b>	<b>3-D</b>	<b>% diff</b>
	<b>U-value</b>	<b>U-value</b>	<b>2D vs T5/W5</b>	<b>U-value</b>	<b>2D* vs T5/W5</b>	<b>U-value</b>	<b>3D vs 2-D</b>
Frame_sill	8.78	8.72	-0.67%	8.88	1.13%	8.53	-2.22%
Frame_head	8.78	8.71	-0.79%	8.88	1.12%	8.53	-2.10%
Frame_jamb	8.78	8.73	-0.60%	8.64	-1.64%	8.64	-1.00%
Center of glass	1.47	1.47	-0.06%	1.47	-0.11%	1.48	1.07%
Edge_sill	2.22	2.22	0.12%	2.22	0.20%	2.31	4.05%
Edge_head	2.22	2.22	0.02%	2.22	0.20%	2.31	4.08%
Edge_jamb	2.22	2.22	0.30%	2.22	0.17%	2.28	2.37%
<b>TOTAL</b>	<b>3.92</b>	<b>3.91</b>	<b>-0.34%</b>	<b>3.91</b>	<b>-0.29%</b>	<b>3.89</b>	<b>-0.39%</b>



**Table 6.5-45: AL Window – Small Size, Highly Conducting Spacer (Conduction Model)**

<b>Dbf Clear</b>	<b>Spacer keff = 1.900</b>			<b>W/mK</b>				
<b>Section</b>	<b>T5/W5</b>	<b>2-D</b>	<b>% diff</b>	<b>2-D*</b>	<b>% diff</b>	<b>3-D</b>	<b>% diff</b>	
	<b>U-value</b>	<b>U-value</b>	<b>2D vs T5/W5</b>	<b>U-value</b>	<b>2D* vs T5/W5</b>	<b>U-value</b>	<b>3D vs 2-D</b>	
Frame_sill	8.89	8.83	-0.58%	8.98	1.06%	8.62	-2.47%	
Frame_head	8.89	8.82	-0.70%	8.98	1.07%	8.62	-2.34%	
Frame_jamb	8.89	8.84	-0.48%	8.74	-1.68%	8.74	-1.24%	
Center of glass	2.80	2.80	0.10%	2.80	0.04%	2.80	0.20%	
Edge_sill	3.25	3.24	-0.24%	3.24	-0.16%	3.29	1.61%	
Edge_head	3.25	3.24	-0.29%	3.24	-0.18%	3.29	1.64%	
Edge_jamb	3.25	3.24	-0.27%	3.24	-0.34%	3.28	1.04%	
<b>TOTAL</b>	<b>4.80</b>	<b>4.78</b>	<b>-0.25%</b>	<b>4.78</b>	<b>-0.30%</b>	<b>4.75</b>	<b>-0.72%</b>	
<b>Dbf Low-e HC</b>	<b>Spacer keff = 1.900</b>			<b>W/mK</b>				
<b>Section</b>	<b>T5/W5</b>	<b>2-D</b>	<b>% diff</b>	<b>2-D*</b>	<b>% diff</b>	<b>3-D</b>	<b>% diff</b>	
	<b>U-value</b>	<b>U-value</b>	<b>2D vs T5/W5</b>	<b>U-value</b>	<b>2D* vs T5/W5</b>	<b>U-value</b>	<b>3D vs 2-D</b>	
Frame_sill	8.83	8.77	-0.70%	8.92	1.02%	8.57	-2.35%	
Frame_head	8.83	8.76	-0.82%	8.92	1.02%	8.57	-2.23%	
Frame_jamb	8.83	8.78	-0.54%	8.68	-1.75%	8.68	-1.22%	
Center of glass	1.73	1.75	1.22%	1.75	1.16%	1.77	0.79%	
Edge_sill	2.48	2.48	0.03%	2.48	0.04%	2.57	3.30%	
Edge_head	2.48	2.48	0.00%	2.48	0.03%	2.56	3.33%	
Edge_jamb	2.48	2.48	0.13%	2.48	-0.07%	2.53	1.94%	
<b>TOTAL</b>	<b>4.12</b>	<b>4.12</b>	<b>-0.10%</b>	<b>4.12</b>	<b>-0.15%</b>	<b>4.10</b>	<b>-0.56%</b>	
<b>Dbf Low-e SC</b>	<b>Spacer keff = 1.900</b>			<b>W/mK</b>				
<b>Section</b>	<b>T5/W5</b>	<b>2-D</b>	<b>% diff</b>	<b>2-D*</b>	<b>% diff</b>	<b>3-D</b>	<b>% diff</b>	
	<b>U-value</b>	<b>U-value</b>	<b>2D vs T5/W5</b>	<b>U-value</b>	<b>2D* vs T5/W5</b>	<b>U-value</b>	<b>3D vs 2-D</b>	
Frame_sill	8.82	8.75	-0.72%	8.91	0.99%	8.55	-2.34%	
Frame_head	8.82	8.74	-0.85%	8.91	0.98%	8.55	-2.23%	
Frame_jamb	8.82	8.77	-0.57%	8.66	-1.80%	8.66	-1.22%	
Center of glass	1.47	1.47	-0.01%	1.47	-0.07%	1.48	1.15%	
Edge_sill	2.30	2.28	-0.69%	2.28	-0.79%	2.37	3.90%	
Edge_head	2.30	2.28	-0.77%	2.28	-0.81%	2.37	3.95%	
Edge_jamb	2.30	2.28	-0.57%	2.28	-0.84%	2.34	2.29%	
<b>TOTAL</b>	<b>3.96</b>	<b>3.94</b>	<b>-0.47%</b>	<b>3.93</b>	<b>-0.54%</b>	<b>3.92</b>	<b>-0.51%</b>	

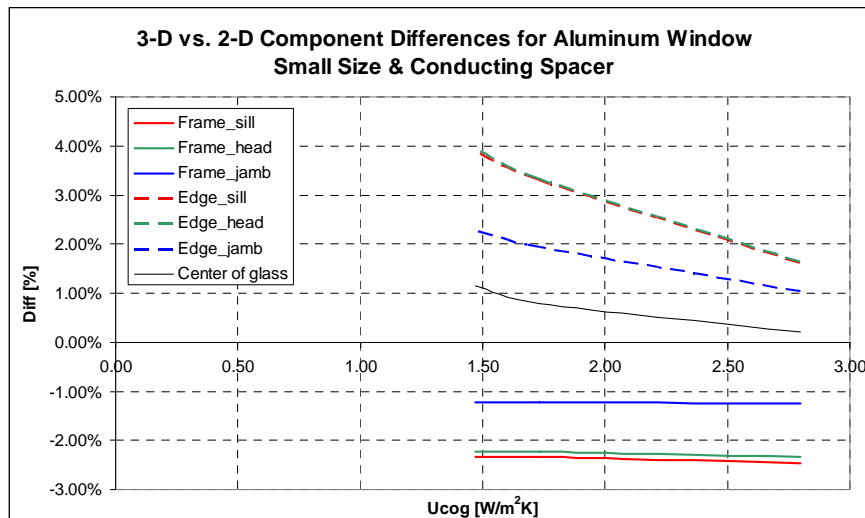
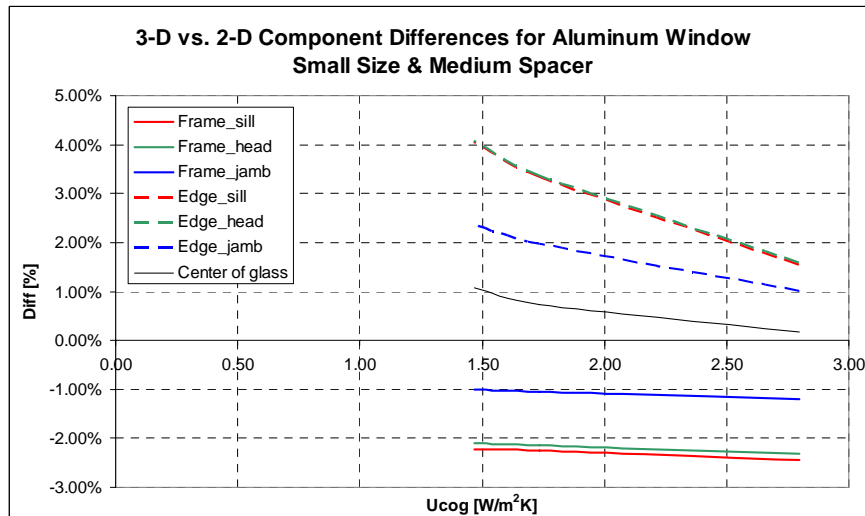
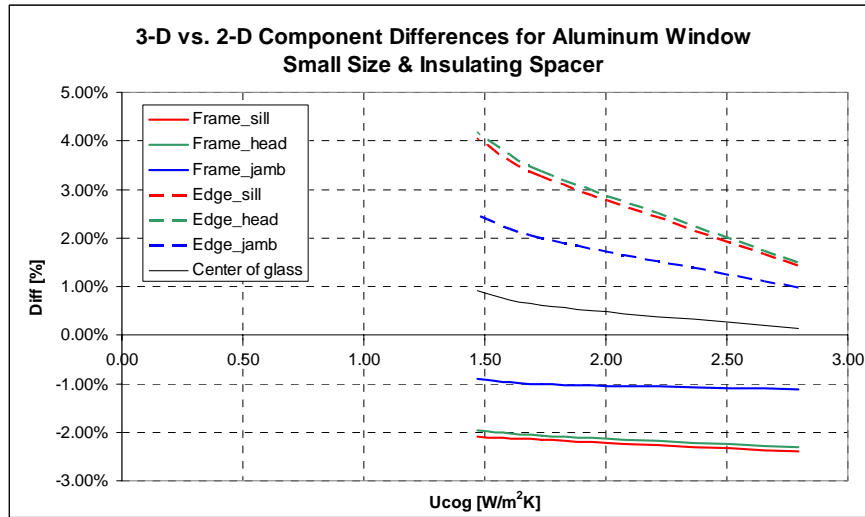

**Figure 6.5-15: Component Level Difference Graphs for Small Size AL Window**

### 6.5.8 Component level results and comparisons for PVC window (conduction models)

**Table 6.5-46: PVC Window – Large Size, Insulating Spacer (Conduction Model)**

DbI Clear		Spacer keff =		0.050		W/mK	
Section	T5/W5	2-D	% diff	2-D*	% diff	3-D	% diff
	W/m <sup>2</sup> K	W/m <sup>2</sup> K	2D vs T5/W5	W/m <sup>2</sup> K	2D* vs T5/W5	W/m <sup>2</sup> K	3D vs 2-D
Frame_sill	2.11	2.03	-3.52%	2.04	-3.01%	2.02	-0.50%
Frame_head	2.11	2.04	-3.49%	2.04	-3.12%	2.02	-0.60%
Frame_jamb	2.33	2.23	-4.18%	2.17	-7.17%	2.23	-0.19%
Center of glass	2.80	2.79	-0.07%	2.79	-0.11%	2.79	-0.02%
Edge_sill	2.82	2.83	0.22%	2.83	0.22%	2.84	0.41%
Edge_head	2.82	2.83	0.25%	2.83	0.23%	2.84	0.39%
Edge_jamb	2.83	2.84	0.14%	2.83	0.11%	2.84	0.08%
<b>TOTAL</b>	<b>2.66</b>	<b>2.64</b>	<b>-0.85%</b>	<b>2.63</b>	<b>-1.32%</b>	<b>2.64</b>	<b>-0.03%</b>
DbI Low-e HC		Spacer keff =		0.050		W/mK	
Section	T5/W5	2-D	% diff	2-D*	% diff	3-D	% diff
	W/m <sup>2</sup> K	W/m <sup>2</sup> K	2D vs T5/W5	W/m <sup>2</sup> K	2D* vs T5/W5	W/m <sup>2</sup> K	3D vs 2-D
Frame_sill	1.93	1.86	-3.57%	1.87	-3.17%	1.87	0.67%
Frame_head	1.93	1.86	-3.52%	1.87	-3.27%	1.87	0.56%
Frame_jamb	2.15	2.06	-4.35%	2.00	-7.49%	2.06	0.27%
Center of glass	1.73	1.75	0.79%	1.75	0.75%	1.75	0.20%
Edge_sill	1.91	1.93	1.06%	1.93	0.92%	1.96	1.63%
Edge_head	1.91	1.93	1.13%	1.93	0.92%	1.96	1.56%
Edge_jamb	1.93	1.94	0.59%	1.94	0.60%	1.95	0.54%
<b>TOTAL</b>	<b>1.88</b>	<b>1.86</b>	<b>-0.64%</b>	<b>1.85</b>	<b>-1.28%</b>	<b>1.87</b>	<b>0.40%</b>
DbI Low-e SC		Spacer keff =		0.050		W/mK	
Section	T5/W5	2-D	% diff	2-D*	% diff	3-D	% diff
	W/m <sup>2</sup> K	W/m <sup>2</sup> K	2D vs T5/W5	W/m <sup>2</sup> K	2D* vs T5/W5	W/m <sup>2</sup> K	3D vs 2-D
Frame_sill	1.88	1.81	-3.83%	1.82	-3.42%	1.83	1.05%
Frame_head	1.88	1.82	-3.77%	1.82	-3.52%	1.83	0.92%
Frame_jamb	2.10	2.01	-4.59%	1.95	-7.79%	2.02	0.39%
Center of glass	1.47	1.46	-0.60%	1.46	-0.64%	1.46	0.34%
Edge_sill	1.69	1.69	0.00%	1.69	-0.15%	1.73	2.25%
Edge_head	1.69	1.69	0.09%	1.69	-0.15%	1.73	2.17%
Edge_jamb	1.72	1.71	-0.45%	1.71	-0.44%	1.72	0.73%
<b>TOTAL</b>	<b>1.68</b>	<b>1.65</b>	<b>-1.73%</b>	<b>1.64</b>	<b>-2.45%</b>	<b>1.66</b>	<b>0.59%</b>
Hypothetical R10		Spacer keff =		0.050		W/mK	
Section	T5/W5	2-D	% diff	2-D*	% diff	3-D	% diff
	W/m <sup>2</sup> K	W/m <sup>2</sup> K	2D vs T5/W5	W/m <sup>2</sup> K	2D* vs T5/W5	W/m <sup>2</sup> K	3D vs 2-D
Frame_sill	1.65	1.68	1.65%	1.69	2.13%	1.72	2.32%
Frame_head	1.65	1.68	1.75%	1.69	2.10%	1.72	2.21%
Frame_jamb	1.83	1.88	2.81%	1.82	-0.36%	1.89	0.74%
Center of glass	0.58	0.58	0.18%	0.58	0.17%	0.59	1.86%
Edge_sill	1.00	0.97	-3.18%	0.97	-3.27%	1.04	6.19%
Edge_head	1.01	0.97	-3.17%	0.97	-3.38%	1.04	6.09%
Edge_jamb	1.04	1.00	-4.74%	1.00	-4.85%	1.02	1.81%
<b>TOTAL</b>	<b>1.01</b>	<b>1.01</b>	<b>0.24%</b>	<b>1.00</b>	<b>-0.89%</b>	<b>1.03</b>	<b>1.73%</b>

**Table 6.5-47: PVC Window – Large Size, Medium Conducting Spacer (Conduction Model)**

<b>DbI Clear</b>	<b>Spacer keff =</b>		<b>0.674 W/mK</b>				
<b>Section</b>	<b>T5/W5</b>	<b>2-D</b>	<b>% diff</b>	<b>2-D*</b>	<b>% diff</b>	<b>3-D</b>	<b>% diff</b>
	<b>W/m<sup>2</sup>K</b>	<b>W/m<sup>2</sup>K</b>	<b>2D vs T5/W5</b>	<b>W/m<sup>2</sup>K</b>	<b>2D* vs T5/W5</b>	<b>W/m<sup>2</sup>K</b>	<b>3D vs 2-D</b>
Frame_sill	2.50	2.41	-3.76%	2.43	-3.22%	2.37	-1.67%
Frame_head	2.50	2.41	-3.75%	2.42	-3.36%	2.37	-1.77%
Frame_jamb	2.71	2.61	-3.74%	2.55	-6.42%	2.60	-0.56%
Center of glass	2.80	2.80	-0.03%	2.79	-0.07%	2.80	0.11%
Edge_sill	3.05	3.06	0.33%	3.06	0.34%	3.09	1.20%
Edge_head	3.05	3.06	0.36%	3.06	0.35%	3.09	1.17%
Edge_jamb	3.04	3.05	0.30%	3.05	0.26%	3.06	0.35%
<b>TOTAL</b>	<b>2.82</b>	<b>2.80</b>	<b>-0.84%</b>	<b>2.78</b>	<b>-1.30%</b>	<b>2.80</b>	<b>-0.01%</b>
<b>DbI Low-e HC</b>	<b>Spacer keff =</b>		<b>0.674 W/mK</b>				
<b>Section</b>	<b>T5/W5</b>	<b>2-D</b>	<b>% diff</b>	<b>2-D*</b>	<b>% diff</b>	<b>3-D</b>	<b>% diff</b>
	<b>W/m<sup>2</sup>K</b>	<b>W/m<sup>2</sup>K</b>	<b>2D vs T5/W5</b>	<b>W/m<sup>2</sup>K</b>	<b>2D* vs T5/W5</b>	<b>W/m<sup>2</sup>K</b>	<b>3D vs 2-D</b>
Frame_sill	2.40	2.32	-3.52%	2.33	-3.05%	2.29	-1.14%
Frame_head	2.40	2.32	-3.52%	2.32	-3.19%	2.29	-1.23%
Frame_jamb	2.61	2.51	-3.79%	2.45	-6.48%	2.50	-0.29%
Center of glass	1.73	1.75	0.89%	1.75	0.86%	1.76	0.55%
Edge_sill	2.23	2.25	0.94%	2.25	0.85%	2.31	2.80%
Edge_head	2.23	2.25	0.98%	2.25	0.85%	2.31	2.76%
Edge_jamb	2.23	2.24	0.69%	2.24	0.71%	2.27	0.96%
<b>TOTAL</b>	<b>2.07</b>	<b>2.06</b>	<b>-0.59%</b>	<b>2.05</b>	<b>-1.19%</b>	<b>2.07</b>	<b>0.44%</b>
<b>DbI Low-e SC</b>	<b>Spacer keff =</b>		<b>0.674 W/mK</b>				
<b>Section</b>	<b>T5/W5</b>	<b>2-D</b>	<b>% diff</b>	<b>2-D*</b>	<b>% diff</b>	<b>3-D</b>	<b>% diff</b>
	<b>W/m<sup>2</sup>K</b>	<b>W/m<sup>2</sup>K</b>	<b>2D vs T5/W5</b>	<b>W/m<sup>2</sup>K</b>	<b>2D* vs T5/W5</b>	<b>W/m<sup>2</sup>K</b>	<b>3D vs 2-D</b>
Frame_sill	2.37	2.29	-3.63%	2.30	-3.19%	2.27	-0.98%
Frame_head	2.37	2.29	-3.62%	2.30	-3.33%	2.27	-1.08%
Frame_jamb	2.58	2.48	-3.92%	2.42	-6.67%	2.48	-0.26%
Center of glass	1.47	1.46	-0.46%	1.46	-0.50%	1.47	0.81%
Edge_sill	2.03	2.03	0.16%	2.03	0.00%	2.11	3.42%
Edge_head	2.03	2.03	0.22%	2.03	0.00%	2.11	3.36%
Edge_jamb	2.03	2.03	-0.15%	2.03	-0.18%	2.05	1.14%
<b>TOTAL</b>	<b>1.89</b>	<b>1.86</b>	<b>-1.52%</b>	<b>1.85</b>	<b>-2.20%</b>	<b>1.87</b>	<b>0.61%</b>
<b>Hypothetical R10</b>	<b>Spacer keff =</b>		<b>0.674 W/mK</b>				
<b>Section</b>	<b>T5/W5</b>	<b>2-D</b>	<b>% diff</b>	<b>2-D*</b>	<b>% diff</b>	<b>3-D</b>	<b>% diff</b>
	<b>W/m<sup>2</sup>K</b>	<b>W/m<sup>2</sup>K</b>	<b>2D vs T5/W5</b>	<b>W/m<sup>2</sup>K</b>	<b>2D* vs T5/W5</b>	<b>W/m<sup>2</sup>K</b>	<b>3D vs 2-D</b>
Frame_sill	2.17	2.22	1.87%	2.23	2.43%	2.21	-0.35%
Frame_head	2.17	2.21	2.03%	2.23	2.47%	2.21	-0.43%
Frame_jamb	2.31	2.41	4.04%	2.35	1.50%	2.41	-0.03%
Center of glass	0.58	0.58	0.71%	0.58	0.74%	0.60	3.52%
Edge_sill	1.42	1.39	-2.73%	1.39	-2.71%	1.49	7.02%
Edge_head	1.43	1.39	-2.85%	1.39	-2.85%	1.49	7.00%
Edge_jamb	1.44	1.38	-3.99%	1.39	-3.96%	1.42	2.37%
<b>TOTAL</b>	<b>1.24</b>	<b>1.25</b>	<b>0.94%</b>	<b>1.24</b>	<b>0.05%</b>	<b>1.27</b>	<b>1.70%</b>

**Table 6.5-48: PVC Window – Large Size, Highly Conducting Spacer (Conduction Model)**

<b>Dbl Clear</b>	<b>Spacer keff = 1.900</b>		<b>W/mK</b>				
<b>Section</b>	<b>T5/W5</b>	<b>2-D</b>	<b>% diff</b>	<b>2-D*</b>	<b>% diff</b>	<b>3-D</b>	<b>% diff</b>
	<b>W/m<sup>2</sup>K</b>	<b>W/m<sup>2</sup>K</b>	<b>2D vs T5/W5</b>	<b>W/m<sup>2</sup>K</b>	<b>2D* vs T5/W5</b>	<b>W/m<sup>2</sup>K</b>	<b>3D vs 2-D</b>
Frame_sill	2.66	2.56	-3.90%	2.58	-3.30%	2.51	-2.08%
Frame_head	2.66	2.56	-3.88%	2.57	-3.42%	2.51	-2.17%
Frame_jamb	2.88	2.77	-4.12%	2.70	-6.66%	2.75	-0.67%
Center of glass	2.80	2.80	-0.02%	2.79	-0.06%	2.80	0.16%
Edge_sill	3.15	3.15	-0.02%	3.15	0.03%	3.20	1.50%
Edge_head	3.15	3.15	0.03%	3.15	0.07%	3.20	1.49%
Edge_jamb	3.14	3.14	-0.02%	3.14	-0.02%	3.16	0.48%
<b>TOTAL</b>	<b>2.89</b>	<b>2.86</b>	<b>-1.00%</b>	<b>2.85</b>	<b>-1.44%</b>	<b>2.86</b>	<b>0.01%</b>
<b>Dbl Low-e HC</b>	<b>Spacer keff = 1.900</b>		<b>W/mK</b>				
<b>Section</b>	<b>T5/W5</b>	<b>2-D</b>	<b>% diff</b>	<b>2-D*</b>	<b>% diff</b>	<b>3-D</b>	<b>% diff</b>
	<b>W/m<sup>2</sup>K</b>	<b>W/m<sup>2</sup>K</b>	<b>2D vs T5/W5</b>	<b>W/m<sup>2</sup>K</b>	<b>2D* vs T5/W5</b>	<b>W/m<sup>2</sup>K</b>	<b>3D vs 2-D</b>
Frame_sill	2.58	2.49	-3.82%	2.50	-3.31%	2.44	-1.72%
Frame_head	2.58	2.48	-3.85%	2.49	-3.47%	2.44	-1.79%
Frame_jamb	2.80	2.69	-4.27%	2.62	-6.82%	2.67	-0.48%
Center of glass	1.73	1.75	0.93%	1.75	0.89%	1.76	0.68%
Edge_sill	2.36	2.37	0.23%	2.37	0.15%	2.45	3.13%
Edge_head	2.36	2.37	0.30%	2.37	0.19%	2.45	3.10%
Edge_jamb	2.36	2.36	0.04%	2.36	0.08%	2.39	1.09%
<b>TOTAL</b>	<b>2.16</b>	<b>2.14</b>	<b>-0.98%</b>	<b>2.12</b>	<b>-1.55%</b>	<b>2.14</b>	<b>0.45%</b>
<b>Dbl Low-e SC</b>	<b>Spacer keff = 1.900</b>		<b>W/mK</b>				
<b>Section</b>	<b>T5/W5</b>	<b>2-D</b>	<b>% diff</b>	<b>2-D*</b>	<b>% diff</b>	<b>3-D</b>	<b>% diff</b>
	<b>W/m<sup>2</sup>K</b>	<b>W/m<sup>2</sup>K</b>	<b>2D vs T5/W5</b>	<b>W/m<sup>2</sup>K</b>	<b>2D* vs T5/W5</b>	<b>W/m<sup>2</sup>K</b>	<b>3D vs 2-D</b>
Frame_sill	2.56	2.46	-3.94%	2.48	-3.35%	2.43	-1.53%
Frame_head	2.56	2.46	-3.96%	2.47	-3.52%	2.43	-1.61%
Frame_jamb	2.78	2.66	-4.39%	2.60	-6.90%	2.65	-0.38%
Center of glass	1.47	1.46	-0.40%	1.46	-0.43%	1.48	1.01%
Edge_sill	2.18	2.16	-0.64%	2.16	-0.63%	2.25	3.93%
Edge_head	2.17	2.16	-0.55%	2.16	-0.59%	2.25	3.88%
Edge_jamb	2.17	2.15	-0.84%	2.16	-0.71%	2.18	1.42%
<b>TOTAL</b>	<b>1.98</b>	<b>1.94</b>	<b>-1.88%</b>	<b>1.93</b>	<b>-2.46%</b>	<b>1.95</b>	<b>0.69%</b>
<b>Hypothetical R10</b>	<b>Spacer keff = 1.900</b>		<b>W/mK</b>				
<b>Section</b>	<b>T5/W5</b>	<b>2-D</b>	<b>% diff</b>	<b>2-D*</b>	<b>% diff</b>	<b>3-D</b>	<b>% diff</b>
	<b>W/m<sup>2</sup>K</b>	<b>W/m<sup>2</sup>K</b>	<b>2D vs T5/W5</b>	<b>W/m<sup>2</sup>K</b>	<b>2D* vs T5/W5</b>	<b>W/m<sup>2</sup>K</b>	<b>3D vs 2-D</b>
Frame_sill	2.38	2.40	1.02%	2.42	1.70%	2.38	-1.05%
Frame_head	2.37	2.40	1.23%	2.42	1.79%	2.38	-1.11%
Frame_jamb	2.51	2.61	3.66%	2.54	1.32%	2.60	-0.24%
Center of glass	0.58	0.58	0.91%	0.58	0.94%	0.61	4.14%
Edge_sill	1.60	1.54	-3.98%	1.54	-3.79%	1.66	7.32%
Edge_head	1.60	1.54	-4.11%	1.54	-3.92%	1.66	7.32%
Edge_jamb	1.61	1.53	-5.13%	1.53	-4.96%	1.57	2.56%
<b>TOTAL</b>	<b>1.34</b>	<b>1.34</b>	<b>0.40%</b>	<b>1.33</b>	<b>-0.36%</b>	<b>1.36</b>	<b>1.72%</b>

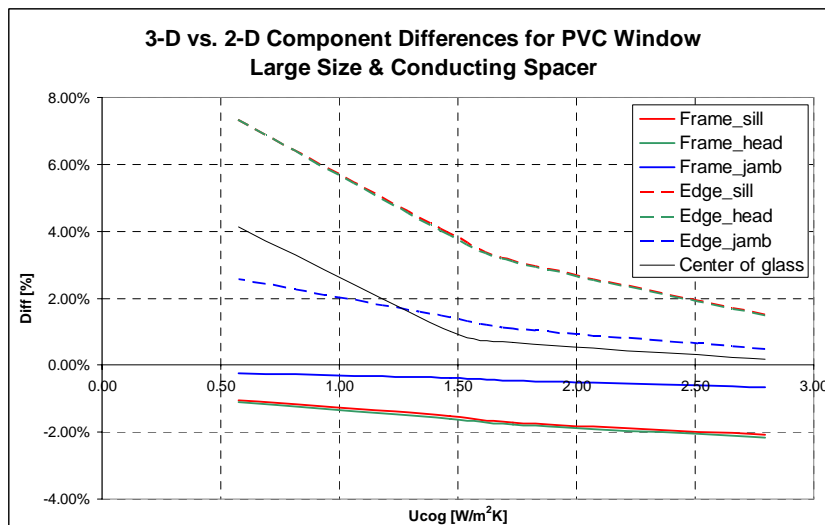
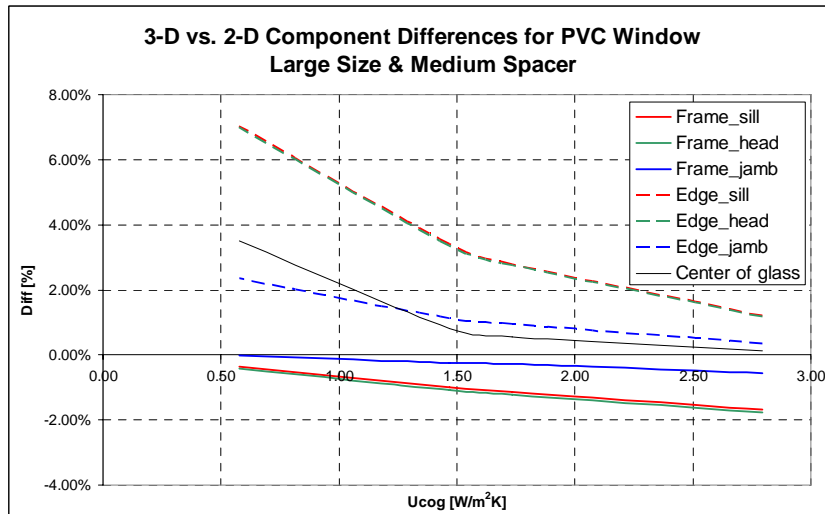
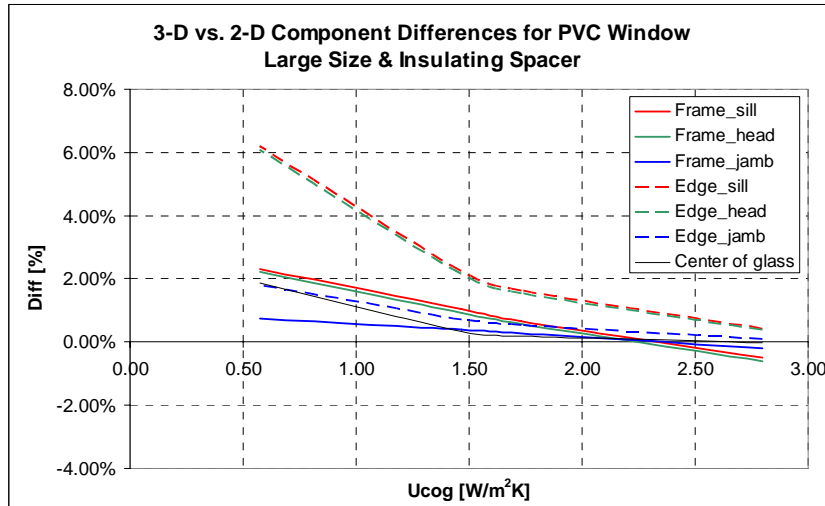

**Figure 6.5-16: Component Level Difference Graphs for Large Size PVC Window (Conduction Model)**

**Table 6.5-49: PVC Window – Medium Size, Insulating Spacer (Conduction Model)**

<b>Dbi Clear</b>		<b>Spacer keff = 0.050</b>		<b>W/mK</b>			
<b>Section</b>	<b>T5/W5</b>	<b>2-D</b>	<b>% diff</b>	<b>2-D*</b>	<b>% diff</b>	<b>3-D</b>	<b>% diff</b>
	<b>W/m<sup>2</sup>K</b>	<b>W/m<sup>2</sup>K</b>	<b>2D vs T5/W5</b>	<b>W/m<sup>2</sup>K</b>	<b>2D* vs T5/W5</b>	<b>W/m<sup>2</sup>K</b>	<b>3D vs 2-D</b>
Frame_sill	2.11	2.04	-3.03%	2.04	-2.99%	2.02	-0.96%
Frame_head	2.11	2.04	-3.01%	2.04	-3.00%	2.02	-0.98%
Frame_jamb	2.33	2.24	-3.80%	2.17	-7.19%	2.23	-0.70%
Center of glass	2.80	2.79	-0.11%	2.79	-0.11%	2.79	0.03%
Edge_sill	2.82	2.83	0.34%	2.83	0.43%	2.85	0.56%
Edge_head	2.82	2.83	0.37%	2.83	0.43%	2.85	0.53%
Edge_jamb	2.83	2.84	0.23%	2.84	0.37%	2.85	0.31%
<b>TOTAL</b>	<b>2.65</b>	<b>2.63</b>	<b>-0.81%</b>	<b>2.62</b>	<b>-1.29%</b>	<b>2.63</b>	<b>-0.09%</b>
<b>Dbi Low-e HC</b>							
<b>Spacer keff = 0.050</b>		<b>W/mK</b>					
<b>Section</b>	<b>T5/W5</b>	<b>2-D</b>	<b>% diff</b>	<b>2-D*</b>	<b>% diff</b>	<b>3-D</b>	<b>% diff</b>
	<b>W/m<sup>2</sup>K</b>	<b>W/m<sup>2</sup>K</b>	<b>2D vs T5/W5</b>	<b>W/m<sup>2</sup>K</b>	<b>2D* vs T5/W5</b>	<b>W/m<sup>2</sup>K</b>	<b>3D vs 2-D</b>
Frame_sill	1.93	1.87	-3.14%	1.87	-3.20%	1.87	0.23%
Frame_head	1.93	1.87	-3.09%	1.87	-3.21%	1.87	0.20%
Frame_jamb	2.15	2.06	-3.89%	1.99	-7.54%	2.06	-0.24%
Center of glass	1.73	1.75	0.76%	1.75	0.76%	1.75	0.24%
Edge_sill	1.91	1.93	1.08%	1.93	1.04%	1.97	1.80%
Edge_head	1.91	1.93	1.12%	1.93	1.03%	1.97	1.76%
Edge_jamb	1.93	1.95	0.77%	1.95	0.85%	1.96	0.76%
<b>TOTAL</b>	<b>1.88</b>	<b>1.87</b>	<b>-0.54%</b>	<b>1.86</b>	<b>-1.27%</b>	<b>1.88</b>	<b>0.33%</b>
<b>Dbi Low-e SC</b>							
<b>Spacer keff = 0.050</b>		<b>W/mK</b>					
<b>Section</b>	<b>T5/W5</b>	<b>2-D</b>	<b>% diff</b>	<b>2-D*</b>	<b>% diff</b>	<b>3-D</b>	<b>% diff</b>
	<b>W/m<sup>2</sup>K</b>	<b>W/m<sup>2</sup>K</b>	<b>2D vs T5/W5</b>	<b>W/m<sup>2</sup>K</b>	<b>2D* vs T5/W5</b>	<b>W/m<sup>2</sup>K</b>	<b>3D vs 2-D</b>
Frame_sill	1.88	1.82	-3.39%	1.82	-3.47%	1.83	0.58%
Frame_head	1.88	1.82	-3.34%	1.82	-3.48%	1.83	0.55%
Frame_jamb	2.10	2.02	-4.12%	1.95	-7.84%	2.02	-0.09%
Center of glass	1.47	1.46	-0.63%	1.46	-0.62%	1.46	0.38%
Edge_sill	1.69	1.69	0.04%	1.69	-0.06%	1.74	2.40%
Edge_head	1.69	1.69	0.08%	1.69	-0.07%	1.74	2.36%
Edge_jamb	1.72	1.71	-0.25%	1.71	-0.19%	1.73	0.98%
<b>TOTAL</b>	<b>1.69</b>	<b>1.66</b>	<b>-1.59%</b>	<b>1.65</b>	<b>-2.42%</b>	<b>1.67</b>	<b>0.53%</b>
<b>Hypothetical R10</b>							
<b>Spacer keff = 0.050</b>		<b>W/mK</b>					
<b>Section</b>	<b>T5/W5</b>	<b>2-D</b>	<b>% diff</b>	<b>2-D*</b>	<b>% diff</b>	<b>3-D</b>	<b>% diff</b>
	<b>W/m<sup>2</sup>K</b>	<b>W/m<sup>2</sup>K</b>	<b>2D vs T5/W5</b>	<b>W/m<sup>2</sup>K</b>	<b>2D* vs T5/W5</b>	<b>W/m<sup>2</sup>K</b>	<b>3D vs 2-D</b>
Frame_sill	1.65	1.69	2.21%	1.69	2.07%	1.72	1.75%
Frame_head	1.65	1.69	2.32%	1.69	2.12%	1.72	1.71%
Frame_jamb	1.83	1.89	3.27%	1.82	-0.38%	1.90	0.39%
Center of glass	0.58	0.58	0.31%	0.58	0.34%	0.59	1.87%
Edge_sill	1.00	0.98	-2.80%	0.97	-3.25%	1.04	6.04%
Edge_head	1.01	0.98	-2.79%	0.97	-3.36%	1.04	5.98%
Edge_jamb	1.04	1.00	-4.37%	1.00	-4.45%	1.02	2.36%
<b>TOTAL</b>	<b>1.03</b>	<b>1.04</b>	<b>0.66%</b>	<b>1.02</b>	<b>-0.69%</b>	<b>1.05</b>	<b>1.70%</b>

**Table 6.5-50: PVC Window – Medium Size, Medium Conducting Spacer  
(Conduction Model)**

<b>Dbf Clear</b>		<b>Spacer keff = 0.674 W/mK</b>					
<b>Section</b>	<b>T5/W5</b>	<b>2-D</b>	<b>% diff</b>	<b>2-D*</b>	<b>% diff</b>	<b>3-D</b>	<b>% diff</b>
	<b>W/m<sup>2</sup>K</b>	<b>W/m<sup>2</sup>K</b>	<b>2D vs T5/W5</b>	<b>W/m<sup>2</sup>K</b>	<b>2D* vs T5/W5</b>	<b>W/m<sup>2</sup>K</b>	<b>3D vs 2-D</b>
Frame_sill	2.50	2.42	-3.43%	2.44	-2.57%	2.39	-1.41%
Frame_head	2.50	2.42	-3.43%	2.44	-2.57%	2.39	-1.40%
Frame_jamb	2.71	2.62	-3.52%	2.56	-5.74%	2.61	-0.41%
Center of glass	2.80	2.79	-0.06%	2.79	-0.05%	2.80	0.16%
Edge_sill	3.05	3.06	0.41%	3.07	0.80%	3.11	1.67%
Edge_head	3.05	3.06	0.43%	3.07	0.80%	3.11	1.65%
Edge_jamb	3.04	3.05	0.33%	3.07	0.81%	3.08	1.00%
<b>TOTAL</b>	<b>2.82</b>	<b>2.79</b>	<b>-0.01</b>	<b>2.79</b>	<b>-1.01%</b>	<b>2.80</b>	<b>0.20%</b>
<b>Dbf Low-e HC</b>		<b>Spacer keff = 0.674 W/mK</b>					
<b>Section</b>	<b>T5/W5</b>	<b>2-D</b>	<b>% diff</b>	<b>2-D*</b>	<b>% diff</b>	<b>3-D</b>	<b>% diff</b>
	<b>W/m<sup>2</sup>K</b>	<b>W/m<sup>2</sup>K</b>	<b>2D vs T5/W5</b>	<b>W/m<sup>2</sup>K</b>	<b>2D* vs T5/W5</b>	<b>W/m<sup>2</sup>K</b>	<b>3D vs 2-D</b>
Frame_sill	2.40	2.32	-3.32%	2.34	-2.33%	2.31	-0.68%
Frame_head	2.40	2.32	-3.32%	2.36	-1.47%	2.31	-0.67%
Frame_jamb	2.61	2.52	-3.56%	2.47	-5.70%	2.52	0.00%
Center of glass	1.73	1.75	0.90%	1.75	0.91%	1.76	0.61%
Edge_sill	2.23	2.25	0.87%	2.26	1.50%	2.33	3.63%
Edge_head	2.23	2.25	0.90%	2.26	1.50%	2.33	3.61%
Edge_jamb	2.23	2.24	0.73%	2.26	1.55%	2.29	2.03%
<b>TOTAL</b>	<b>2.09</b>	<b>2.07</b>	<b>-0.01</b>	<b>2.07</b>	<b>-0.68%</b>	<b>2.09</b>	<b>0.84%</b>
<b>Dbf Low-e SC</b>		<b>Spacer keff = 0.674 W/mK</b>					
<b>Section</b>	<b>T5/W5</b>	<b>2-D</b>	<b>% diff</b>	<b>2-D*</b>	<b>% diff</b>	<b>3-D</b>	<b>% diff</b>
	<b>W/m<sup>2</sup>K</b>	<b>W/m<sup>2</sup>K</b>	<b>2D vs T5/W5</b>	<b>W/m<sup>2</sup>K</b>	<b>2D* vs T5/W5</b>	<b>W/m<sup>2</sup>K</b>	<b>3D vs 2-D</b>
Frame_sill	2.37	2.30	-3.42%	2.32	-2.39%	2.28	-0.48%
Frame_head	2.37	2.30	-3.41%	2.32	-2.39%	2.28	-0.48%
Frame_jamb	2.58	2.49	-3.67%	2.44	-5.79%	2.49	0.11%
Center of glass	1.47	1.46	-0.43%	1.46	-0.41%	1.47	0.88%
Edge_sill	2.03	2.03	0.09%	2.05	0.83%	2.13	4.43%
Edge_head	2.03	2.03	0.09%	2.05	0.82%	2.13	4.44%
Edge_jamb	2.03	2.03	-0.09%	2.05	0.88%	2.08	2.45%
<b>TOTAL</b>	<b>1.91</b>	<b>1.88</b>	<b>-0.01</b>	<b>1.88</b>	<b>-1.62%</b>	<b>1.90</b>	<b>1.11%</b>
<b>Hypothetical R10</b>		<b>Spacer keff = 0.674 W/mK</b>					
<b>Section</b>	<b>T5/W5</b>	<b>2-D</b>	<b>% diff</b>	<b>2-D*</b>	<b>% diff</b>	<b>3-D</b>	<b>% diff</b>
	<b>W/m<sup>2</sup>K</b>	<b>W/m<sup>2</sup>K</b>	<b>2D vs T5/W5</b>	<b>W/m<sup>2</sup>K</b>	<b>2D* vs T5/W5</b>	<b>W/m<sup>2</sup>K</b>	<b>3D vs 2-D</b>
Frame_sill	2.17	2.22	2.14%	2.25	3.25%	2.23	0.16%
Frame_head	2.17	2.22	2.33%	2.25	3.43%	2.23	0.17%
Frame_jamb	2.31	2.41	4.26%	2.37	2.39%	2.43	0.47%
Center of glass	0.58	0.58	1.00%	0.58	1.11%	0.60	3.58%
Edge_sill	1.42	1.39	-2.64%	1.40	-1.38%	1.51	8.32%
Edge_head	1.43	1.39	-2.74%	1.40	-1.52%	1.51	8.31%
Edge_jamb	1.44	1.39	-3.91%	1.41	-2.20%	1.45	4.54%
<b>TOTAL</b>	<b>1.27</b>	<b>1.29</b>	<b>1.18%</b>	<b>1.29</b>	<b>1.11%</b>	<b>1.32</b>	<b>2.52%</b>



**Table 6.5-51: PVC Window – Medium Size, Highly Conducting Spacer (Conduction Model)**

<b>Dbf Clear</b>	<b>Spacer keff = 1.900</b>			<b>W/mK</b>			
<b>Section</b>	<b>T5/W5</b>	<b>2-D</b>	<b>% diff</b>	<b>2-D*</b>	<b>% diff</b>	<b>3-D</b>	<b>% diff</b>
	<b>W/m<sup>2</sup>K</b>	<b>W/m<sup>2</sup>K</b>	<b>2D vs T5/W5</b>	<b>W/m<sup>2</sup>K</b>	<b>2D* vs T5/W5</b>	<b>W/m<sup>2</sup>K</b>	<b>3D vs 2-D</b>
Frame_sill	2.66	2.57	-3.62%	2.60	-2.41%	2.53	-1.51%
Frame_head	2.66	2.57	-3.60%	2.60	-2.38%	2.53	-1.48%
Frame_jamb	2.88	2.77	-3.92%	2.73	-5.65%	2.76	-0.24%
Center of glass	2.80	2.79	-0.04%	2.80	-0.03%	2.80	0.22%
Edge_sill	3.15	3.15	0.04%	3.17	0.51%	3.22	2.02%
Edge_head	3.15	3.15	0.09%	3.17	0.54%	3.22	2.00%
Edge_jamb	3.14	3.14	0.00%	3.16	0.59%	3.18	1.21%
<b>TOTAL</b>	<b>2.89</b>	<b>2.86</b>	<b>-0.01</b>	<b>2.86</b>	<b>-1.07%</b>	<b>2.87</b>	<b>0.31%</b>
<b>Dbf Low-e HC</b>	<b>Spacer keff = 1.900</b>			<b>W/mK</b>			
<b>Section</b>	<b>T5/W5</b>	<b>2-D</b>	<b>% diff</b>	<b>2-D*</b>	<b>% diff</b>	<b>3-D</b>	<b>% diff</b>
	<b>W/m<sup>2</sup>K</b>	<b>W/m<sup>2</sup>K</b>	<b>2D vs T5/W5</b>	<b>W/m<sup>2</sup>K</b>	<b>2D* vs T5/W5</b>	<b>W/m<sup>2</sup>K</b>	<b>3D vs 2-D</b>
Frame_sill	2.58	2.49	-3.68%	2.52	-2.25%	2.47	-0.86%
Frame_head	2.58	2.49	-3.70%	2.52	-2.25%	2.47	-0.84%
Frame_jamb	2.80	2.69	-4.07%	2.65	-5.62%	2.70	0.17%
Center of glass	1.73	1.75	0.95%	1.75	0.97%	1.76	0.75%
Edge_sill	2.36	2.37	0.14%	2.39	0.95%	2.47	4.13%
Edge_head	2.36	2.37	0.19%	2.39	0.99%	2.47	4.12%
Edge_jamb	2.36	2.36	0.07%	2.39	1.09%	2.42	2.36%
<b>TOTAL</b>	<b>2.17</b>	<b>2.15</b>	<b>-0.01</b>	<b>2.15</b>	<b>-0.89%</b>	<b>2.18</b>	<b>1.02%</b>
<b>Dbf Low-e SC</b>	<b>Spacer keff = 1.900</b>			<b>W/mK</b>			
<b>Section</b>	<b>T5/W5</b>	<b>2-D</b>	<b>% diff</b>	<b>2-D*</b>	<b>% diff</b>	<b>3-D</b>	<b>% diff</b>
	<b>W/m<sup>2</sup>K</b>	<b>W/m<sup>2</sup>K</b>	<b>2D vs T5/W5</b>	<b>W/m<sup>2</sup>K</b>	<b>2D* vs T5/W5</b>	<b>W/m<sup>2</sup>K</b>	<b>3D vs 2-D</b>
Frame_sill	2.56	2.47	-3.79%	2.50	-2.30%	2.45	-0.69%
Frame_head	2.56	2.47	-3.81%	2.50	-2.30%	2.45	-0.66%
Frame_jamb	2.78	2.67	-4.20%	2.63	-5.69%	2.68	0.28%
Center of glass	1.47	1.46	-0.36%	1.46	-0.33%	1.48	1.07%
Edge_sill	2.18	2.16	-0.73%	2.18	0.23%	2.27	4.97%
Edge_head	2.17	2.16	-0.67%	2.18	0.27%	2.27	4.96%
Edge_jamb	2.17	2.15	-0.80%	2.18	0.41%	2.22	2.83%
<b>TOTAL</b>	<b>2.00</b>	<b>1.96</b>	<b>-0.02</b>	<b>1.96</b>	<b>-1.72%</b>	<b>1.99</b>	<b>1.32%</b>
<b>Hypothetical R10</b>	<b>Spacer keff = 1.900</b>			<b>W/mK</b>			
<b>Section</b>	<b>T5/W5</b>	<b>2-D</b>	<b>% diff</b>	<b>2-D*</b>	<b>% diff</b>	<b>3-D</b>	<b>% diff</b>
	<b>W/m<sup>2</sup>K</b>	<b>W/m<sup>2</sup>K</b>	<b>2D vs T5/W5</b>	<b>W/m<sup>2</sup>K</b>	<b>2D* vs T5/W5</b>	<b>W/m<sup>2</sup>K</b>	<b>3D vs 2-D</b>
Frame_sill	2.38	2.41	1.25%	2.45	2.85%	2.41	-0.14%
Frame_head	2.37	2.41	1.47%	2.45	3.10%	2.41	-0.09%
Frame_jamb	2.51	2.61	3.84%	2.58	2.62%	2.63	0.63%
Center of glass	0.58	0.58	1.25%	0.58	1.39%	0.61	4.22%
Edge_sill	1.60	1.54	-3.93%	1.56	-2.26%	1.69	8.79%
Edge_head	1.60	1.54	-4.06%	1.56	-2.37%	1.69	8.84%
Edge_jamb	1.61	1.53	-5.10%	1.56	-2.97%	1.61	4.98%
<b>TOTAL</b>	<b>1.37</b>	<b>1.38</b>	<b>0.57%</b>	<b>1.39</b>	<b>0.95%</b>	<b>1.42</b>	<b>2.80%</b>

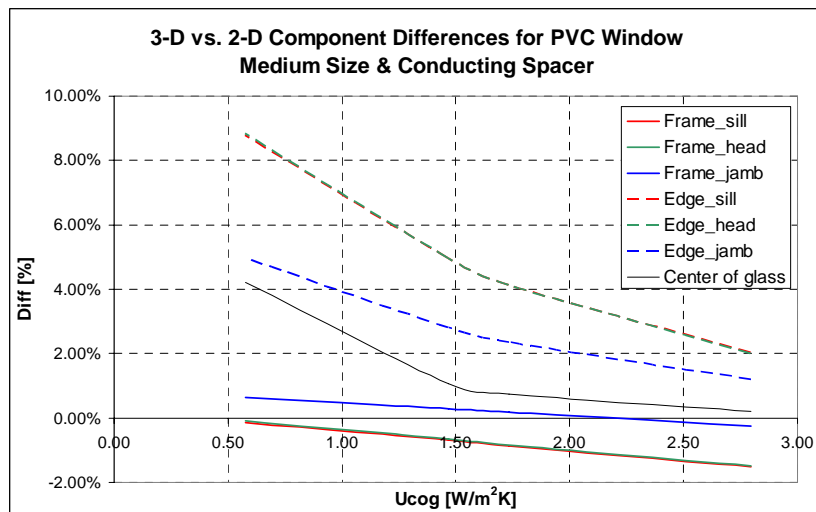
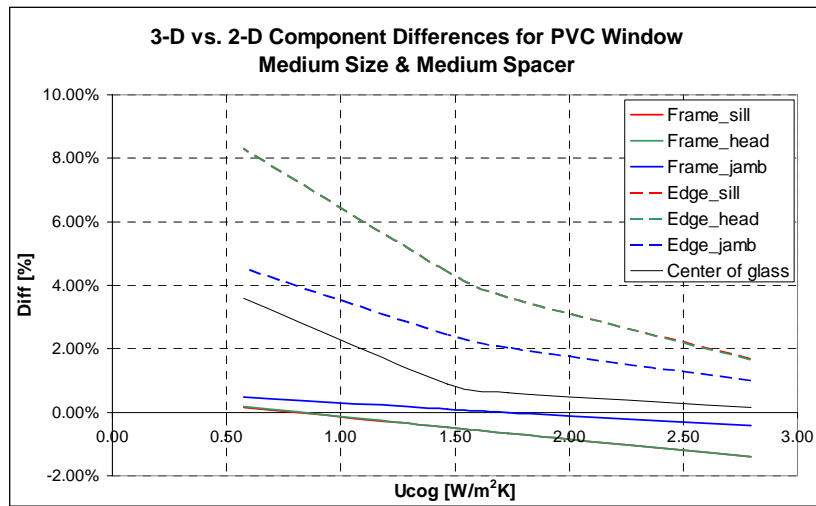
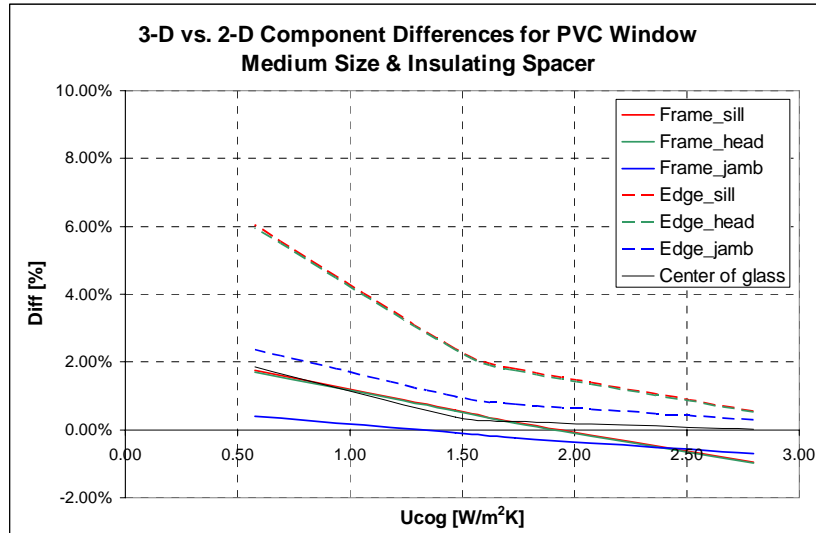

**Figure 6.5-17: Component Level Difference Graphs for Medium Size PVC Window (Conduction Model)**

**Table 6.5-52: PVC Window – Small Size, Insulating Spacer (Conduction Model)**

<b>Dbi Clear</b>		<b>Spacer keff = 0.050</b>		<b>W/mK</b>			
<b>Section</b>	<b>T5/W5</b>	<b>2-D</b>	<b>% diff</b>	<b>2-D*</b>	<b>% diff</b>	<b>3-D</b>	<b>% diff</b>
	<b>W/m<sup>2</sup>K</b>	<b>W/m<sup>2</sup>K</b>	<b>2D vs T5/W5</b>	<b>W/m<sup>2</sup>K</b>	<b>2D* vs T5/W5</b>	<b>W/m<sup>2</sup>K</b>	<b>3D vs 2-D</b>
Frame_sill	2.11	2.03	-3.49%	2.05	-2.81%	2.03	-0.35%
Frame_head	2.11	2.03	-3.49%	2.05	-2.89%	2.03	-0.40%
Frame_jamb	2.33	2.23	-4.17%	2.17	-7.01%	2.22	-0.43%
Center of glass	2.80	2.80	-0.03%	2.79	-0.11%	2.79	-0.06%
Edge_sill	2.82	2.83	0.24%	2.82	0.10%	2.83	0.07%
Edge_head	2.82	2.83	0.27%	2.82	0.11%	2.83	0.05%
Edge_jamb	2.83	2.84	0.15%	2.83	0.02%	2.84	0.13%
<b>TOTAL</b>	<b>2.63</b>	<b>2.61</b>	<b>-0.01</b>	<b>2.60</b>	<b>-1.38%</b>	<b>2.61</b>	<b>-0.14%</b>
<b>Dbi Low-e HC</b>							
<b>Spacer keff = 0.050</b>		<b>W/mK</b>					
<b>Section</b>	<b>T5/W5</b>	<b>2-D</b>	<b>% diff</b>	<b>2-D*</b>	<b>% diff</b>	<b>3-D</b>	<b>% diff</b>
	<b>W/m<sup>2</sup>K</b>	<b>W/m<sup>2</sup>K</b>	<b>2D vs T5/W5</b>	<b>W/m<sup>2</sup>K</b>	<b>2D* vs T5/W5</b>	<b>W/m<sup>2</sup>K</b>	<b>3D vs 2-D</b>
Frame_sill	1.93	1.86	-3.59%	1.87	-3.11%	1.87	0.74%
Frame_head	1.93	1.86	-3.55%	1.87	-3.18%	1.87	0.65%
Frame_jamb	2.15	2.06	-4.33%	2.00	-7.44%	2.06	0.20%
Center of glass	1.73	1.75	0.88%	1.75	0.80%	1.75	0.16%
Edge_sill	1.91	1.93	1.03%	1.93	0.78%	1.96	1.29%
Edge_head	1.91	1.93	1.07%	1.93	0.76%	1.96	1.23%
Edge_jamb	1.93	1.94	0.61%	1.94	0.40%	1.96	0.78%
<b>TOTAL</b>	<b>1.89</b>	<b>1.87</b>	<b>-0.01</b>	<b>1.86</b>	<b>-1.38%</b>	<b>1.88</b>	<b>0.41%</b>
<b>Dbi Low-e SC</b>							
<b>Spacer keff = 0.050</b>		<b>W/mK</b>					
<b>Section</b>	<b>T5/W5</b>	<b>2-D</b>	<b>% diff</b>	<b>2-D*</b>	<b>% diff</b>	<b>3-D</b>	<b>% diff</b>
	<b>W/m<sup>2</sup>K</b>	<b>W/m<sup>2</sup>K</b>	<b>2D vs T5/W5</b>	<b>W/m<sup>2</sup>K</b>	<b>2D* vs T5/W5</b>	<b>W/m<sup>2</sup>K</b>	<b>3D vs 2-D</b>
Frame_sill	1.88	1.81	-3.86%	1.82	-3.29%	1.84	1.16%
Frame_head	1.88	1.81	-3.80%	1.82	-3.36%	1.83	1.07%
Frame_jamb	2.10	2.01	-4.57%	1.95	-7.66%	2.02	0.47%
Center of glass	1.47	1.46	-0.47%	1.46	-0.57%	1.47	0.28%
Edge_sill	1.69	1.69	-0.04%	1.69	-0.44%	1.72	1.77%
Edge_head	1.69	1.69	0.02%	1.69	-0.46%	1.72	1.70%
Edge_jamb	1.72	1.71	-0.44%	1.70	-0.79%	1.72	0.99%
<b>TOTAL</b>	<b>1.70</b>	<b>1.67</b>	<b>-0.02</b>	<b>1.66</b>	<b>-2.48%</b>	<b>1.68</b>	<b>0.65%</b>

**Table 6.5-53: PVC Window – Small Size, Medium Conducting Spacer (Conduction Model)**

<b>Dbf Clear</b>		<b>Spacer keff = 0.674</b>		<b>W/mK</b>			
<b>Section</b>	<b>T5/W5</b>	<b>2-D</b>	<b>% diff</b>	<b>2-D*</b>	<b>% diff</b>	<b>3-D</b>	<b>% diff</b>
	<b>W/m<sup>2</sup>K</b>	<b>W/m<sup>2</sup>K</b>	<b>2D vs T5/W5</b>	<b>W/m<sup>2</sup>K</b>	<b>2D* vs T5/W5</b>	<b>W/m<sup>2</sup>K</b>	<b>3D vs 2-D</b>
Frame_sill	2.50	2.41	-3.72%	2.43	-2.92%	2.38	-1.42%
Frame_head	2.50	2.41	-3.74%	2.43	-2.99%	2.38	-1.45%
Frame_jamb	2.71	2.61	-3.74%	2.56	-6.10%	2.59	-0.91%
Center of glass	2.80	2.80	0.04%	2.79	-0.04%	2.80	0.06%
Edge_sill	3.05	3.06	0.38%	3.05	0.21%	3.08	0.83%
Edge_head	3.05	3.06	0.34%	3.05	0.21%	3.08	0.85%
Edge_jamb	3.04	3.05	0.30%	3.05	0.11%	3.07	0.57%
<b>TOTAL</b>	<b>2.81</b>	<b>2.79</b>	<b>-0.01</b>	<b>2.77</b>	<b>-1.31%</b>	<b>2.78</b>	<b>-0.13%</b>
<b>Dbf Low-e HC</b>		<b>Spacer keff = 0.674</b>		<b>W/mK</b>			
<b>Section</b>	<b>T5/W5</b>	<b>2-D</b>	<b>% diff</b>	<b>2-D*</b>	<b>% diff</b>	<b>3-D</b>	<b>% diff</b>
	<b>W/m<sup>2</sup>K</b>	<b>W/m<sup>2</sup>K</b>	<b>2D vs T5/W5</b>	<b>W/m<sup>2</sup>K</b>	<b>2D* vs T5/W5</b>	<b>W/m<sup>2</sup>K</b>	<b>3D vs 2-D</b>
Frame_sill	2.40	2.32	-3.54%	2.34	-2.66%	2.30	-0.77%
Frame_head	2.40	2.32	-3.53%	2.33	-2.73%	2.30	-0.83%
Frame_jamb	2.61	2.51	-3.78%	2.46	-6.08%	2.50	-0.44%
Center of glass	1.73	1.75	1.08%	1.75	1.00%	1.76	0.49%
Edge_sill	2.23	2.25	0.91%	2.24	0.40%	2.30	2.16%
Edge_head	2.23	2.25	0.95%	2.24	0.39%	2.30	2.11%
Edge_jamb	2.23	2.24	0.69%	2.23	0.21%	2.27	1.26%
<b>TOTAL</b>	<b>2.11</b>	<b>2.09</b>	<b>-0.01</b>	<b>2.08</b>	<b>-1.25%</b>	<b>2.10</b>	<b>0.38%</b>
<b>Dbf Low-e SC</b>		<b>Spacer keff = 0.674</b>		<b>W/mK</b>			
<b>Section</b>	<b>T5/W5</b>	<b>2-D</b>	<b>% diff</b>	<b>2-D*</b>	<b>% diff</b>	<b>3-D</b>	<b>% diff</b>
	<b>W/m<sup>2</sup>K</b>	<b>W/m<sup>2</sup>K</b>	<b>2D vs T5/W5</b>	<b>W/m<sup>2</sup>K</b>	<b>2D* vs T5/W5</b>	<b>W/m<sup>2</sup>K</b>	<b>3D vs 2-D</b>
Frame_sill	2.37	2.29	-3.65%	2.31	-2.71%	2.28	-0.55%
Frame_head	2.37	2.29	-3.64%	2.31	-2.79%	2.28	-0.61%
Frame_jamb	2.58	2.48	-3.92%	2.43	-6.18%	2.48	-0.29%
Center of glass	1.47	1.47	-0.20%	1.46	-0.27%	1.48	0.76%
Edge_sill	2.03	2.03	0.18%	2.02	-0.44%	2.09	2.78%
Edge_head	2.03	2.03	0.18%	2.02	-0.45%	2.09	2.76%
Edge_jamb	2.03	2.03	-0.15%	2.02	-0.68%	2.06	1.64%
<b>TOTAL</b>	<b>1.94</b>	<b>1.91</b>	<b>-0.02</b>	<b>1.90</b>	<b>-2.10%</b>	<b>1.92</b>	<b>0.64%</b>

**Table 6.5-54: PVC Window – Small Size, Highly Conducting Spacer (Conduction Model)**

<b>Dbf Clear</b>		<b>Spacer keff = 1.900</b>		<b>W/mK</b>			
<b>Section</b>	<b>T5/W5</b>	<b>2-D</b>	<b>% diff</b>	<b>2-D*</b>	<b>% diff</b>	<b>3-D</b>	<b>% diff</b>
	<b>W/m<sup>2</sup>K</b>	<b>W/m<sup>2</sup>K</b>	<b>2D vs T5/W5</b>	<b>W/m<sup>2</sup>K</b>	<b>2D* vs T5/W5</b>	<b>W/m<sup>2</sup>K</b>	<b>3D vs 2-D</b>
Frame_sill	2.66	2.56	-3.87%	2.59	-2.79%	2.52	-1.63%
Frame_head	2.66	2.56	-3.84%	2.59	-2.84%	2.52	-1.68%
Frame_jamb	2.88	2.77	-4.10%	2.71	-6.14%	2.74	-0.97%
Center of glass	2.80	2.80	0.07%	2.80	-0.03%	2.80	0.10%
Edge_sill	3.15	3.15	0.00%	3.14	-0.36%	3.17	0.73%
Edge_head	3.15	3.15	0.05%	3.14	-0.31%	3.18	0.88%
Edge_jamb	3.14	3.14	0.00%	3.13	-0.33%	3.16	0.53%
<b>TOTAL</b>	<b>2.89</b>	<b>2.86</b>	<b>-0.01</b>	<b>2.85</b>	<b>-1.47%</b>	<b>2.85</b>	<b>-0.15%</b>

<b>Dbf Low-e HC</b>		<b>Spacer keff = 1.900</b>		<b>W/mK</b>			
<b>Section</b>	<b>T5/W5</b>	<b>2-D</b>	<b>% diff</b>	<b>2-D*</b>	<b>% diff</b>	<b>3-D</b>	<b>% diff</b>
	<b>W/m<sup>2</sup>K</b>	<b>W/m<sup>2</sup>K</b>	<b>2D vs T5/W5</b>	<b>W/m<sup>2</sup>K</b>	<b>2D* vs T5/W5</b>	<b>W/m<sup>2</sup>K</b>	<b>3D vs 2-D</b>
Frame_sill	2.58	2.48	-3.84%	2.51	-2.71%	2.46	-1.16%
Frame_head	2.58	2.48	-3.86%	2.51	-2.75%	2.46	-1.16%
Frame_jamb	2.80	2.69	-4.26%	2.64	-6.15%	2.67	-0.53%
Center of glass	1.73	1.75	1.16%	1.75	1.08%	1.76	0.63%
Edge_sill	2.36	2.37	0.20%	2.36	-0.19%	2.43	2.64%
Edge_head	2.36	2.37	0.26%	2.36	-0.19%	2.43	2.57%
Edge_jamb	2.36	2.36	0.05%	2.35	-0.34%	2.40	1.58%
<b>TOTAL</b>	<b>2.20</b>	<b>2.18</b>	<b>-0.01</b>	<b>2.17</b>	<b>-1.48%</b>	<b>2.19</b>	<b>0.47%</b>

<b>Dbf Low-e SC</b>		<b>Spacer keff = 1.900</b>		<b>W/mK</b>			
<b>Section</b>	<b>T5/W5</b>	<b>2-D</b>	<b>% diff</b>	<b>2-D*</b>	<b>% diff</b>	<b>3-D</b>	<b>% diff</b>
	<b>W/m<sup>2</sup>K</b>	<b>W/m<sup>2</sup>K</b>	<b>2D vs T5/W5</b>	<b>W/m<sup>2</sup>K</b>	<b>2D* vs T5/W5</b>	<b>W/m<sup>2</sup>K</b>	<b>3D vs 2-D</b>
Frame_sill	2.56	2.46	-3.96%	2.49	-2.76%	2.44	-0.96%
Frame_head	2.56	2.46	-3.98%	2.49	-2.82%	2.44	-0.99%
Frame_jamb	2.78	2.66	-4.40%	2.62	-6.26%	2.65	-0.41%
Center of glass	1.47	1.47	-0.09%	1.47	-0.17%	1.48	0.93%
Edge_sill	2.18	2.16	-0.67%	2.15	-1.25%	2.23	3.15%
Edge_head	2.17	2.16	-0.60%	2.15	-1.22%	2.23	3.12%
Edge_jamb	2.17	2.15	-0.83%	2.14	-1.34%	2.19	1.87%
<b>TOTAL</b>	<b>2.03</b>	<b>2.00</b>	<b>-0.02</b>	<b>1.99</b>	<b>-2.36%</b>	<b>2.01</b>	<b>0.68%</b>

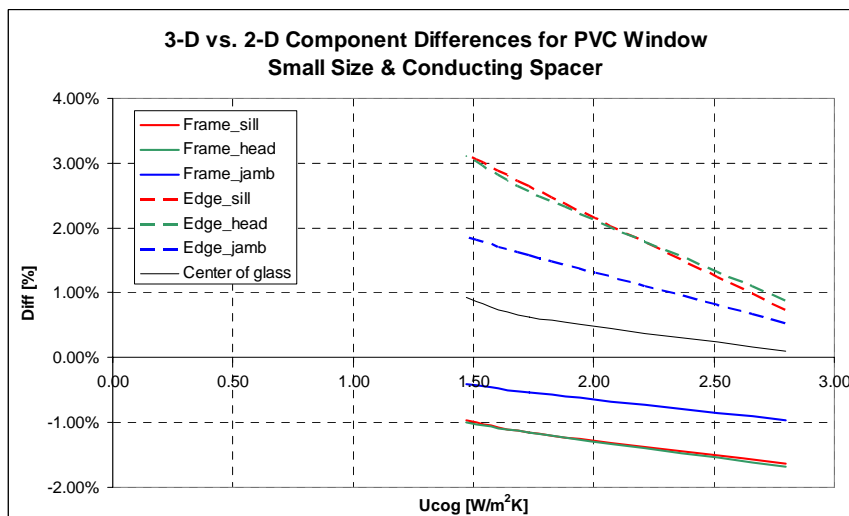
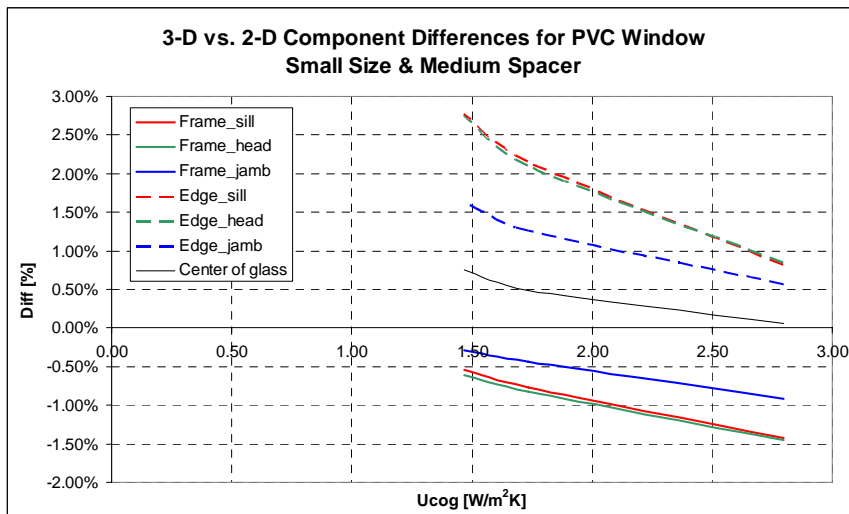
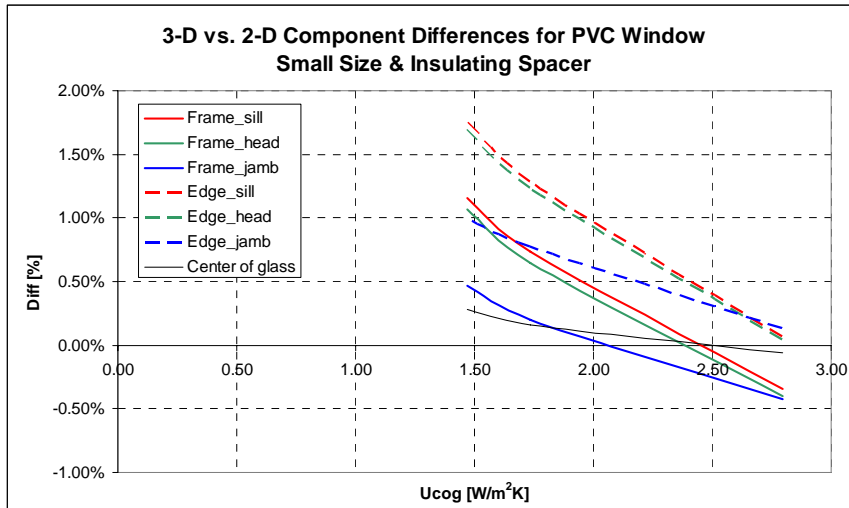

**Figure 6.5-18: Component Level Difference Graphs for Small Size PVC Window (Conduction Model)**

## 6.6 Result comparison for conduction and convection models: -

Results from Conduction and convection models were compared to find out the differences between them. Conduction model results were obtained from Therm/Window and FLUENT 2-d and 3-D models. Convection model results were obtained from FLUENT 2-D and 3-D models. Figure 6.6-1 and Figure 6.6-2 show the Temperature contour on Sill and head cross-sections for the 2-D FLEUNT convection and conduction models.

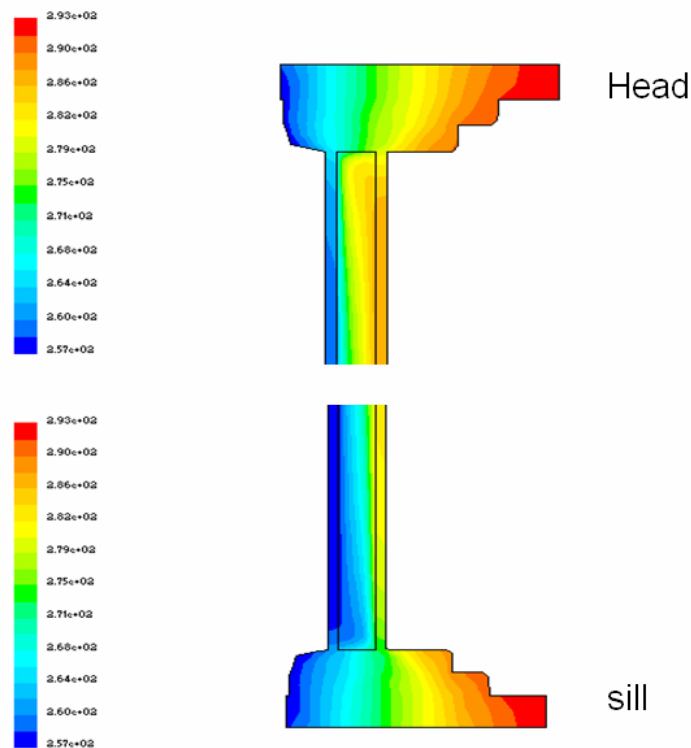

**Figure 6.6-1: Temperature contour for sill and head cross-sections-Convection model**

(FLUENT 2-D, Wood window)

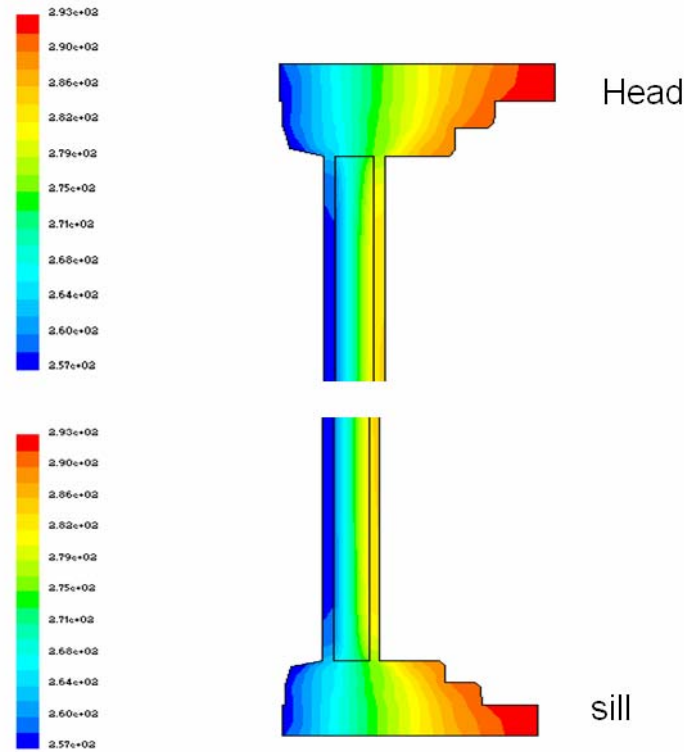

**Figure 6.6-2: Temperature contour for sill and head cross-sections-Conduction model (FLUENT 2-D, Wood window)**

Figure 6.6-3 plots the inside (warm side) surface temperatures along the height of window. Conduction and convection model results differ significantly on local level but overall heat transfer results are very close. Convection model heat transfer is more through the sill portion of the windows compared to head portion. In conduction, model heat flow is almost symmetric about horizontal plane and almost same in sill and head portion. It could be explained from the temperature profile (Figure 6.6-3). In conduction models, temperature is constant in the CoG region due to 1-D nature of the heat transfer while in the convection model 2-d heat transfer shows.



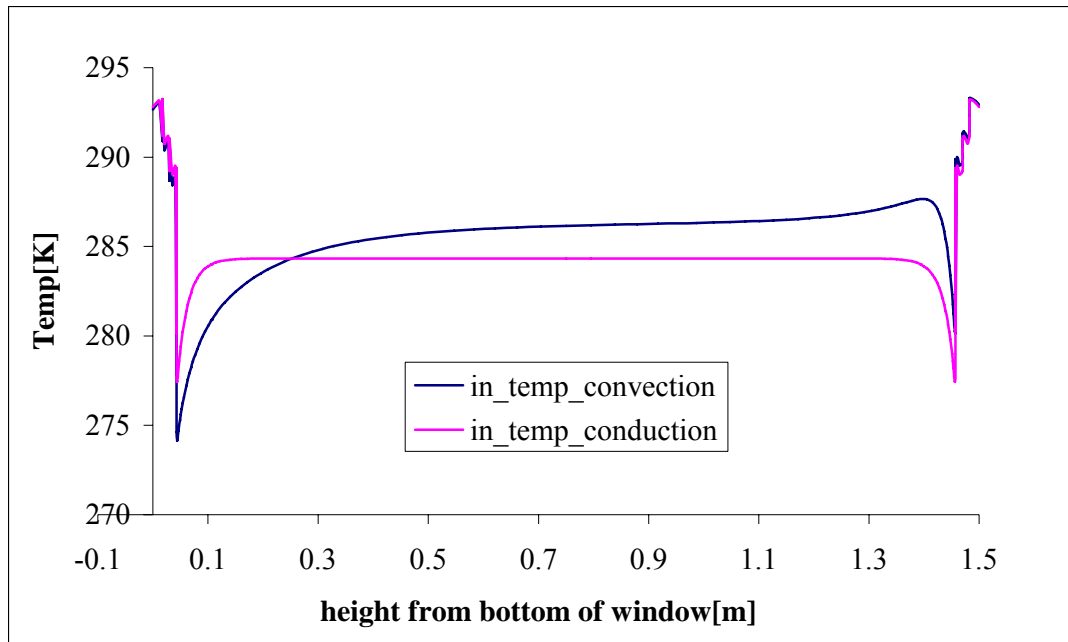

**Figure 6.6-3: Temperature plot on inside surface for conduction and convection model**

## 6.7 Observations and Discussion: -

One of the most striking results of this study is the validity of the assumption in 2-D models that 3-D conduction heat transfer corner effects are relatively small for present day frame and glazing materials. Close inspection of Tables and Figures in this chapter, reveals that for highly conducting frames, the difference is literally hovering around 0% for the whole product U-factor. For more insulating frames, like Wood and PVC, this difference becomes larger for super insulating glazing systems (i.e., R10), while it is still fairly small for standard glazing systems, including present day good insulating glazing (i.e., Argon, SC Low-e), for which the difference is hovering around 0.5% for the whole product U-factor. For R-10 glazing, the difference for wood and PVC frames exceeds 2% for smaller frames. This is still relatively small difference but for very small windows

may become important and may need to be included in THERM and WINDOW as a correction.

As the window size increase, the projected frame area in relation to the glazing area decreases and hence the 3-D effects reduced further for larger size windows. Another interesting observation is that spacer conductivity did not play significant role in the level of differences between 3-D and 2-D conduction heat transfer models. The most significant factors were level of glazing insulation, frame conductance and to some extent, size.

In order to understand differences on the whole product level, each of the windows were subdivided into the individual regions and their differences were investigated separately. These detailed results are presented in Appendices A to J.

Based on detailed analysis of these individual component results, an overall conclusion can be drawn that small differences between 2-D and 3-D conduction heat transfer results are due to somewhat canceling effect of the summation of individual components effects. The most common canceling effect exists between frame cross-sections and jamb cross-sections. They are usually at the opposite side of y-axis. Individual component U-factor differences were quite significant for some of the components going up to 10% for some window designs.

As expected, sill and head heat-transfer effects were very similar due to their symmetric location with respect to jamb cross-section, while jamb had different results, depending on the size and type of window. Jamb had the same design as head and sill in all of the models, which was another attempt to limit variables in this study. The difference is due only to the position within the window, not because of the arbitrary

differences in individual geometries. On the other hand, this is also a limiting factor because most slider and projecting windows would have different sill and head designs.

Center of glass differences go up to around 4% very consistently for smaller size windows, which is somewhat expected result, indicating that for smaller windows, center of glass area, includes some 2-D and 3-D effects.

For both, conduction and convection, models 3-D effects were relative small, but when compared to each other there are significant differences in the results of these two models. This is in part due to the selection of viscous model. However, the head and sill heat transfer results and their temperature profiles are much different. Conduction model represents the average of the sill and head temperature points and heat transfer result. In reality, the heat transfer takes place closer to the convection model, which presents day 2-D heat transfer analysis tools do not take into account. Although, for condensation resistance purpose, convection model is used in THERM, it would be very helpful to have convection modeling capability on simplified 2-D tools e.g. THERM/WINDOW.

## CHAPTER 7

### CONCLUSIONS AND RECOMMENDATIONS

This study is the first of its kind of looking in 3-D corner heat transfer effects in fenestration systems in a systematic way. Four different frame materials, covering practically entire range of present day frame materials, were considered, three spacer types, covering the entire range of present day and future spacer materials and designs, and four different glazing systems, covering the entire range of present day and future glazing designs, except for single glazing, were investigated and reported in this study.

The first conclusion from this study is that for present day frame, spacer and glazing materials, 3-D corner conduction heat transfer effects are fairly small and can be ignored in existing fenestration computer modeling tools.

Spacer conductivity does not play significant role in the level of differences between 3-D and 2-D conduction heat transfer models. Hence, frame and IGU performances dictate the extent of 3-D effects.

For frames and glazing with higher thermal resistance, the difference between 2-D and 3-D heat transfer effects becomes more pronounced and significant and it exceeds 2% for smaller size windows. As the market demand shifts towards higher performance fenestration products, 3-D effects would have to be taken into account.

Smaller size windows, with higher frame to glass area ratio, had more 3-D effects compared to larger size windows with smaller frame to glass area ratio.

On an individual component level, there were of higher magnitude, going up to 10%. These differences, would however often cancel each other as the frame and edge of

glass sections would usually have different sign in front of the difference. These differences are quite large which are not visible from the overall results. Correct local information at component level would help in accurate determination of local temperature, condensation resistance, and local heat flux.

Although convection and conduction models shows similar overall 3-D effects, the local results of these models were much different. It is recommended to implement a convection model for 2-D analysis to correctly obtain temperature and heat transfer result.

In the present study, inside and outside surface boundary conditions were determined through the THERM/Window5 e.g NFRC standard boundary condition. Future work should incorporate dynamic local boundary conditions to expose the 3-Deffects caused due to localized heat transfer effects.

Future windows will be more insulating than present day ones, approaching the performance of R-10 glazing and more insulating frames, and based on this work, for these windows the differences are more pronounced and may require correlations to be applied to 2-D models, or may necessitate the development of dedicated 3-D fenestration heat transfer computer programs.

## APPENDIX A

### Mesh details

Appendix A1: Meshing parameters of the glazing cavity dimensions

Window size	Mesh Grading parameter	Width (x-axis)	Height (y-axis)	Depth (z-axis)
0.6m x 1.50m	Interval Count	10	100	12
0.6m x 1.20m	Interval Count	10	90	12
0.6m x 0.91m	Interval Count	10	80	12

Appendix A2: Grid information for 3-d window mesh

	0.6m x 1.50m	0.6m x 1.20m	0.6m x 0.91m
Number of nodes	39761	37431	35791
Number of cells	32442	30582	29192
Number of faces	104839	98249	94349

## APPENDIX B

### Result Image Samples

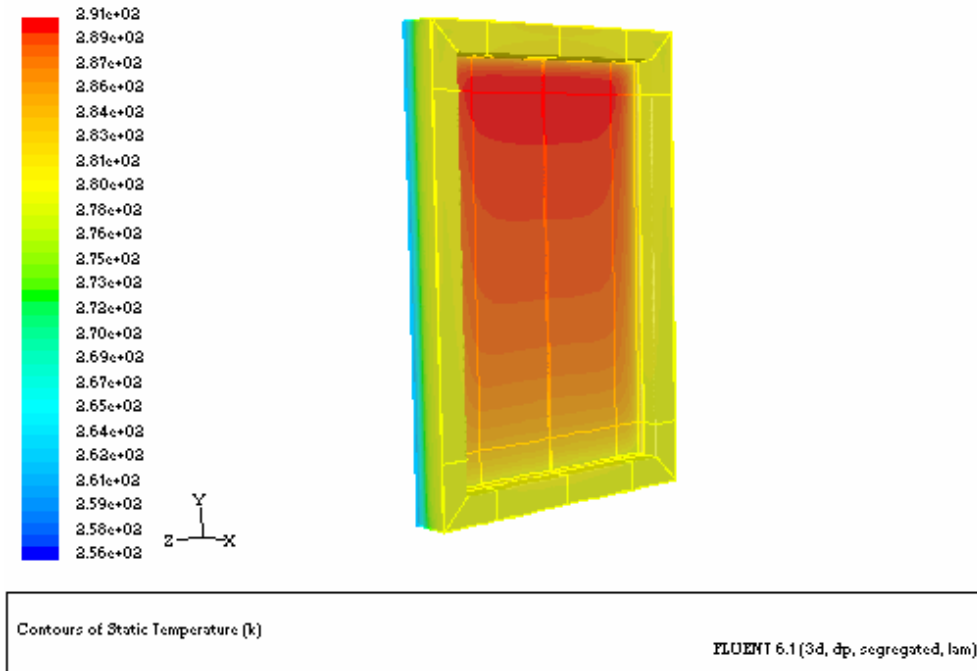

**Figure B1: Temperature contour on the inside surface of aluminum window- (CONVECTION MODEL)**

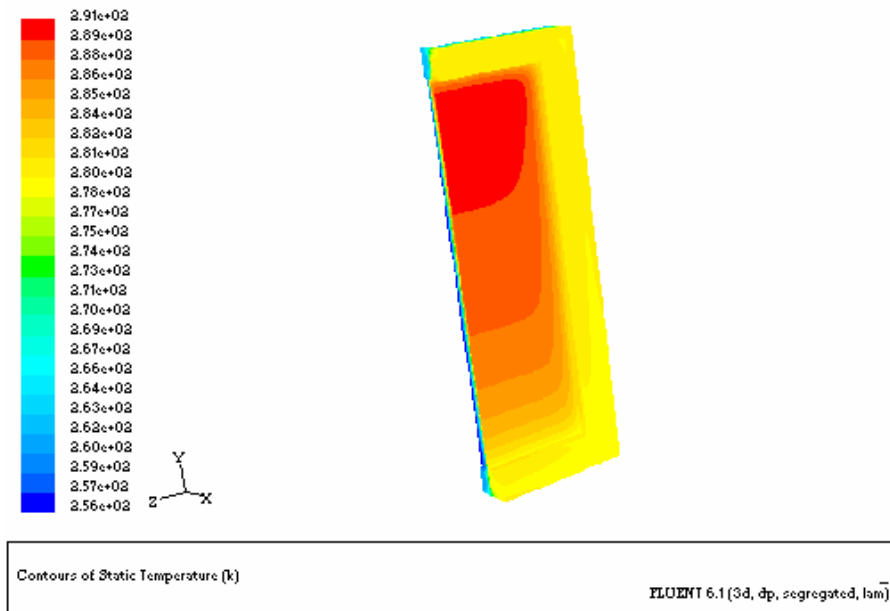

**Figure B2: Temperature contour on the inside surface of aluminum window- (CONVECTION MODEL)**

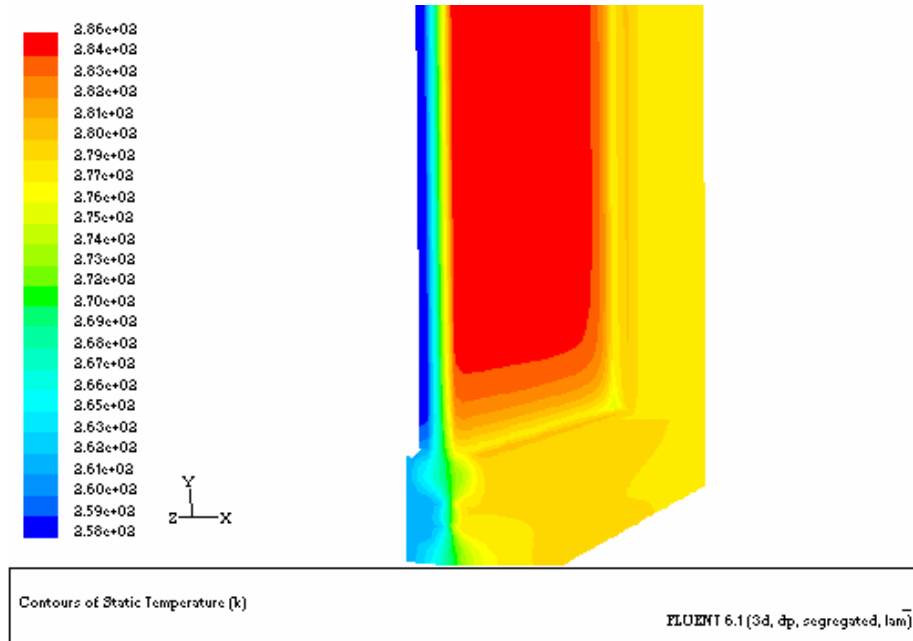

**Figure B3: Temperature contour on the inside surface of aluminum window- (CONDUCTION MODEL)**

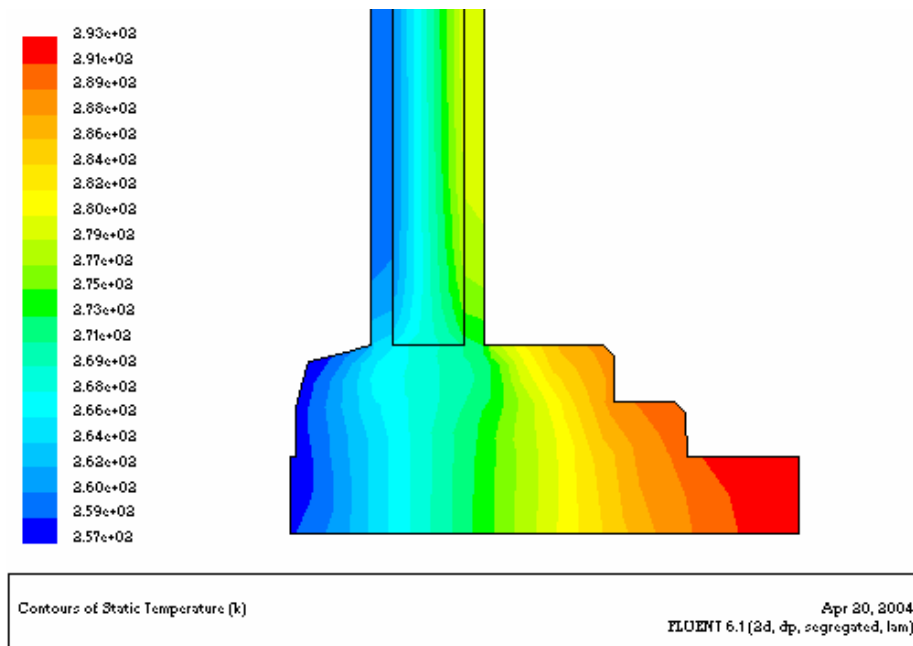

**Figure B4: Temperature contour in the sill section-Conduction model -2-d**



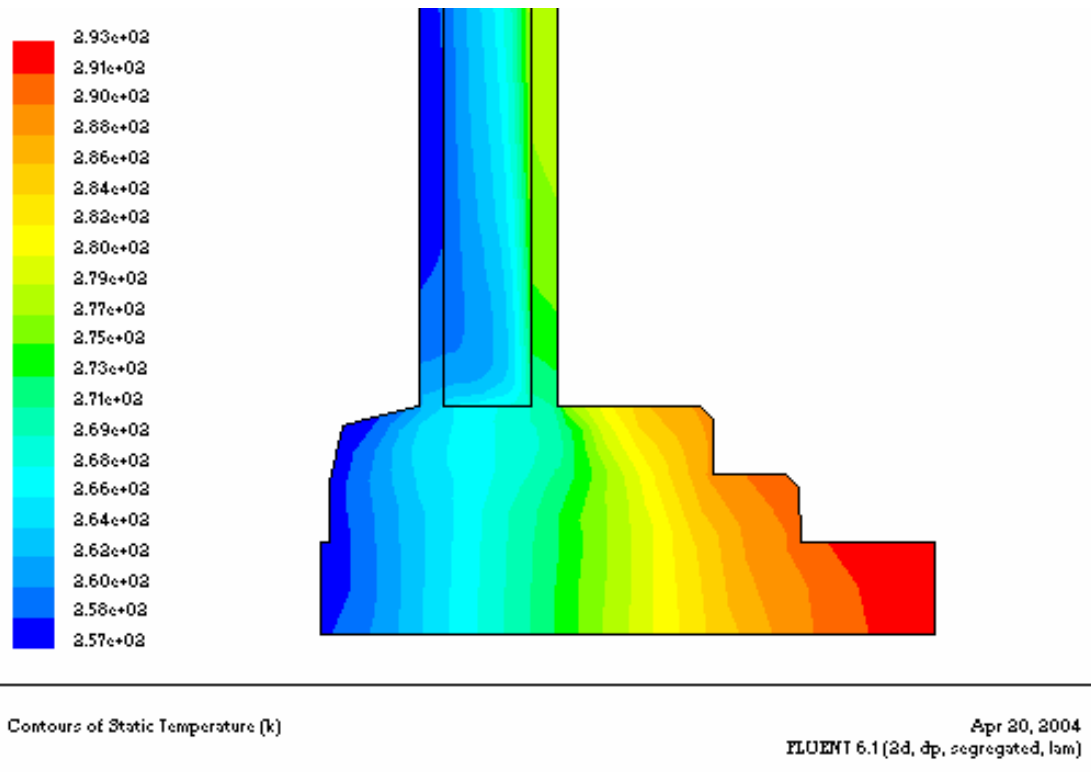

Figure B5: Temperature contour in the sill section-Convection model 2-d

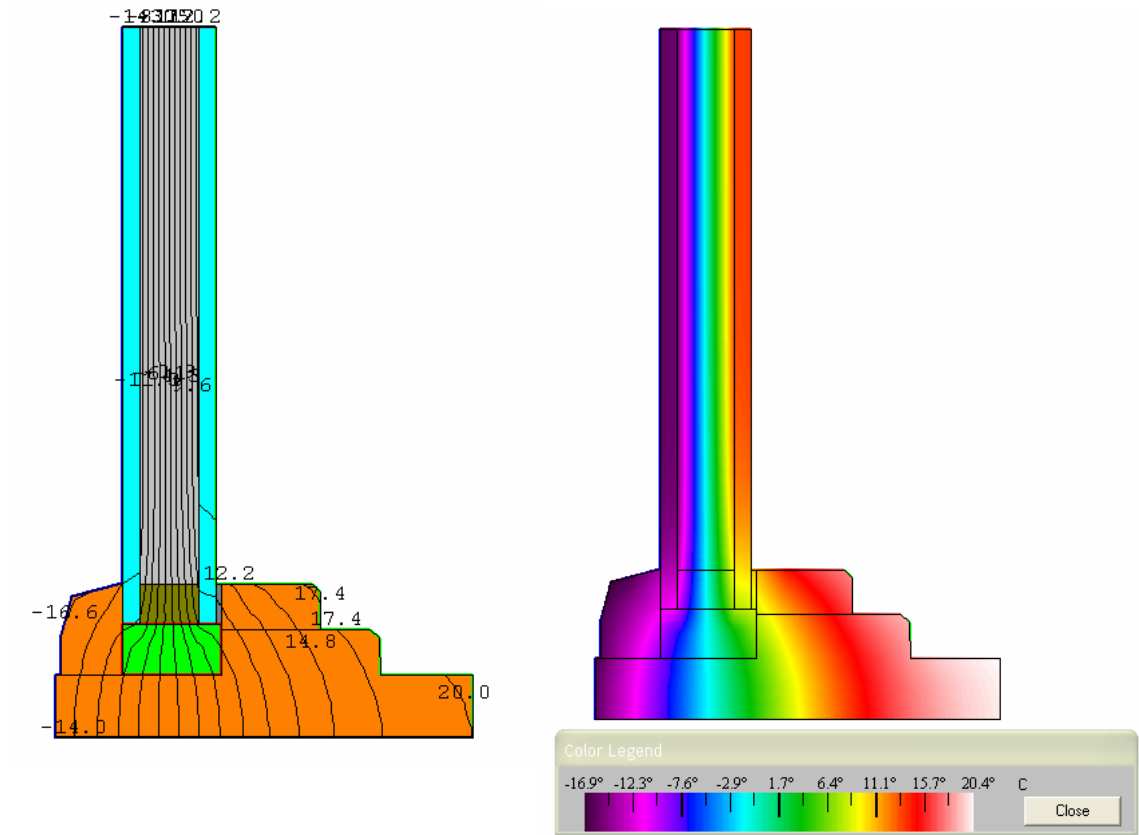

Figure B6: Temperature contour in the sill section of Wood Window -THERM model -2-d

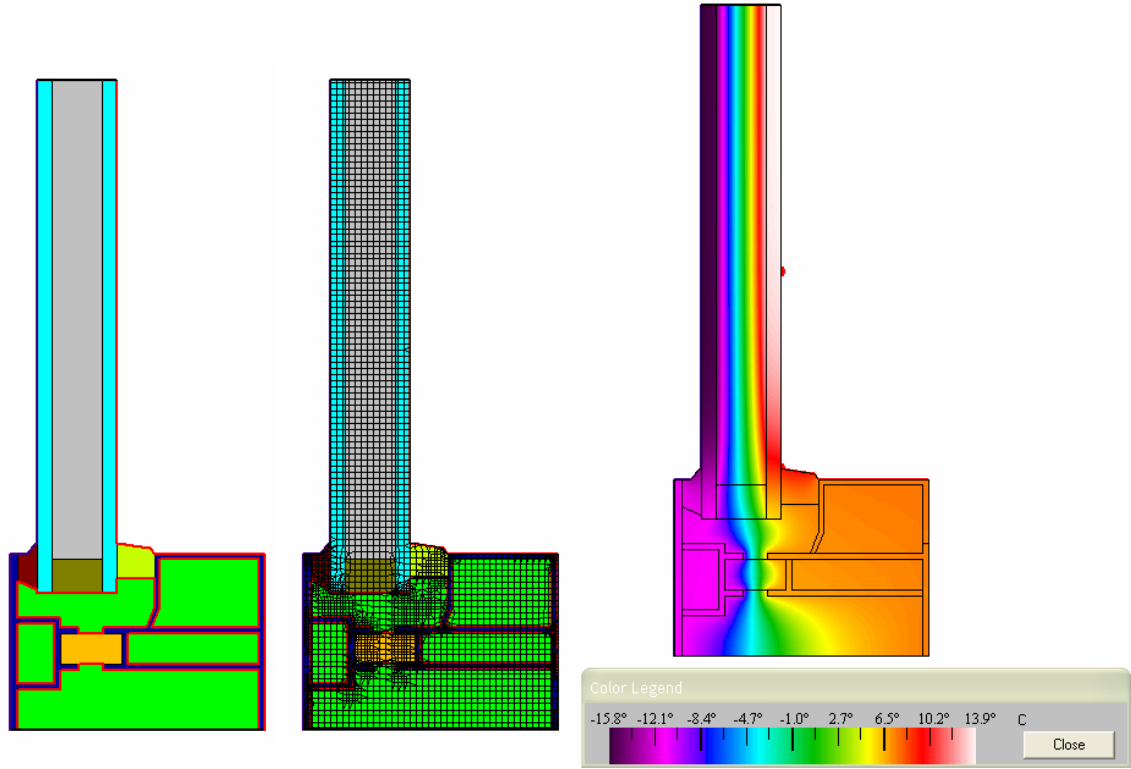

Figure B7: Temperature contour in the sill section of T/B AL window -THERM model -2-d

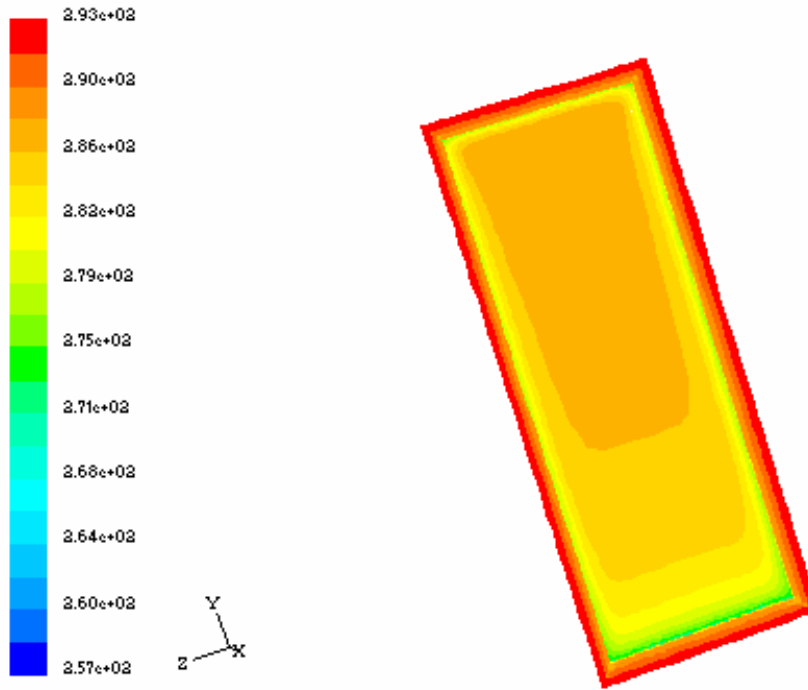

Figure B8: Temperature contour on the inside surface of T/B AL window - Convection model -3-d

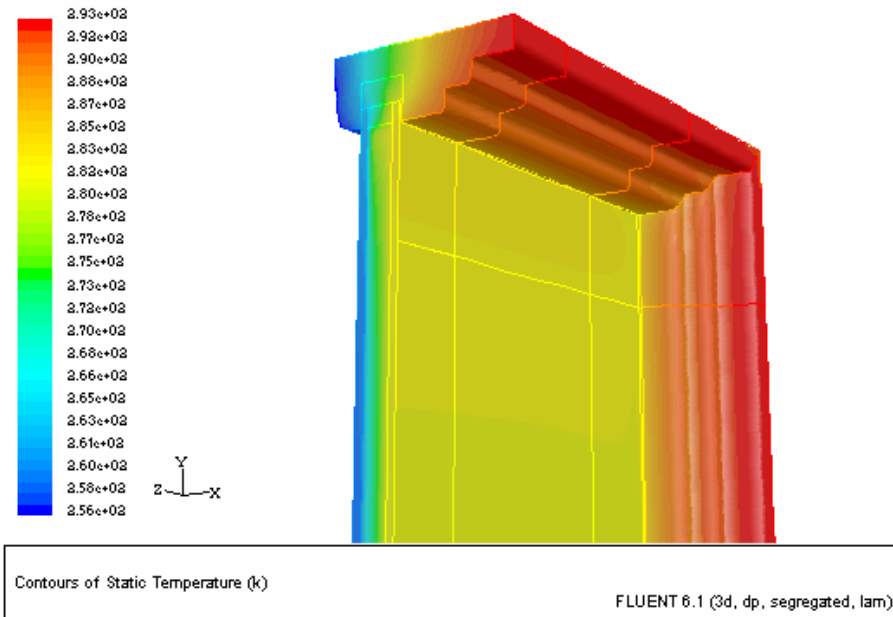
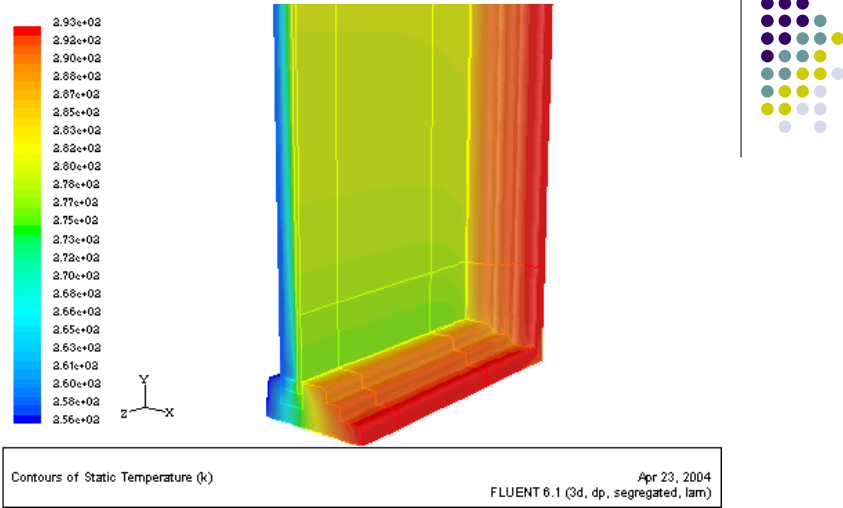

Figure B8: Temperature contour on the inside surface of Wood window - Convection model -3-d



TEMPERATURE contour on the inside surface of wood window- CONVECTION MODEL

93

Figure B8: Temperature contour on the inside surface of Wood window - Convection model -3-d

## BIBLIOGRAPHY

ASHRAE Standard 142P 2000. Standard Method for Determining and Expressing the Heat Transfer and Total Optical Properties of Fenestration Products, American Society of Heating Refrigerating and Air-Conditioning Engineers.

Carpenter, Stephen C., McGowan, Alex, 1998. Three-Dimensional Heat Transfer Effects in Building Components.

Curcija, D. C. and Goss, W. P., 1993, "Two-dimensional Natural Convection Over The Isothermal Indoor Fenestration Surface - Finite Element Numerical Solution," ASHRAE Transactions 99(1).

Curcija, D. C. and Goss, W. P., 1994, "Two-dimensional Finite Element Model of Heat Transfer in Complete Fenestration Systems," ASHRAE Transactions 100(2).

Curcija, D., 1992. Three-Dimensional Finite Element Model of Overall, Night Time Heat Transfer Through Fenestration Systems, Ph.D. Dissertation, Department of Mechanical Engineering, University of Massachusetts.

Dariush Arasteh, Elizabeth Finlayson, Joe Huang, Charlie Huizenga, Robin Mitchell, and Mike Rubin, "State-of-the-Art Software for Window Energy-Efficiency Rating and Labeling", Building Technologies Department Environmental Energy Technologies Division Ernest Orlando Lawrence Berkeley National Laboratory University of California 1 Cyclotron Road Berkeley, CA

Elsherbiny, S.M., Raithby, G. D., and Hollands, K. G. T., 1982, "Heat Transfer by Natural Convection across Vertical and Incline Air Layers," Transactions of the ASME, Vol. 104, pp. 96-102.

FDI 2000. Fluid Dynamics International, Fluid Dynamics Analysis Package Revision 8.52, Evanston, IL.

FLUENT 6.2, 2001, FLUENT Inc, Fluid Dynamics International, Fluid Dynamics Analysis Package.

Fisher, S., 1994. Private communications, Marvin Windows and Doors, Warroad, MN.

Frederick, Ramon L., "On the aspect ratio for which the heat transfer in differentially heated cavities is maximum", International Communications in Heat and Mass Transfer v 26 n 4 1999 Elsevier Science Ltd Exeter Engl p 549-558 0735-1933 IHMTDL

Fusegi, T.; Hyun, J.M.; Kuwahara, K., "Three-dimensional natural convection in a cubical enclosure with walls of finite conductance", Natural/Forced Convection and Combustion Simulation Second International Conference on Advanced Computational

Methods in Heat Transfer Jul 1992 1992 Publ by Computational Mechanics Inc Billerica MA

GAMBIT 1998. FLUENT Inc. Fluid Dynamics Analysis Package Revision 8.52, Evanston, IL.

J. P. Power, 1999. Three-Dimensional Finite Element Model of Turbulence Flow and Heat Transfer in a Fenestration System, Ph.D. Dissertation, Department of Mechanical Engineering, University of Massachusetts.

LBL 1994. Lawrence Berkeley Laboratory, Windows and Daylighting Group, Berkeley, CA.

LBL, 2001, "Window 5.2: A PC Program for Analyzing Window Thermal Performance," Lawrence Berkeley National Laboratory, Windows and Daylighting Group, Berkeley, CA.

LBL, 2002, "THERM 5.2: A PC Program for Analyzing Two-dimensional Heat Transfer through Building Products," Lawrence Berkeley National Laboratory, Windows and Daylighting Group, Berkeley, CA

Lock, G.S.H.; Han, J.-C., "Effects of tilt, skew and roll on natural convection in a slender, laterally-heated cavity", Mathematical and Computer Modelling (Oxford) v 13 n 2 1990 p 23-32 0895-7177 MCMOEG

Mallinson, G. D., De Vhal Davis, G., "Three-Dimensional Natural Convection In a Box: A Numerical Study", Jfm., 1977

NFRC 1997. NFRC100: Procedures for determining Fenestration Product U-factors. National Fenestration Rating Council.

Peutrec, Y.Le.; Lauriat, G., "Effects of the heat transfer at the side walls on natural convection in cavities", Journal of Heat Transfer, Transactions ASME v 112 n 2 May 1990 p 370-378 0022-1481 JHTRAO.

Power, J.P., 1999, "Finite Element Model of Turbulent Flow and Heat Transfer in a Fenestration System," Ph.D. Thesis, Department of Mechanical Engineering, University of Massachusetts Amherst

Reddy, J. N., "Finite-Element Simulation of Natural Convection in Three-Dimensional Enclosures"; A.S.M.E. Paper. 82-HT-71, A.S.M.E. Winter Annual Meeting, Phoenix, AZ.

Shapiro, M. M., El Diasty, R., Fazio, P., "Transient Three-dimensional Window Thermal Effects", Energy and Buildings, 1987

Williams, P.T.; Baker, A.J.; Kelso, R.M., "Numerical calculation of room air motion - part 2: the continuity constraint finite element method for three-dimensional incompressible thermal flows", ASHRAE Transactions Proceedings of the ASHRAE Winter Meeting Jan 23-26 1994 v100 n1 1994 New Orleans, LA, , USA, ASHRAE Atlanta GA

White, F.M., 1988, "Heat and Mass Transfer", Addison-Wesley Publishing Company.

Wilcox, D.C., 1993, "Turbulence Modeling for CFD," Griffin Printing.

Wright, J.L., 1990, "The Measurement and Computer Simulation of Heat Transfer in Glazing Systems," Ph.D. dissertation, Department of Mechanical Engineering, University of Waterloo.

Enermodal Engineering Ltd. 1991. "FRAME<sup>TM</sup> – A Computer Program to Evaluate the Thermal Performance of Eindow Frame Systems, Version 3.0." Waterloo, Ontario, Canada.

Zhao, Y., 1997, "Investigation of Heat Transfer Performance in Fenestration System Based on Finite Element Methods," Ph.D. Thesis, Department of Mechanical and Industrial Engineering, University of Massachusetts Amherst.

Zhao, Y., Curcija, D., and Goss, W.P., 1999, "Convective Heat Transfer Correlations for Fenestration Glazing Cavities: A Review," ASHRAE Transactions, Vol. 105, Part 2.